



INTERNATIONAL ATOMIC ENERGY AGENCY



XA0054311

Liquid Penetrant and Magnetic Particle Testing at Level 2

Manual for the Syllabi
Contained in IAEA-TECDOC-628,
“Training Guidelines in
Non-destructive Testing Techniques”

31-16 R

Liquid Penetrant and Magnetic Particle Testing at Level 2

Manual for the Syllabi
Contained in IAEA-TECDOC-628,
“Training Guidelines in
Non-destructive Testing Techniques”

The originating Section of this publication in the IAEA was:

Industrial Applications and Chemistry Section
International Atomic Energy Agency
Wagramer Strasse 5
P.O. Box 100
A-1400 Vienna, Austria

LIQUID PENETRANT AND MAGNETIC PARTICLE TESTING AT LEVEL 2
IAEA, VIENNA, 2000
IAEA-TCS-11

© IAEA, 2000

Printed by the IAEA in Austria
February 2000

FOREWORD

The International Atomic Energy Agency (IAEA) has been active in the promotion of non-destructive testing (NDT) technology in the world for many decades. The prime reason for this interest has been the need for stringent standards for quality control for safe operation of industrial as well a nuclear installations. It has successfully executed a number of programmes and regional projects of which NDT was an important part. Through these programmes a large number of persons have been trained in the member states and a state of self sufficiency in this area of technology has been achieved in many of them.

All along there has been a realization of the need to have well established training guidelines and related books in order, firstly, to guide the IAEA experts who were involved in this training programme and, secondly, to achieve some level of international uniformity and harmonization of training materials and consequent competence of personnel.

The syllabi for training courses have been published in the form of two TECDOC publications. The first was IAEA-TECDOC-407 which contained syllabi for the basic five methods, i.e. liquid penetrant testing, magnetic particle testing, eddy current testing, radiographic testing and ultrasonic testing, and the second and revised is IAEA-TECDOC-628 which includes additional methods of visual testing and leak testing. IAEA-TECDOC-628, as well as most of the international standards on the subject of training and certification of NDT personnel including ISO 9712, define three levels of competence, namely, Level 1, Level 2 and Level 3. Among these, Level 1 is the lowest and Level 3 the highest. The intermediate Level 2 is considered to be the most appropriate for persons who, beside other duties, are expected to independently undertake practical testing in the relevant method of NDT; develop NDT procedures adapted to various problems; prepare written instructions; make accept/reject decisions in accordance with relevant standards and specifications; be able to train and supervise the Level 1 staff under them and organize and report NDT results.

The next logical step is to compile the textbooks and training manuals in accordance with these syllabi. Work in this regard has been undertaken and the manuals on radiographic testing and ultrasonic testing have already been issued in 1992 and 1999, respectively, in the Training Course Series.

Compilation of this book is a continuation of that effort. These methods, in spite of their apparent simplicity, are the most widely used NDT methods to determine surface discontinuities, even in the most sophisticated of industries, including the nuclear and aerospace industries. The first draft of the book was put together by a group of consultants from Canada, Germany, India, Spain and Romania. It was reviewed by the National Centre for Non-destructive Testing (NCNDT) in Pakistan to bring it as close as possible to the syllabus requirements of IAEA-TECDOC-628. This has been done by putting in additional material wherever needed and then rearranging the whole in accordance with the format of Level 2 Surface Method Testing syllabi in IAEA-TECDOC-628.

The section on materials, manufacturing processes and defects, which is common to all the NDT methods, has been adapted from the previous publications in the Training Course Series on Level 2 Radiographic and Ultrasonic Testing. An extensive bibliography at the end covers all the publications which were used in the compilation as well as those which can be consulted for furthering the knowledge of testing of materials using surface methods.

The IAEA wishes to express its appreciation to all those who contributed to the production of these Training Course Notes and to the governments and organizations whose financial and technical support made this publication possible.

The IAEA officer responsible for this publication was A.A. Khan of the Division of Physical and Chemical Sciences.

EDITORIAL NOTE

The use of particular designations of countries or territories does not imply any judgement by the publisher, the IAEA, as to the legal status of such countries or territories, of their authorities and institutions or of the delimitation of their boundaries.

The mention of names of specific companies or products (whether or not indicated as registered) does not imply any intention to infringe proprietary rights, nor should it be construed as an endorsement or recommendation on the part of the IAEA.

CONTENTS

1.	GENERAL KNOWLEDGE	1
1.1.	Basic principles of non-destructive testing (NDT)	1
1.1.1.	Definition and importance of NDT	1
1.1.2.	Types of NDT methods	1
1.1.3.	Visual testing (VT).....	2
1.1.4.	Liquid penetrant testing (PT)	3
1.1.5.	Magnetic particle testing (MT)	5
1.1.6.	Eddy current testing (ET)	7
1.1.7.	Radiographic testing method (RT)	10
1.1.8.	Ultrasonic testing (UT).....	14
1.1.9.	Comparison of different NDT methods	16
1.2.	Materials and defects	16
1.2.1.	Structure of metals and alloys	16
1.2.2.	Properties of materials (metallic & non-metallic).....	23
1.2.3.	Discontinuities and defects in metallic materials.....	27
1.3.	Processing and defects.....	28
1.3.1.	Primary processes and related defects.....	28
1.3.2.	Manufacturing processes and related defects	42
1.4.	Materials in service.....	80
1.4.1.	Behaviour of materials in service.....	80
1.4.2.	Conditions leading to defects and failures	80
1.4.3.	Concepts of rupture development in metals.....	88
1.5.	Quality and standardization	88
1.5.1.	Quality.....	88
1.5.2.	Quality control.....	89
1.5.3.	Quality assurance	89
1.5.4.	Examination and testing.....	89
1.5.5.	Inspection	90
1.5.6.	Process of standardization.....	90
1.5.7.	Guides and recommended practices	90
1.5.8.	Standards	90
1.5.9.	Codes and specifications	91
1.5.10.	Procedure.....	91
1.5.11.	Protocols.....	91
1.5.12.	Report.....	91
1.5.13.	Records.....	91
1.5.14.	Development of a quality system	91
2.	PHYSICAL PRINCIPLES OF THE TEST (PT)	97
2.1.	General description of the method	97
2.2.	Properties of liquid penetrants.....	97
2.2.1.	Viscosity.....	97
2.2.2.	Surface tension	98
2.2.3.	Angle of contact between liquid and solid	99
2.2.4.	Capillarity.....	99
2.3.	Behaviour of liquid penetrants	100
2.3.1.	Wettability.....	100

2.3.2.	Penetrability	100
2.3.3.	Washability.....	101
2.3.4.	Retention and bleeding.....	101
2.3.5.	Influence of surface state of the sample, the contamination and temperature	101
2.4.	Solutions and dispersions	102
2.4.1.	Solvents	102
2.4.2.	Dispersive agents.....	102
2.4.3.	Emulsifiers	102
2.5.	Mechanism of development	103
2.5.1.	Granulometry of powders.....	103
2.5.2.	Types and phenomena of fine powder aggregation.....	103
2.5.3.	Suspension of powders in liquids.....	104
2.6.	Luminous and ultraviolet spectrum	105
2.6.1.	Colour & fluorescence	105
2.6.2.	Colours	105
2.6.3.	Absorption of light	106
2.6.4.	Beer's law	106
2.6.5.	Fluorescent pigments.....	106
2.7.	Basic formulation of penetrating liquids with oily and non oily base.....	106
2.7.1.	Additives and conditioners.....	106
2.8.	Removers used in the process.....	107
2.8.1.	Basic formulation and properties	107
2.8.2.	Emulsifiers	107
2.8.3.	Lipophilic and hydrophilic agents	107
3.	PROCESSING (PT).....	109
3.1.	Reparation of the work-pieces, treatment, identification and protection of the areas not to be examined.....	109
3.1.1.	Treatment	109
3.1.2.	Identification	109
3.2.	Cleaning prior to inspection	110
3.2.1.	Various techniques applicable.....	110
3.2.2.	Conditions and limitations of the different cleaning techniques	111
3.2.3.	Comparison of the effectiveness of the different techniques in relation to the surface state of the specimen	112
3.3.	Conditions and requirements for the different drying stages.....	112
3.3.1.	Use of cold and hot air	112
3.3.2.	Temperature and time.....	112
3.4.	Inspection process.....	113
3.4.1.	Application of penetrating agent	113
3.4.2.	Removal of excess penetrating agent.....	116
3.4.3.	Conditions for the application of lipophilic and hydrophilic emulsifiers.....	119
3.4.4.	Application of the developer.....	119
3.5.	Observation of indications.....	122
3.5.1.	Lighting conditions for coloured liquids and UV radiation for fluorescent liquids.....	122

3.5.2.	Sequence and time of observation.....	122
3.5.3.	Interpretation of the findings and identification of the type of defects	122
3.5.4.	Spurious or non-relevant indications	125
3.6.	Recording of findings	126
3.6.1.	Test report forms	126
3.6.2.	Localization schemes	126
3.6.3.	Transfer of findings	126
3.6.4.	Photographic techniques	126
3.6.5.	Writing reports	127
3.7.	Testing techniques for detection of leaks by means of liquid penetrants	128
4.	TEST EQUIPMENT AND MATERIALS (PT).....	129
4.1.	Evaluation of the materials used in the test.....	129
4.1.1.	Penetrating agents	129
4.1.2.	Removers.....	135
4.1.3.	Emulsifiers	136
4.1.4.	Developers.....	136
4.2.	Cleaning equipment.....	141
4.2.1.	Degreasing vapour.....	141
4.2.2.	Ultrasonic cleaning.....	142
4.3.	Compressed air equipment	143
4.3.1.	Air filters	143
4.3.2.	Supply of cold and hot air	143
4.3.3.	Compressed air pistols	143
4.3.4.	Electrostatic pulverizers	144
4.3.5.	Aerosoles.....	145
4.4.	Stationary installations for processing by immersion.....	145
4.4.1.	Stations	145
4.4.2.	Auxiliary equipment.....	149
4.4.3.	Automatic installations.....	150
4.5.	Light sources and light meters	152
4.5.1.	Ultraviolet (UV) radiation sources (black light) and meters for measuring UV radiation intensity	152
4.5.2.	Measurement of ultraviolet radiation intensity	154
4.5.3.	Checking the efficiency of ultraviolet lamps	155
4.5.4.	Cabinets for observation of fluorescent penetrating liquids.....	155
4.6.	Standardized work pieces for evaluating processes and qualifying procedures	156
4.6.1.	Comparator test blocks.....	156
4.6.2.	Non-standardized test pieces for checking penetrability.....	158
4.6.3.	Equipment for checking fluorescence efficiency of UV lamps	158
5.	CODES, STANDARDS, PROCEDURES AND SAFETY (PT)	161
5.1.	Standards applicable to liquid penetrant testing.....	161
5.1.1.	Test methods	161
5.1.2.	Materials for the test.....	162
5.1.3.	American Society of Mechanical Engineers (ASME) Code	162
5.2.	Test specifications and procedures	164

5.2.1.	Interpretation	165
5.2.2.	Formulation of instructions for the test	165
5.3.	National standards for liquid penetrant testing and testing personnel	169
5.4.	Quality control of the test and procedure for its administration	170
5.4.1.	Quality assurance requirements	170
5.5.	Problems of industrial safety in the use of chemical and inflammable products	170
5.5.1.	Personnel hazards and safety with vapour degreasing	171
5.5.2.	Personnel hazards and safety with solvent cleaning	171
5.5.3.	Personnel hazards and safety precautions with acid cleaning	171
5.5.4.	Personnel hazards and safety precautions with salt bath descaling	171
5.5.5.	Applicable safety standards	172
5.5.6.	Safety conditions required for the use of UV light	172
5.5.7.	Drafting of safety instructions for the personnel involved	173
5.5.8.	Safety factors applicable to the test	174
5.5.9.	Problems of industrial safety in the use of chemical and inflammable products	174
6.	PHYSICAL PRINCIPLES AND FUNDAMENTALS OF MAGNETIC PARTICLES (MT)	179
6.1.	Electricity	179
6.1.1.	Current	179
6.1.2.	Voltage	179
6.1.3.	Resistance	180
6.1.4.	Alternating current	180
6.1.5.	Direct current	180
6.2.	Magnetism	182
6.2.1.	Magnetic poles	182
6.2.2.	Permanent magnets	182
6.2.3.	Temporary magnets	183
6.2.4.	Ferro, para and dia magnetic materials	183
6.2.5.	Magnetic fields	185
6.2.6.	Leakage field	186
6.3.	Lines of force	187
6.4.	Magnetic field around a conductor	188
6.5.	Field distribution in magnetic and nonmagnetic conductors	189
6.5.1.	General	189
6.5.2.	Solid nonmagnetic conductor	189
6.5.3.	Solid magnetic conductor	189
6.5.4.	Hollow non-magnetic conductor	190
6.5.5.	Hollow magnetic conductor	191
6.5.6.	Alternating current field distribution	192
6.5.7.	Direct current residual fields	192
6.5.8.	Alternating current residual fields	194
6.5.9.	Solenoid	194
6.5.10.	Electromagnet	194
6.6.	Magnetic flux	195
6.7.	Magnetising force	195
6.8.	Reluctance	195

6.9.	Hysteresis.....	196
6.10.	Magnetic field characteristics.....	197
	6.10.1. Remanence	197
	6.10.2. Permeability	197
6.11.	Saturation.....	198
6.12.	Normal and tangential components of the magnetic field.....	198
6.13.	Electromagnetic waves.....	199
	6.13.1. Visible and ultraviolet light.....	199
6.14.	Terminology and abbreviations.....	200
6.15.	Some derived units and abbreviations.....	201
7.	METHODS AND TECHNIQUES (MT).....	203
7.1.	Methods of magnetization.....	203
	7.1.1. Longitudinal magnetization.....	203
	7.1.2. Circular magnetization.....	203
7.2.	Magnetization techniques.....	204
	7.2.1. Permanent magnets	204
	7.2.2. Electromagnets.....	204
	7.2.3. Coils	205
	7.2.4. Magnetization by passage of current.....	207
	7.2.5. Magnetization technique by induction.....	209
7.3.	Work methods	209
	7.3.1. Remanent fields.....	209
	7.3.2. Continuous field.....	210
	7.3.3. Dry method.....	210
	7.3.4. Wet method	211
7.4.	Testing techniques.....	211
	7.4.1. Testing techniques for work pieces of differing alloy, shape and condition.....	211
	7.4.2. Testing techniques with various types of current.....	212
	7.4.3. Field direction for some specific cases	212
7.5.	Appropriate field intensity.....	217
7.6.	Test sequences.....	217
	7.6.1. Part surface.....	217
	7.6.2. Magnetization of the inspection surface.....	217
	7.6.3. Indicating medium selection and application.....	218
	7.6.4. Interpretation of indications	218
	7.6.5. Demagnetization	218
	7.6.6. Post cleaning	218
7.7.	Miscellaneous field practices	218
	7.7.1. Preparation of the wet and dry suspension for coloured and fluorescent particles.....	218
	7.7.2. Techniques for checking field sensitivity.....	220
	7.7.3. Field indicators for evaluating the sensitivity of the test.....	222
	7.7.4. Reasons for demagnetization	224
	7.7.5. Verification of the remanent fields.....	227
8.	EQUIPMENT AND ACCESSORIES (MT).....	229
8.1.	Knowledge of equipment	229

8.1.1.	Permanent magnets	229
8.1.2.	Electromagnetic yoke	230
8.1.3.	Portable and stationary equipment	230
8.1.4.	Types of current and concepts of testing capacity.....	232
8.1.5.	Demagnetization equipment.....	235
8.1.6.	Maintenance and use of the equipment	237
8.2.	Accessories.....	237
8.2.1.	Contact points.....	237
8.2.2.	Vessels for checking bath concentration	239
8.2.3.	Field indicator (berthold test piece)	240
8.2.4.	Calibration pieces (JIS)	240
8.2.5.	Magnetic field measurement equipment (gauss meter).....	241
8.2.6.	Ultraviolet lamps	242
8.2.7.	Coloured and fluorescent powders.....	244
8.2.8.	Colour for increasing contrast	244
8.2.9.	Morphology of the particles	244
8.3.	Selection of equipment appropriate to the nature of the test	246
8.4.	Special equipment	246
8.4.1.	Portable equipment.....	246
8.4.2.	Stationary installations	247
8.4.3.	Automated equipment	247
9.	CODES, STANDARDS, SPECIFICATIONS AND PROCEDURES (MT)	249
9.1.	Interpretation of procedures for the application of tests using various techniques	249
9.2.	Composition of the procedures including instructions for various methods and techniques	250
9.2.1.	Various materials and shapes	250
9.2.2.	Selection of the equipment.....	250
9.2.3.	Type of current	251
9.2.4.	Selection of inspection media	251
9.2.5.	Field detection	251
9.2.6.	Intensity	251
9.2.7.	Sequence of testing.....	252
9.2.8.	Demagnetization	252
9.2.9.	Post inspection cleaning.....	253
9.2.10.	Acceptance standards	253
9.2.11.	Instructions for level-1 operator (weld inspection by yoke magnetization).....	253
9.3.	Standards	255
9.3.1.	Qualification and certification of personnel.....	255
9.3.2.	Internal specifications and corresponding standards.....	256
9.3.3.	Codes and standards	256
10.	PRESENTATION AND RECORDING OF RESULTS (MT).....	261
10.1.	Preparation of report on the testing	261
10.1.1.	Procedure.....	261
10.2.	Preparation and completion of the report form	261
10.3.	Documentation of the findings	262

10.3.1. To locate the indications within the component	263
10.3.2. Preservation of indications by photography	263
10.3.3. Using transfer techniques	265
10.3.4. Knowledge of documentation system	265
10.3.5. Management and control of complete documentation	266
11. INTERPRETATION OF RESULTS, LIMITATIONS (MT)	267
11.1. Presentation of results	267
11.2. Threshold of detection	267
11.2.1. Evaluation of results according to the criteria of the	
procedure and specifications	267
11.2.2. Additional possibilities for making the results more conclusive	267
11.2.3. Relation of discontinuities to potential failure	268
11.3. Interpretation of findings with reference to the manufacturing process	268
11.3.1. Discontinuity position	269
11.3.2. Processing discontinuities	269
11.3.3. Processing discontinuities and magnetic particle indications	269
11.3.4. Welding discontinuities and magnetic particle indications	270
11.3.5. Service discontinuities responding to magnetic particle testing	271
11.3.6. Non-relevant magnetic particle indications	271
11.4. Applications of magnetic particle testing and other methods of	
testing for surface and subsurface flaws	272
11.4.1. Burst	272
11.4.2. Cold shuts	273
11.4.3. Grinding cracks	274
11.4.4. Heat-affected zone cracking	275
11.4.5. Laps and seams	276
11.4.6. Gas porosity	276
11.5. Safety	277
11.5.1. Implementations of industrial safety standards in	
facilities and equipment and in their operation	278
11.5.2. Hazards of using toxic and inflammable materials	281
11.5.3. Materials, equipment and accessories for the	
protection of persons and facilities	281
BIBLIOGRAPHY	283
RELATED IAEA PUBLICATIONS	285
CONTRIBUTORS TO DRAFTING AND REVIEW	287

1. GENERAL KNOWLEDGE

1.1. Basic principles of non-destructive testing (NDT)

1.1.1. Definition and importance of NDT

Non-destructive testing is the use of physical methods which will test materials, components and assemblies for flaws in their structure without damaging their future usefulness. NDT is concerned with revealing flaws in the structure of a product. It, however, cannot predict where flaws will develop due to the design itself.

All NDT methods have the following common characteristics:

- (a) The application of a testing medium to the product to be tested.
- (b) The changes in the testing medium due to the defects in the structure of the product.
- (c) A means by which it detects these changes.
- (d) Interpretation of these changes to obtain information about the flaws in the structure of the product.

Importance of NDT

NDT plays an important role in the quality control of a product. It is used during all the stages of manufacturing of a product. It is used to monitor the quality of the:

- (a) Raw materials which are used in the construction of the product.
- (b) Fabrication processes which are used to manufacture the product.
- (c) Finished product before it is put into service.

Use of NDT during all stages of manufacturing results in the following benefits:

- (a) It increases the safety and reliability of the product during operation.
- (b) It decreases the cost of the product by reducing scrap and conserving materials, labour and energy.
- (c) It enhances the reputation of the manufacturer as producer of quality goods.

All of the above factors boost the sales of the product which bring more economical benefits to the manufacturer.

NDT is also used widely for routine or periodic determination of quality of the plants and structures during service. This not only increases the safety of operation but also eliminates any forced shut down of the plants.

1.1.2. Types of NDT methods

The methods of NDT range from the simple to the complicated. Visual inspection is the simplest of all. Surface imperfections invisible to the eye may be revealed by penetrant or magnetic methods. If really serious surface defects are found, there is often little point in proceeding to more complicated examinations of the interior by ultrasonics or radiography. NDT methods may be divided into groups for the purposes of these notes: conventional and non-conventional. To the first group may belong the methods which are commonly used and include visual or optical inspection, dye penetrant testing, magnetic particle testing, eddy current testing,

radiographic testing and ultrasonic testing. The second group of NDT methods are those used only for specialized applications and consequently are limited in use. Some of these methods which are being mentioned here merely as a curiosity for the reader include neutron radiography, acoustic emission, thermal and infrared testing, strain sensing, microwave techniques, leak testing, holography etc. It must also be remembered that no one of these methods can give us solutions to all the possible problems, i.e. they are not optional alternatives but rather complementary to each other. The basic principles, typical applications, advantages and limitations of the methods of group one will now be briefly described.

1.1.3. Visual testing (VT)

Often overlooked in any listing of NDT methods, visual inspection is one of the most common and most powerful means of non-destructive testing. Visual testing requires adequate illumination of the test surface and proper eye-sight of the tester. To be most effective visual inspection does however, merit special attention because it requires training (knowledge of product and process, anticipated service conditions, acceptance criteria, record keeping, for example) and it has its own range of equipment and instrumentation. It is also a fact that all defects found by other NDT methods ultimately must be substantiated by visual inspection. Visual testing can be classified as direct visual testing, remote visual testing and translucent visual testing. The most common NDT methods MT and PT are indeed simply scientific ways of enhancing the indication to make it more visible. Often the equipment needed is simple Figure 1.1 a portable light, a mirror on stem, a 2× or 4× hand lens, one illuminated magnifier with magnification 5x or 10×. For internal inspection, light lens systems such as borescopes allow remote surfaces to be examined . More sophisticated devices of this nature using fibre optics permit the introduction of the device into very small access holes and channels. Most of these systems provide for the attachment of a camera to permit permanent recording.

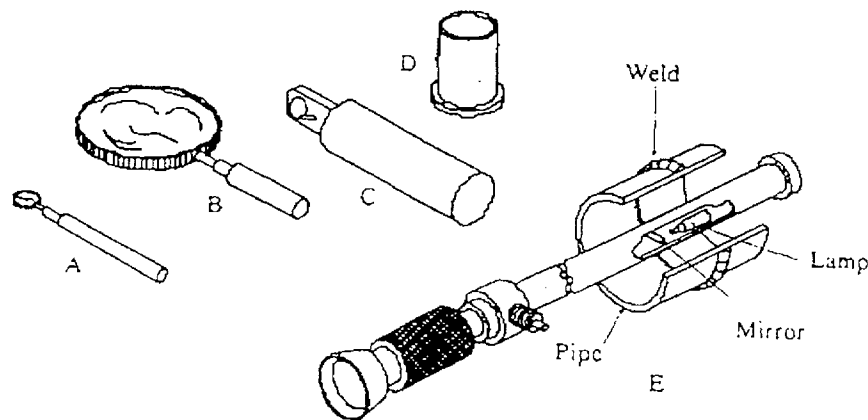

Figure 1.1: Various optical aids used in visual inspection.

- (a) Mirror on stem: may be flat for normal view or concave for limited magnification.
- (b) Hand magnifying glass (magnification usually 2–3×).
- (c) Illuminated magnifier; field of view more restricted than D (magnification 5–10×).
- (d) Inspection glass, usually fitted with a scale for measurement; the front surface is placed in contact with the work (magnification 5–10×).
- (e) Borescope or intrascope with built-in illumination (magnification 2–3×).

The applications of visual testing include:

- (1) Checking of the surface condition of the test specimen.
- (2) Checking of alignment of mating surfaces.
- (3) Checking of shape of the component.
- (4) Checking for evidence of leaking.
- (5) Checking for internal side defects.

1.1.4. Liquid penetrant testing (PT)

This is a method which can be employed for the detection of open-to-surface discontinuities in any industrial product which is made from a non-porous material. This method is widely used for testing of non-magnetic materials. In this method a liquid penetrant is applied to the surface of the product for a certain predetermined time, after which the excess penetrant is removed from the surface. The surface is then dried and a developer is applied to it. The penetrant which remains in the discontinuity is absorbed by the developer to indicate the presence as well as the location, size and nature of the discontinuity. The process is illustrated in Figure 1.2.

Penetrants used are either visible dye penetrant or fluorescent dye penetrant. The inspection for the presence of visible dye indications is made under white light while inspection of presence of indications by fluorescent dye penetrant is made under ultraviolet (or black) light under darkened conditions. The liquid penetrant processes are further sub-divided according to the method of washing of the specimen. The penetrants can be: (i) water-washable, (ii) post-emulsifiable, i.e. an emulsifier is added to the excess penetrant on surface of the specimen to make it water-washable, and (iii) solvent removable, i.e. the excess penetrant is needed to be dissolved in a solvent to remove it from the test specimen surface. In order of decreasing sensitivity and decreasing cost, the liquid penetrant processes can be listed as:

- (1) Post emulsifiable fluorescent dye penetrant.
- (2) Solvent removable fluorescent dye penetrant.
- (3) Water washable fluorescent dye penetrant.
- (4) Post emulsifiable visible dye penetrant.
- (5) Solvent removable visible dye penetrant.
- (6) Water washable visible dye penetrant.

Some of the advantages of liquid penetrant testing are as follows:

- (1) Relatively low cost.
- (2) Highly portable NDT method.
- (3) Highly sensitive to fine, tight discontinuities.
- (4) Fairly simple method.
- (5) Can be used on a variety of materials.
- (6) All surface discontinuities are detected in one operation, regardless of orientation.

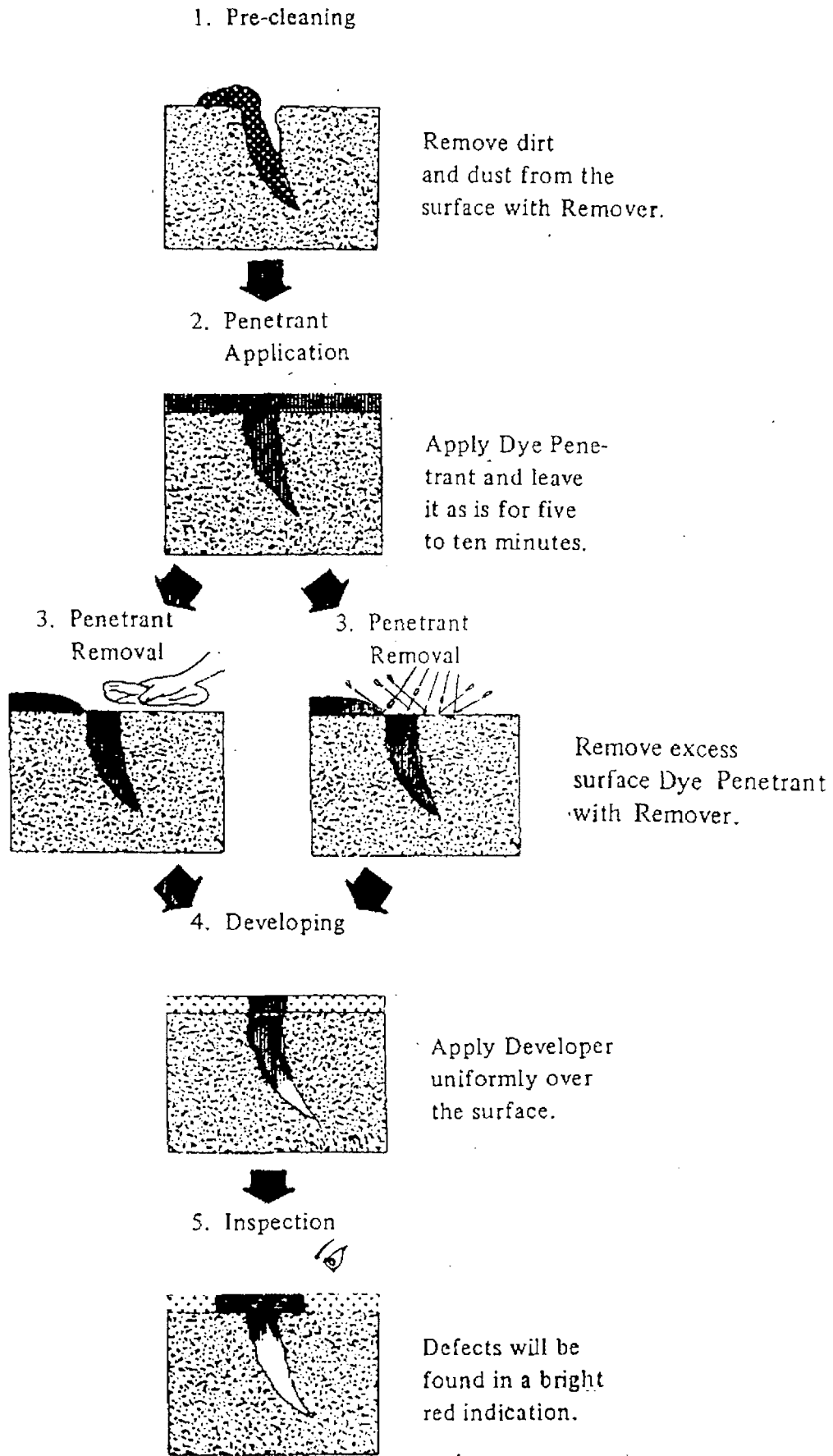

Figure 1.2: Different stages of liquid penetrant process.

Some of the limitations of liquid penetrant testing are as follows:

- (1) Test surface must be free of all contaminants (dirt, oil, grease, paint, rust, etc.).
- (2) Detects surface discontinuities only.
- (3) Cannot be used on porous specimens and is difficult to use on very rough surfaces.
- (4) Removal of all penetrant materials, following the test, is often required.
- (5) There is no easy method to produce permanent record.

1.1.5. Magnetic particle testing (MT)

Magnetic particle testing is used for the testing of materials which can be easily magnetized. This method is capable of detecting open to surface and just below the surface flaws. In this method the test specimen is first magnetized either by using a permanent or an electromagnet or by passing electric current through or around the specimen. The magnetic field thus introduced into the specimen is composed of magnetic lines of force. Whenever there is a flaw which interrupts the flow of magnetic lines of force, some of these lines must exit and re-enter the specimen. These points of exit and re-entry form opposite magnetic poles. Whenever minute magnetic particles are sprinkled onto the surface of such a specimen, these particles are attracted by these magnetic poles to create a visual indication approximating the size and shape of the flaw. Figure 1.3 illustrates the basic principles of this method.

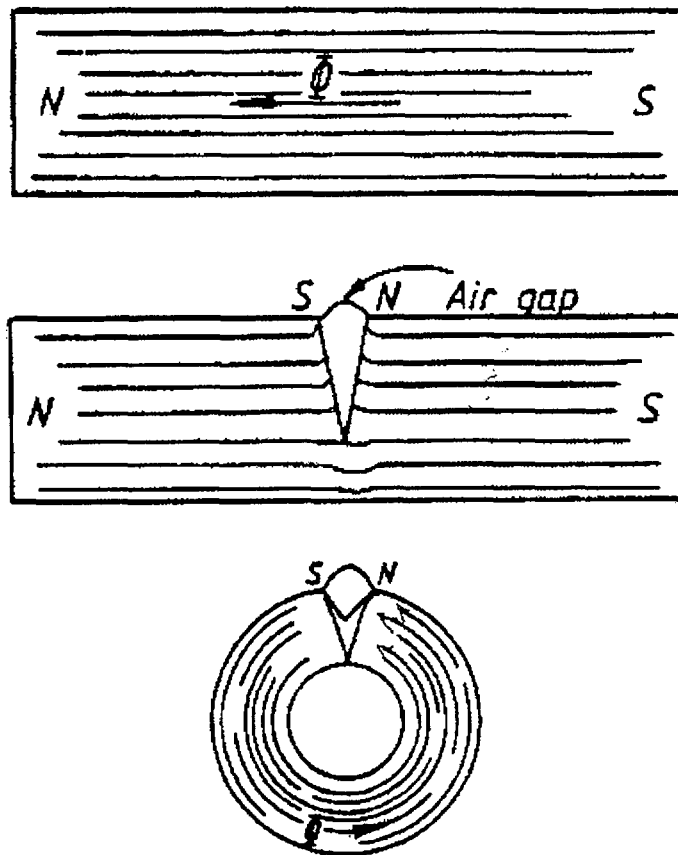

Figure 1.3: Basic principle of magnetic particle testing.

Depending on the application, there are different magnetization techniques used in magnetic particle testing. These techniques can be grouped into the following two categories:

- (a) Direct current techniques: These are the techniques in which the current flows through the test specimen and the magnetic field produced by this flow of current is used for the detection of defects. These techniques are shown in Figure 1.4 (a, b & c).
- (b) Magnetic flux flow techniques: In these techniques magnetic flux is induced into the specimen either by the use of a permanent magnet or by flowing current through a coil or a conductor. These techniques are shown in Figure 1.4 (d-g).

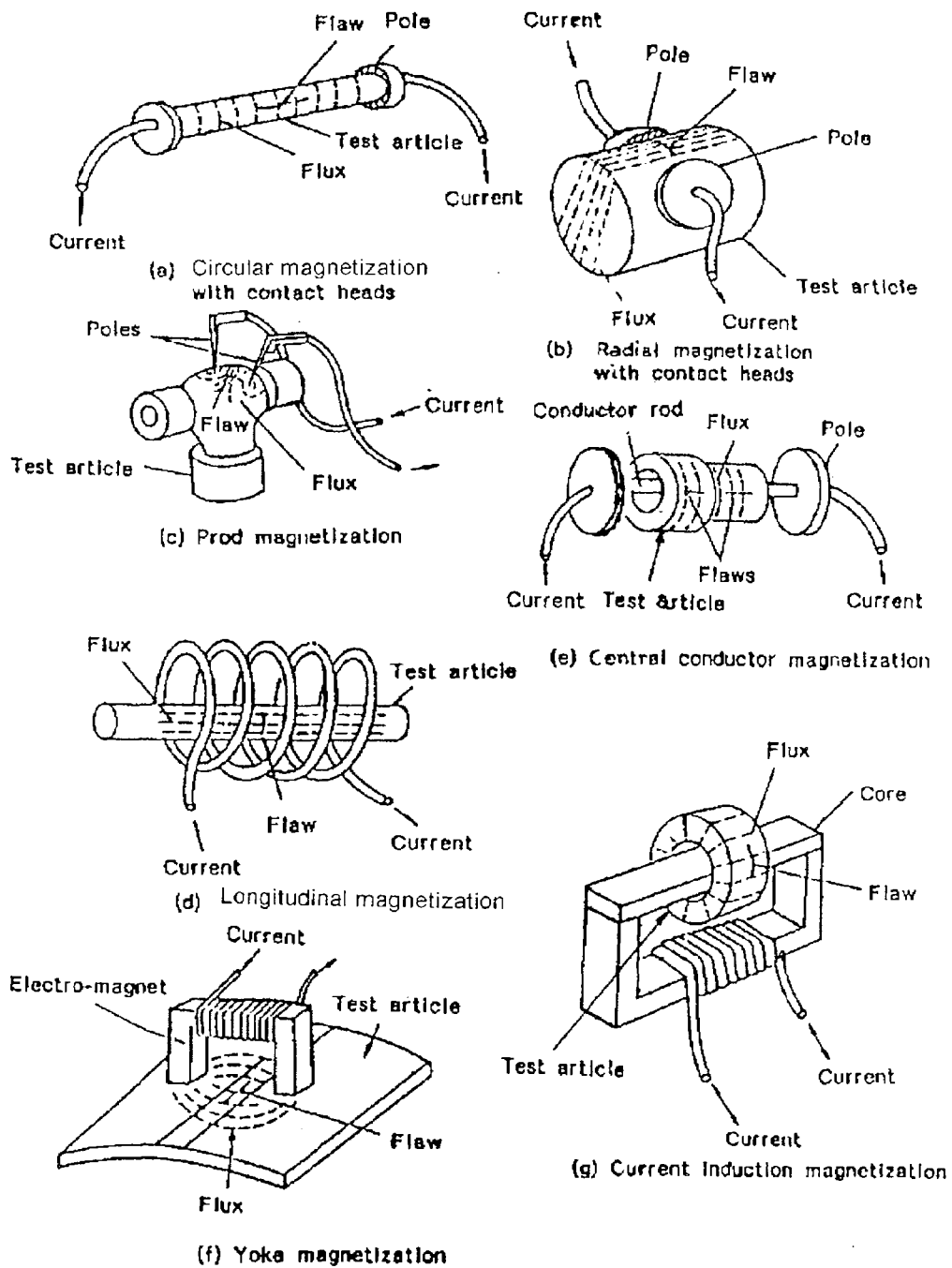

Figure 1.4: Different magnetizations used in magnetic particle testing.

Advantages of magnetic particle testing include the following:

- (1) It does not need very stringent pre-cleaning operation.
- (2) Best method for the detection of fine, shallow surface cracks in ferromagnetic material.
- (3) Fast and relatively simple NDT method.
- (4) Generally inexpensive.
- (5) Will work through thin coating.
- (6) Few limitations regarding the size/shape of test specimens.
- (7) Highly portable NDT method.
- (8) It is quicker.

Some of the limitations of magnetic particle testing include the following:

- (1) Material must be ferromagnetic.
- (2) Orientation and strength of magnetic field is critical.
- (3) Detects surface and near-to-surface discontinuities only.
- (4) Large currents sometimes required.
- (5) "Burning" of test parts a possibility.
- (6) Parts must often be demagnetized, which may be difficult.

1.1.6. Eddy current testing (ET)

This method is widely used to detect surface flaws, to sort materials, to measure thin walls from one surface only, to measure thin coatings and in some applications to measure case depth. This method is applicable to electrically conductive materials only. In the method eddy currents are produced in the product by bringing it close to an alternating current carrying coil. The alternating magnetic field of the coil is modified by the magnetic fields of the eddy currents. This modification, which depends on the condition of the part near to the coil, is then shown as a meter reading or cathode ray tube presentation. Figure 1.5 gives the basic principles of eddy current testing.

There are three types of probes Figure 1.6 used in eddy current testing. Internal probes are usually used for the in-service testing of heat exchanger tubes. Encircling probes are commonly used for the testing of rods and tubes during manufacturing. The uses of surface probes include the location of cracks, sorting of materials, measurement of wall and coating thickness, and case depth measurement.

This method may be used for:

- (1) For the detection of defects in tubings.
- (2) For sorting materials.
- (3) For measurement of thin wall thickness' from one surface only.
- (4) For measuring thin coatings.
- (5) For measuring case depth.

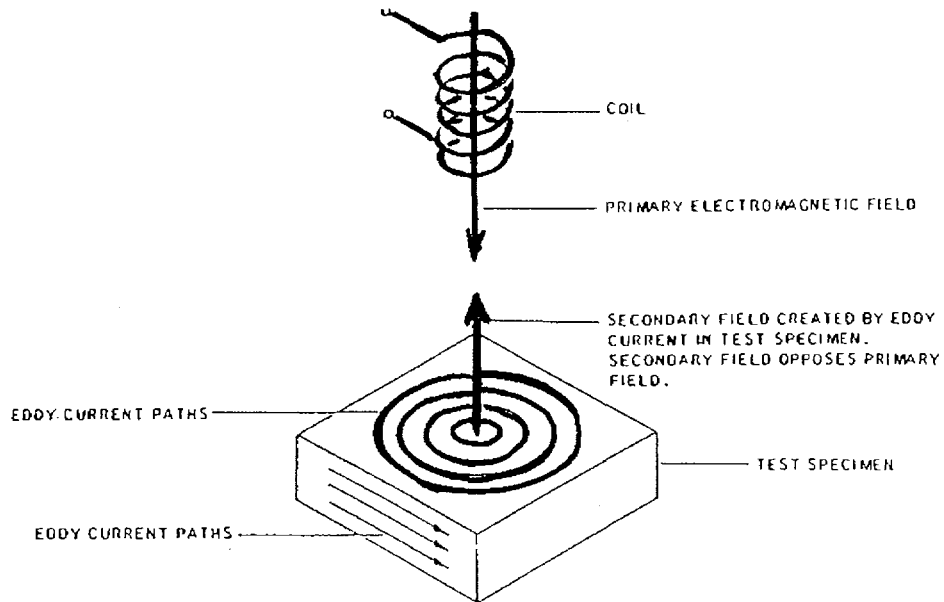

Figure 1.5: (a) Generation of eddy currents in the test specimen.

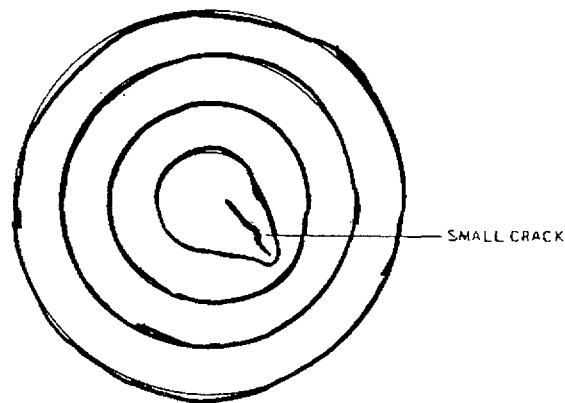
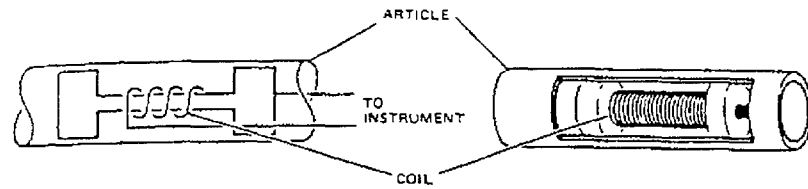

Figure 1.5: (b) Distortion of eddy currents due to defect.

Some of the advantages of eddy current testing include:

- (1) Does not require couplant.
- (2) It gives instantaneous response.
- (3) Has uncomplicated steps during set-up.
- (4) Is extremely sensitive to flaws.
- (5) Is very repeatable.
- (6) High scanning speeds can be used.
- (7) Is very accurate for dimensional analysis of flaws or coating thickness.



(a) *Internal Coil*

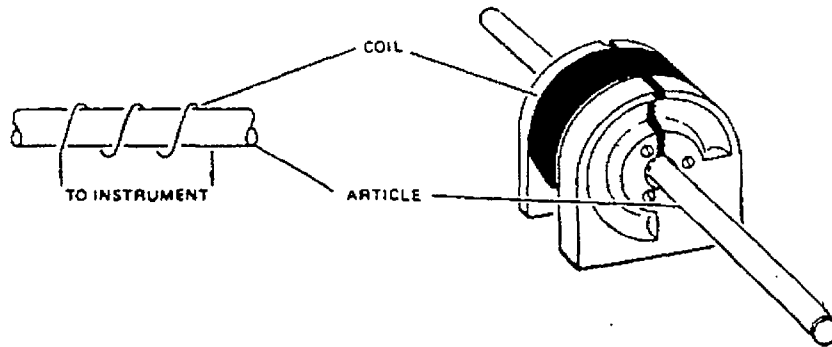

(b) *Encircling Coil*

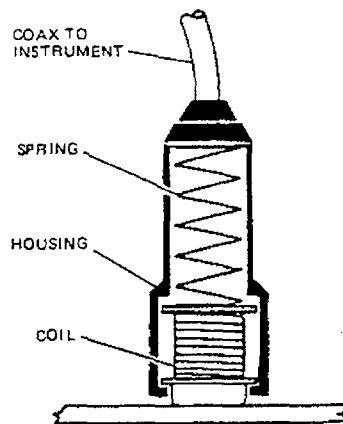

(c) *Surface Probe*

Figure 1.6: Types of probes used in eddy current testing.

Some of the limitations of eddy current testing include the following:

- (1) The theory requires a good academic background in electrical principles and in mathematics.
- (2) Extremely sensitive to surface variations and therefore requires a good surface.
- (3) It is applicable to conductor materials only.
- (4) Can be used on non-magnetic and magnetic material but is not reliable on carbon steel for the detection of subsurface flaws.
- (5) Its depth of penetration is limited.
- (6) Crack tightness and orientation of eddy current flow to a crack or linear discontinuity will affect detectability.

1.1.7. Radiographic testing method (RT)

The radiographic testing method is used for the detection of internal flaws in many different materials and configurations. An appropriate radiographic film is placed behind the test specimen Figure 1.7 and is exposed by passing either X rays or gamma rays (Co-60 & Ir-192 radioisotopes) through it. The intensity of the X rays or gamma rays while passing through the product is modified according to the internal structure of the specimen and thus the exposed film, after processing, reveals the shadow picture, known as a radiograph, of the product. It is then interpreted to obtain data about the flaws present in the specimen. This method is used on wide variety of products such as forgings, castings and weldments. Some of the advantages of radiographic testing include:

- (1) It can be used to inspect large areas at one time.
- (2) It is useful on wide variety of materials.
- (3) It can be used for checking internal malstructure, misassembly or misalignment.
- (4) It provides permanent record.
- (5) No calibration needed on the job site.
- (6) Devices for checking the quality of radiograph are available.
- (7) Interpretation of radiographs can be done in comfortable conditions.

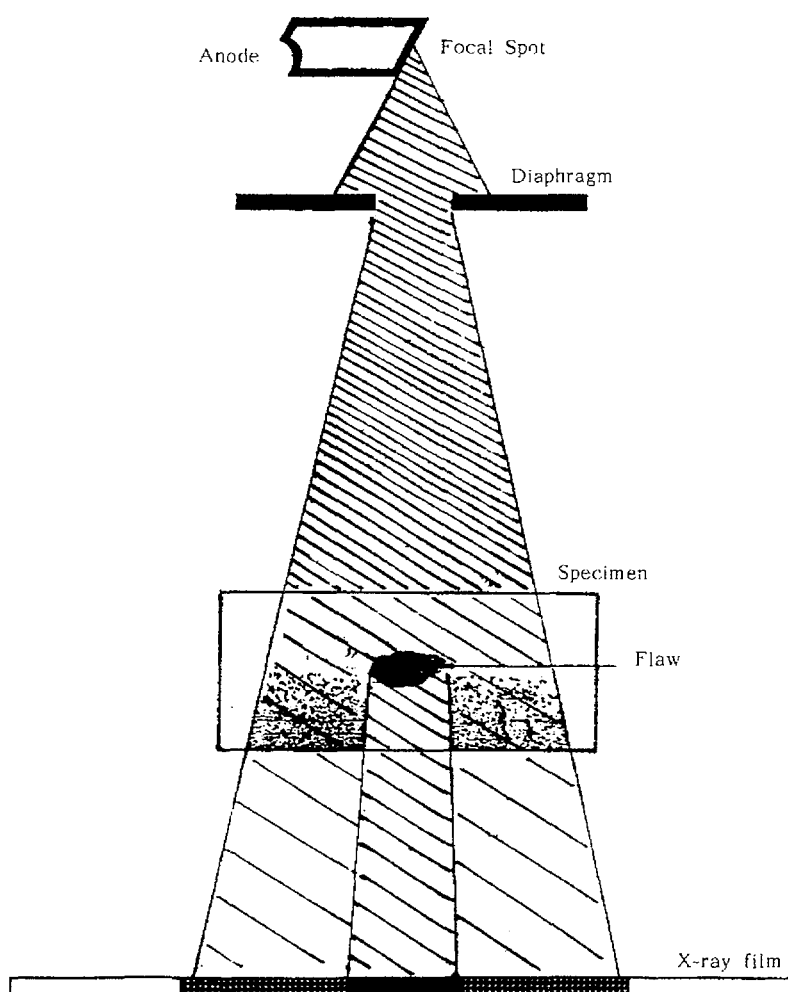

Figure 1.7: Arrangement for radiographic testing method.

Some of the limitations of this method are:

- (1) X rays and gamma rays are hazardous to human health.
- (2) It cannot detect planar defects readily.
- (3) Access to both sides of the specimen is required.
- (4) Thickness range that can be inspected is limited.
- (5) Certain areas in many items cannot be radiographed because of the geometric consideration.
- (6) Sensitivity of inspection decreases with thickness of the test specimen.
- (7) It is more costly.
- (8) It cannot be easily automated.
- (9) It requires considerable skill for the interpretation of the radiographs.
- (10) Depth of discontinuity not indicated.

Personal safety and radiation protection

Effects of radiation

Nuclear radiations are harmful to living tissues. The damage done by radiations is sinister as human senses are not capable of detecting even lethal doses of radiation. The dose of radiations absorbed by human body is expressed in mSv ($1 \text{ mSv} = 100 \text{ rem} = 1 \text{ J/kg}$) which takes into account the biological effectiveness of different types of radiations such as alpha particles, gamma rays, X rays and neutrons etc. The overall outcome of exposure to radiation is initiated by damage to the cell which is the basic unit of the organism. The effects of radiation may be deterministic or stochastic, early or late, of somatic or genetic type.

Somatic effects depend upon three main factors.

- (a) First of these factors is the rate at which the dose is administered. Cells begin the repair processes as soon as some degree of damage has been received. When the body is able to keep up with the damage, no injury or pathological change will be seen in the irradiated individuals. However, the same amount of radiation given all at once would produce a more severe reaction.
- (b) The second is the extent and part of the body irradiated. It is known that certain cells are more sensitive to radiation than others. Hence the overall effect of radiation depends on the extent and part of the body irradiated.
- (c) The third important factor is the age of the affected individual, persons growing physically are in an accelerated stage of cells reproduction and most of the cells in the body are dividing and hence sensitive to radiation. For this reason an exposure of a given amount should be considered more serious for a young person than for an adult.

The somatic effects can either be immediate or delayed. Given below is a summary of immediate effects when the whole body is acutely irradiated with a range of radiation doses:

0–0.25 Sv: No manifested injuries and no clinical effects. Increase of frequency of chromosomal observations in peripheral lymphocytes above 0.15 Sv whole body dose.

0.5–1 Sv: Some changes in blood count picture i.e. reduction in lymphocytes and neutrophils with delayed recovery. Delayed effects may shorten life expectancy. No clinical symptoms .

1–2 Sv: Mild degree of ARS (acute radiation syndrome). Nausea, fatigue, dizziness. Vomiting in 10–50% cases within 24 hours starting 2 hours after exposure or later. Latent period about 3 to 4 weeks. Following the latent period, clinical symptoms appear in a more severe manifestation. No disability.

2–4 Sv: Moderate ARS: nausea, fatigue, dizziness, loss of appetite. Vomiting within 2 hours in 70–90% of exposed persons. Latent period of 2 to 3 weeks where the victim seems relaxed and recovering. The critical period follows with epilation, loss of appetite and general weakness accompanied by fever, inflammation of the mouth and throat, diarrhoea, nose bleeding. Death due to infections could occur in 0–50% of the exposed individuals within 2 months without proper treatment with antibiotics and fluid replacement .

4–6 Sv: Severe ARS: Nausea, weakness, loss of appetite, vomiting within one hour with 100% incidence. Mild diarrhoea in less than 10% of exposed persons with an onset of 3 to 8 hours following the whole body exposure. Headache in 50% of the exposed persons within 4 to 24 hours. Fever in 80–100% cases within 1 to 2 hours. Drop of lymphocytes to about 500 on 2nd–3rd day. Latent period of 1 to 2 weeks followed by severe clinical picture, fever, infections (pneumonia). Death in 50 to 80% of patients within 2 months.

>8 Sv: Lethal ARS: Severe nausea, fatigue and vomiting within 10 minutes followed by fever and diarrhoea and haemorrhage with no latent period. Rate of survival is very poor and death occurs within 2 weeks in 90–100% of exposed individuals. At whole body doses >15 Sv damage on the central nervous system characterized by cramps, involuntary movements of the muscles (ataxia) followed by coma (lethargy). Death occurs within 2 days due to irreversible circulatory cerebral oedema and probably heart failure.

In case of protracted or low dose exposure, ionizing radiation may not produce immediate consequences but some delayed effects may appear a long time after the exposure. These types of effects may be late deterministic effects (life cataract) or stochastic effects (radiation induced cancer or genetic effects).

Genetic effects may be explained in the following way. It is a fact that children inherit characteristics such as appearance, strength, resistance to disease, temperament, etc. from their parents. This happens because each of the parents contributes a characteristic gene to the reproduction process. The genes are contained in the sperm and egg cells of the parents producing them. Radiation can modify and damage the genes. However, genetic effects have never been manifested and proved in exposed to radiation human population groups (neither in A-bomb survivors).

In accordance with the recommendations of the International Commission on Radiological Protection, (ICRP), the dose limit of ionizing radiation is that, which in the light of present knowledge and in the opinion of competent medical authority, is not expected to cause injury to a person at any time during his lifetime and carries negligible probability of cancer induction and genetic malformations.

Occupational workers

As per Schedule II of IAEA Safety Series No. 115, following criteria and dose limits apply:

II-5: The occupational exposure of any worker shall be so controlled that the following limits be not exceeded:

- (a) an effective dose of 20 mSv per year averaged over five consecutive years;
- (b) an effective dose of 50 mSv in any single year;
- (c) an equivalent dose to the lens of the eye of 150 mSv in a year; and
- (d) an equivalent dose to the extremities (hands and feet) or the skin of 500 mSv in a year.

II-6: For apprentices of 16 to 18 years of age who are training for employment involving exposure to radiation and for students of age 16 to 18 who are required to use sources in the course of their studies, the occupational exposure shall be so controlled that the following limits be not exceeded:

- (a) an effective dose of 6 mSv in a year;
- (b) an equivalent dose to the lens of the eye of 50 mSv in a year; and
- (c) an equivalent dose to the extremities or the skin of 150 mSv in a year.

II-7: When, in special circumstances, a temporary change in the dose limitation requirements is approved pursuant to Appendix I:

- (I) the dose averaging period mentioned in para. II-5 (a) may exceptionally be up to 10 consecutive years as specified by the Regulatory Authority, and the effective dose for any worker shall not exceed 20 mSv per year averaged over this period and shall not exceed 50 mSv in any single year, and the circumstances shall be reviewed when the dose accumulated by any worker since the start of the extended averaging period reaches 100 mSv; or
- (II) the temporary change in the dose limitation shall be as specified by the Regulatory Authority but shall not exceed 50 mSv in any year and the period of the temporary change shall not exceed 5 years.

The occupational dose constrain for the whole body exposures in forty years of working lifetime of an individual is 1 Sv. The maximum accumulated dose to a radiation worker of age N years is given by $(N-18) \times 20$ mSv. This means that no person less than 18 years of age can be employed for radiation work.

Radiation workers such as radiographers are subjected to ionizing radiation while performing their work. The amount of radiation dose received depends on various parameters and conditions such as time, distance, shielding and working procedure. Thus, to ensure the safety of radiographers, it is important that supervisors or radiation protection officers continuously observe and record the amount of radiation received by each radiographer working under them. Such an activity is called personnel monitoring.

In general, the main purposes of personnel monitoring are to ensure that the dose limit is not exceeded, to limit the exposure of the individual radiographer, to assist the medical authority in making analysis in the case of accidental over exposure and to provide information about work practices and personal dose history. The other type of monitoring is area monitoring in which the environment around the worker is monitored. This includes checking the equipment containing radioactive sources, and the correctness of the exposure procedures. Personnel monitoring devices

include film badges, pocket dosimeters and thermoluminescence dosimeters (TLD), while the area monitoring is done with the help of radiation survey meters.

Non-occupational workers

For all non-occupational workers and members of the public being exposed to external radiation, the above mentioned dose limits must be reduced appreciably to keep limited the spread of radiation effects if any. The criteria and dose limits specified by Schedule II of the IAEA Safety Series No. 15 for this category of personnel are as given below:

II-8: The estimated average doses to the relevant critical groups of members of the public that are attributable to practices shall not exceed the following limits:

- (a) an effective dose of 1 mSv in a year;
- (b) in special circumstances, an effective dose of up to 5 mSv in a single year provided that the average dose over five consecutive years does not exceed 1mSv per year;
- (c) an equivalent dose to the lens of the eye of 15 mSv in a year; and
- (d) an equivalent dose to the skin of 50 mSv in a year.

1.1.8. Ultrasonic testing (UT)

Ultrasonic inspection is a non-destructive method in which high frequency sound waves are introduced into the material being inspected. Most ultrasonic inspection is done at frequencies between 0.5 and 20 MHz, well above the range of human hearing which is about 20 Hz to 20 kHz. The sound waves travel through the material with some loss of energy (attenuation) due to material characteristics. The intensity of sound waves is either measured, after reflection (pulse echo) at interfaces (or flaw) or is measured at the opposite surface of the specimen (pulse transmission). The reflected beam is detected and analyzed to define the presence and location of flaws. The degree of reflection depends largely on the physical state of matter on the opposite side of the interface, and to a lesser extent on specific physical properties of that matter, for instance, sound waves are almost completely reflected at metal-gas interfaces. Partial reflection occurs at metal-liquid or metal-solid interfaces. Ultrasonic testing has a superior penetrating power than radiography and can detect flaws deep in the test specimen (say up to about 6 to 7 metre of steel). It is quite sensitive to small flaws and allows the precise determination of the location and size of the flaws. The basic principle of ultrasonic testing is illustrated in Figure 1.8.

Ultrasonic testing method is:

- (1) Mostly used for detection of flaws in materials.
- (2) Widely used for thickness measurement.
- (3) Used for the determination of mechanical properties and grain structure of materials.
- (4) Used for the evaluation of processing variables on materials.

Some of the advantages of ultrasonic testing are:

- (1) It has high sensitivity which permits detection of minute defects.
- (2) It has high penetrating power (of the order of 6 to 7 metres in steel) which allows examination of extremely thick sections.
- (3) It has a high accuracy of measurement of flaw position and size.
- (4) It has fast response which permits rapid and automatic inspection.
- (5) It needs access to only one surface of the specimen.

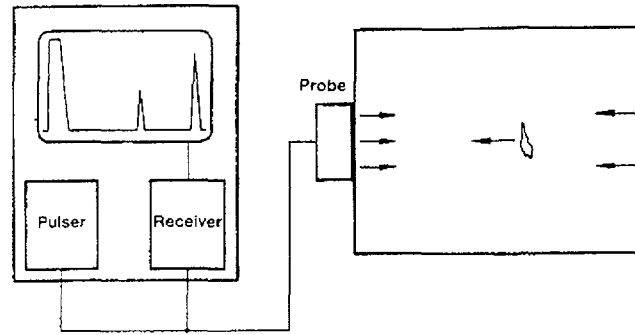

(a) Pulse echo method.

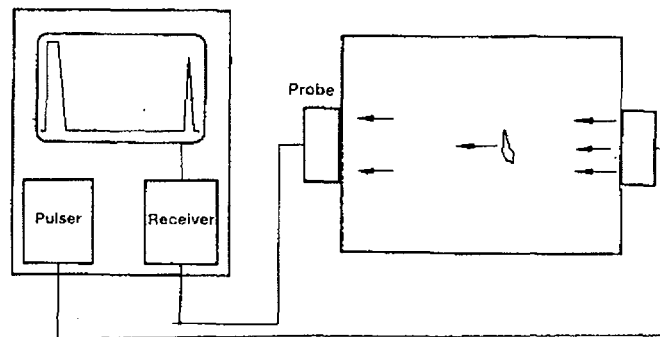

(b) Through transmission method.

Figure 1.8: Basic components of an ultrasonic flaw detection system.

Some of the limitations of this method are:

- (1) Unfavourable geometry of the test specimen causes problems during inspection.
- (2) Inspection of materials having undesirable internal structure is difficult.
- (3) It requires the use of a couplant.
- (4) The probe must be properly coupled during scanning.
- (5) Defect orientation affects defect detectability.
- (6) Equipment is quite expensive.
- (7) Highly skilled manpower is required.
- (8) Reference standards and calibration required.
- (9) Rough surfaces can be a problem and surface preparation is necessary.

1.1.9. Comparison of different NDT methods

Frequently it may be necessary to use one method of NDT to confirm the findings of another. Therefore, various methods must be considered complementary and not competitive, or as optional alternatives. Each method has its particular merits and limitations and these must be taken into account when any testing programme is planned. Table 1.1 gives a summary of the most frequently used NDT methods.

TABLE 1.1. COMPARISON OF VARIOUS NDT METHODS.

Technique	Access requirements	Equipment cost	Inspection cost	Remarks
Optical methods	Can be used to view the interior of complex equipment. One point of access may be enough.	B/D	D	Very versatile; Little skill required; Repays consideration at design stage.
Radiography	Must be able to reach both sides.	A	B/C	Despite high cost, large area can be inspected at one time. Considerable skill required in interpretation.
Ultrasonics	One or both sides (or ends) must be accessible.	B	B/C	Requires point-by-point search hence extensive work needed on large structures; Skilled personnel required.
Magnetic particle	Requires a clean and reasonably smooth surface.	C	C/D	Only useful on magnetic materials such as steel; Little skill required; Only detects surface breaking or near surface cracks.
Penetrant flaw detection	Requires flaw to be accessible to the penetrant (i.e. clean and at the surface).	D	C/D	For all materials; Some skill required; Only detects surface-breaking defects; Rather messy.
Eddy current	Surface must (usually) be reasonably smooth and clean	B/C	C/D	For electrically conductive materials only; For surface breaking flaws; Variations in thickness of coatings, or comparison of materials; For other than simple comparison considerable skill is usually required.

A: Highest cost

D: Lowest cost.

1.2. Materials and defects

1.2.1. Structure of metals and alloys

The properties of metals can be explained in terms of the manner in which the atoms of a metal are bonded together. In this bond, called the "metallic bond" which is formed among similar metal atoms when some electrons in the valence shell separate from their atom and exist

in a cloud surrounding all the positively charged atoms. These positively charged atoms arrange themselves in a very orderly pattern. The atoms are held together because of their mutual attraction for the negative electron cloud Figure 1.9.

Because the electrons are free to move in an electric field, metals conduct electricity. Because free electrons absorb and then radiate back most of the light energy that falls on them, metals are opaque and lustrous. Because free electrons can transfer thermal energy, metals conduct heat effectively. The metallic bond is non-specific, which explains why different metals can be alloyed or joined one to another. It is also non-directional, pulling equally hard in all directions. It therefore binds the metal atoms tightly, so that their cores (nuclei and inner shell electrons) fit closely among one another. The close packing favoured by the metallic bond is best realized in certain regular crystalline structures. These structures, although resistant to tension, offer less resistance to shearing forces, and thus they explain the ductility of metals. They are by definition dense, and thus they explain the comparative heaviness of metals.

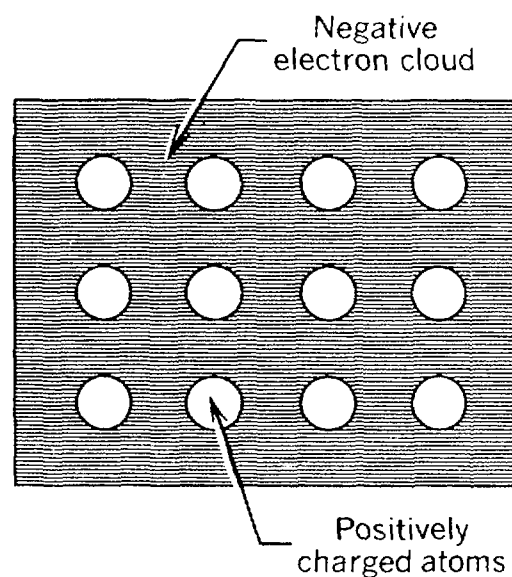

Figure 1.9: Schematic illustration of a metallic bond.

Crystal structure

All matter is considered to be composed of unit substances known as chemical elements. These are the smallest units that are distinguishable on the basis of their chemical activity and physical properties. The elements are composed of atoms which have a distinct structure characteristic of each element. Atoms are too small to be seen with the aid of ordinary microscopes, but the outline of molecules has been detected with such devices as the ion field emission microscope and the electron microscope.

The chemical elements may be roughly classified into three groups: metals, metalloids, and non-metals. Some of the properties that an element must have to be considered a metal are: (1) crystalline structure; (2) high thermal and electrical conductivity; (3) ability to be deformed plastically; (4) metallic luster or high reflectivity of light (5) ability to donate electrons and form a positive ion. Metalloids resemble metals in some respects and non-metals in others. Examples of metalloids are carbon, boron and silicon. The remaining elements are known as non-metals. This includes the inert gases, the elements in Group VII A, and N, O, P and S.

The mechanical properties of metals, then derive from their crystalline structure. That is, the atoms in the solid state of a metal are arranged in definite three dimensional geometric patterns to form crystals or grains of the metal. The network formed by joining the centre of the atoms in a crystal is called the 'space lattice' or 'crystal lattice' of the metal. The smallest volume in a space lattice which properly represents the position of the atoms with respect to each other is known as the unit cell. There are fourteen types of unit cells but the structures of most of the common and commercially important metals in the solid state are constructed from the following three types of unit cells:

(a) Body-centred cubic (BCC)

The body-centred cubic cell is made up of nine atoms. Eight are located on the corners of the cube with the ninth positioned centrally between them Figure 1.10 a. The body-centred cubic is a strong structure, and in general, the metals that are hard and strong are in this form at normal temperatures. These metals include, for example, chromium, molybdenum, barium, tungsten, sodium and vanadium. Steel under 723°C also has this structure, and is called alpha iron or ferrite.

(b) Face-centred cubic (FCC)

Face-centred cubic cells consist of fourteen atoms with eight at the corners and the other six centred in the cube faces Figure 1.10 b. This structure is characteristic of ductile metals, which include aluminium, copper, gold, lead, nickel, platinum and silver. Iron, which is body-centred cubic at room temperature, is also of the face-centred structure in the temperature range from about 910°C to 1,400°C, and is called gamma iron or austenite.

(c) Hexagonal close-packed (HCP)

Seventeen atoms combine to make the hexagonal close-packed unit cell. Seven atoms are located in each hexagonal face with one at each corner and the seventh in the centre. The three remaining atoms take up a triangular position in the centre of the cell equidistant from the two faces Figure 1.10 c. The metals with this structure are quite susceptible to work-hardening. Some of the more commonly used metals that crystallize with this structure are cadmium, cobalt, magnesium, titanium and zinc.

Grains (crystals) and grain boundaries

When a metal is cooled from the liquid state to the solid state, because cooling cannot be exactly the same for every atom, certain atoms will be attracted to each other to form a unit cell ahead of others. This unit cell becomes the nucleus for crystal formation. As the cooling continues other atoms will take up their positions alongside this nucleus and the crystals, or as it is usually referred to for metals, the grain, will grow in size. This orderly growth of the grain continues in all directions until it runs into interference from other grains that are forming simultaneously about other nuclei. Figure 1.11 illustrates the process of the formation of grains and grain boundaries.

Although with some metals with special treatment it is possible to grow single crystals several inches in diameter, in most metals at the usual cooling rates, a great number of crystals are nucleated and grow at one time with different orientations.

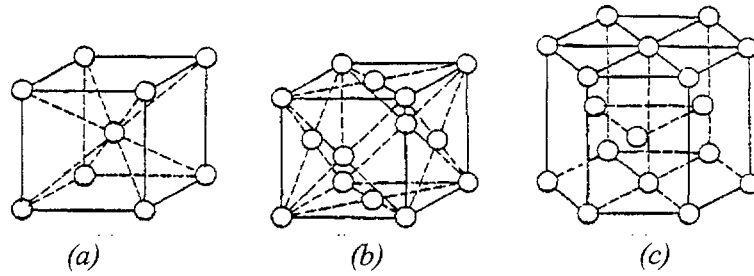

Figure 1.10: Crystal types.

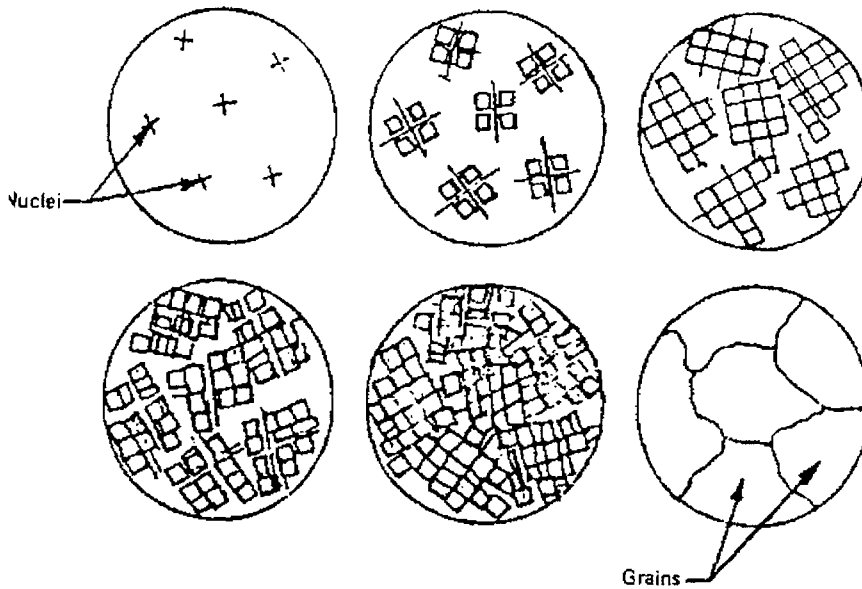

Figure 1.11: Growth of crystals and grains during solidification.

If two grains that have the same orientation meet, they will join to form a larger grain, but if they are forming about different axes, the last atoms to solidify between the growing grains will be attracted to each and must assume compromise positions in an attempt to satisfy a double desire to join with each. These misplaced atoms are in layers about the grains and are known as grain boundaries. They are interruptions in the orderly arrangement of the space lattices and offer resistance to deformation of the metal. A fine-grained metal with a large number of interruptions, therefore, will be harder and stronger than a coarse-grained metal of the same composition and condition.

Structure of alloys

An alloy is a substance that has metallic properties and is composed of two or more chemical elements, of which at least one is a metal. Most commercially used metallic materials are not pure metals but alloys which consist of more than one elements. Some of them may be non-metallic elements. Fundamentally, three modes of arrangement of atoms or phases exist in alloys. These three modes (phases) are; pure metal, solid solution and intermetallic compound. For simplicity of illustration, an alloy with two elements A and B, shall be considered in the following discussion.

(a) Pure metal

There exist no B-atoms in A-crystal grains and no A-atoms in B-grains, i.e. mixture of pure A- and B-crystal grains. A and B metals are mutually insoluble. This complete lack of intersolubility is theoretically almost impossible (The solubility of one component in an other may be exceedingly small but hardly zero).

(b) Solid solution

Any solution is composed of two parts: a solute and a solvent. The solute is the minor part of the solution or the material which is dissolved, while the solvent constitutes the major portion of the solution. There exist B-atoms (solute) in A-crystal grains (solvent). Solid solutions are of two types: substitutional solid solutions and interstitial solid solutions.

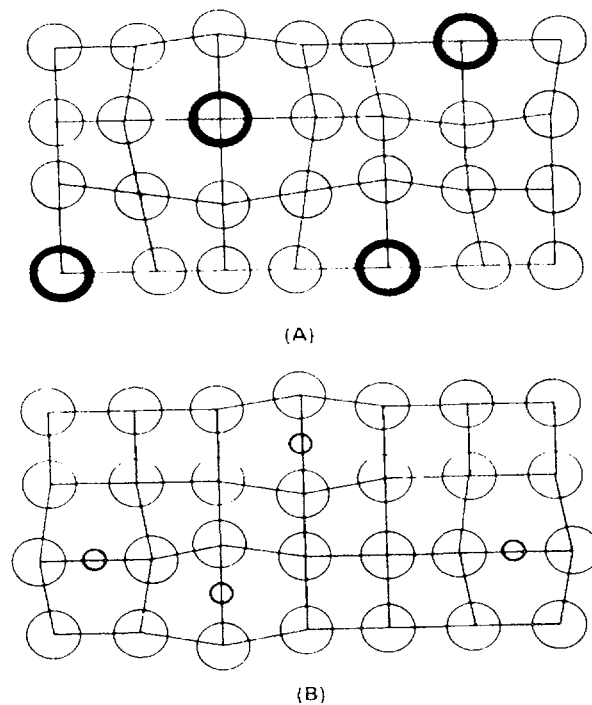

Figure 1.12: Schematic illustration of substitutional and interstitial solid solutions.

(i) Substitutional solid solution

A substitutional solid solution is a solution of two or more elements with atoms that are nearly of the same size. This requirement is necessary in that the alloying atoms need to replace the regular atoms in the lattice structure as shown in Figure 1.12 (a). Examples of substitutional solid solutions are gold dissolved in silver, and copper dissolved in nickel.

(ii) Interstitial solid solution

Interstitial solid solutions are made up of alloying elements or atoms that differ greatly in size. The alloying atoms must be small enough to fit within the lattice structure of the base

material. This type of solid solution is called interstitial, and is illustrated in Figure 1.12 (b). Small amounts of carbon, nitrogen, and hydrogen can alloy interstitially in iron and other metals.

(iii) Intermetallic compounds

These are generally formed between chemically dissimilar metals and are combined by following the rules of chemical valence. Since they generally have strong bond (ionic or covalent), their properties are essentially non-metallic. Elements A and B form an intermetallic compound AB. In contrast to a solid solution, the ratio of the number of A-atoms to B-atoms is fixed ($m:n$), and the crystal structure is quite different from both A- and B-metal crystals and usually very complicated. Almost all the intermetallic compounds are very hard and brittle due to their complicated crystal structure.

Allotropic transformation

Many metals exist in more than one crystal structure. The transformation when a metal changes from one crystal arrangement to another is called an “allotropic transformation” or “phase transformation”. Iron exists in three allotropic forms: BCC (below 1330°F or 704°C), FCC (above 1670°F or 911°C), and delta iron (between 2550°F or 1398°C and 2800°F or 1538°C). The exact temperature is determined by the amount of carbon and other alloying elements in the metal.

The properties of iron and steel are governed by the phase transformations they undergo during processing. Understanding these transformations is essential to the successful welding of these metals.

Steel is an iron alloy containing less than two per cent carbon. The presence of carbon alters the temperatures at which freezing and phase transformations take place. The addition of other alloying elements also affects the transformation temperatures. Variations in carbon content have a profound affect on both the transformation temperatures and the proportions and distributions of the various phases (austenite, ferrite, and cementite). The iron-carbon phase diagram is shown in Figure 1.13.

On cooling, delta ferrite to austenite transformation occurs at 2535°F (1390°C) in essentially pure iron, but in steel, the transformation temperature increases with increasing carbon content to a maximum of 2718°F (1492°C). Steels with more than 0.5 per cent carbon freeze directly to austenite at a temperature below 2718°F (1492°C), and therefore, delta ferrite does not exist in these steels.

On further cooling, austenite transforms to ferrite plus iron carbide. This is one of the most important transformations in steel. Control of it is the basis for most of the heat treatments used for hardening steel. This transformation occurs in essentially pure iron at 1670°F (910°C). In steel with increasing carbon content, however, it takes place over a range of temperatures between boundaries A_3 and A_1 , Figure 1.13. The upper limit of this temperature range (A_3) varies from 1670°F (910°C) down to 1333°F (723°C). For example, the A_3 of a 0.10 per cent carbon steel is 1600°F (870°C), while for a 0.50 per cent carbon steel it is 1430°F (775°C). Thus, both at high and low temperature the presence of carbon promotes the stability of austenite at the expense of delta and alpha ferrite. The lower temperature of the range (A_1) remains at 1330°F (723°C) for all plain carbon steels, regardless of the carbon level.

Austenite can dissolve up to 2.0 per cent of carbon in solid solution, but ferrite can dissolve only 0.025 per cent. At the A_1 temperature, austenite transforms to ferrite and an intermetallic compound of iron and carbon (Fe_3C), called cementite. Ferrite and cementite in adjacent platelets form a lamellar structure, known as pearlite.

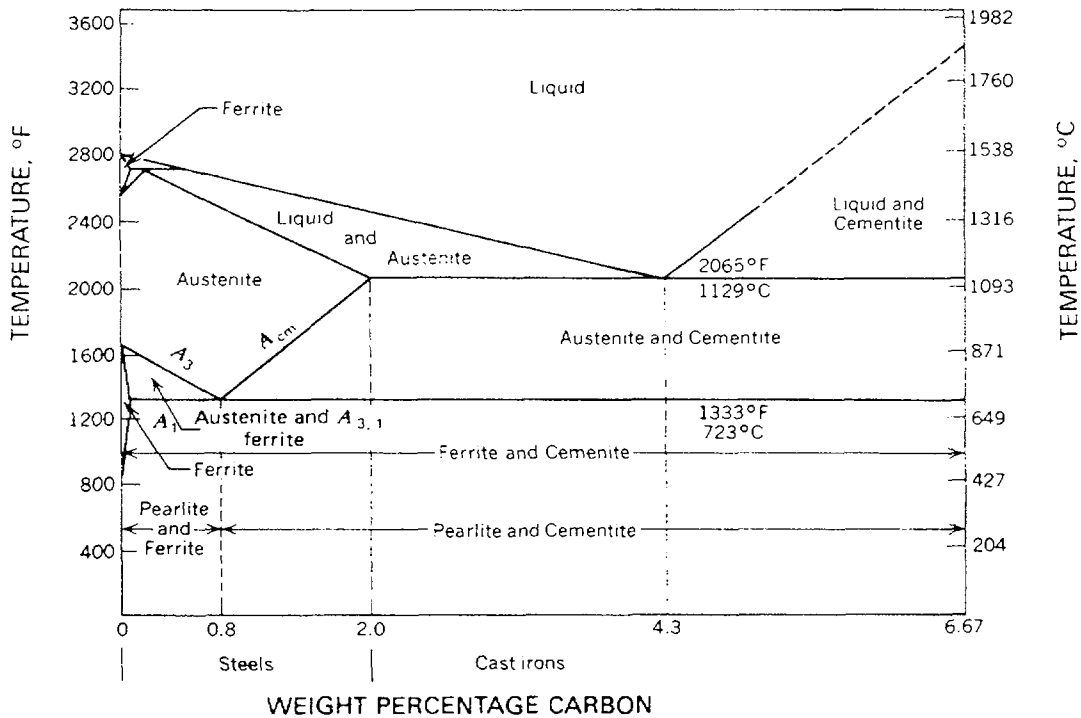

Figure 1.13: The iron-carbon phase diagram.

Most of the common alloying elements added to steel further alter the transformation temperatures. Room temperature microstructures of iron-carbon alloys at the equilibrium conditions covered by this diagram include one or more of the following constituents:

- (1) Ferrite: A solid solution of carbon in alpha iron.
- (2) Pearlite: A mixture of cementite and ferrite that forms in plates or lamellae.
- (3) Cementite: Iron carbide, Fe_3C , present in pearlite or as massive carbides in high carbon steels.
- (4) Austenite: A solid mixture of carbon in gamma iron.
- (5) Leborite: A eutectic mixture of austenite & cementite.

When carbon steels are slowly cooled from the austenitic temperature range, the relative amounts of these three constituents at room temperature depend on the chemical composition. However, austenite decomposition is suppressed when the cooling rate is accelerated. When transformation does begin, it progresses more rapidly, and larger volumes of pearlite are formed. As the cooling rate is further increased, the pearlite lamellae become finer (closely spaced platelets).

At fast cooling rates, still lower transformation temperatures are encountered, and a feathery distribution of carbides in ferrite is formed instead of pearlite. This feathery arrangement of shear needles with fine carbides in a ferrite matrix is called bainite. It has significantly higher strength and hardness and lower ductility than fine pearlitic structures. With very fast cooling rates (severe quenching), martensite forms. Martensite is the hardest austenite decomposition product. When the cooling rate is fast enough to form 100 per cent martensite, no further increases in hardness can be achieved by faster quenching.

The decomposition of austenite is an important consideration in the welding of steel alloys because the weld metal and parts of the heat-affected zone undergo this transformation.

1.2.2. Properties of materials (metallic & non-metallic)

Metallic materials

Mechanical properties are defined as the properties of a material that reveal its elastic and inelastic (plastic) behaviour when force is applied, thereby indicating its suitability for mechanical applications, for example, modulus of elasticity, tensile strength, elongation, hardness, and fatigue limit. Other mechanical properties, not mentioned specifically above, are yield strength, yield point, impact strength, and reduction of area, to mention a few of the more common terms. In general, any property relating to the strength characteristics of metals is considered to be a mechanical property. Physical properties relate to the physics of a metal such as density, electrical properties, thermal properties, magnetic properties and the like. These and other properties will be described here in slightly more detail.

Elasticity and plasticity

When stress or force is applied to a metal, it changes shape. For example a metal under a compressive stress will shorten and metal in tension will lengthen. This change in shape is called strain. The ability of metal to strain under load and then return to its original size and shape when unloaded is called elasticity. The elastic limit (proportional limit) is the greatest load a material can withstand and still spring back into its original shape when the load is removed. Within the elastic range stress is proportional to strain and this is known as Hooke's law. The relationship between applied stress or load and the consequent strain or change in length is shown in Figure 1.14. The end of the straight line portion is known as the elastic limit. A point on the curve slightly higher than the elastic limit is known as the yield point or yield strength. The allowable or safe load for a metal in service should be well below the elastic limit. If higher loads are applied, however, the range of elasticity or elastic deformation is exceeded and the metal is now permanently deformed. Now it will not return to its original dimensions even when the load is removed. For this reason, the area of the stress strain curve beyond the elastic limit is called the plastic range. It is this property that makes metals so useful. When enough force is applied by rolling, pressing or hammer blows, metals can be formed, when hot or cold, into useful shapes. If the application of load is increased in the plastic region a stage comes when the material fractures.

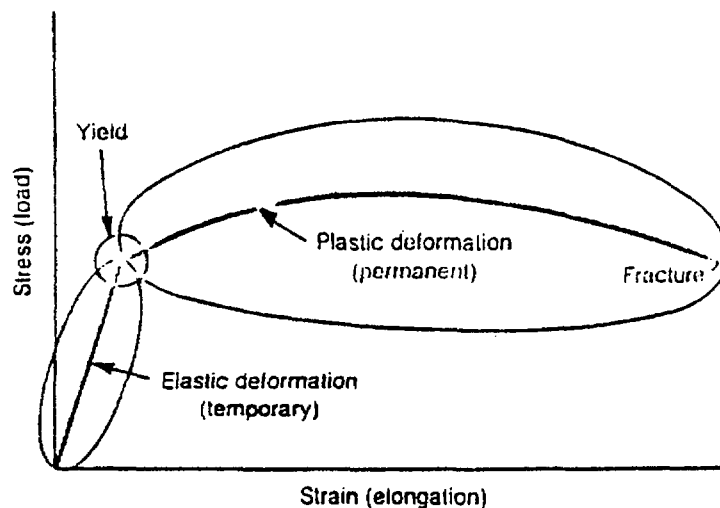

Figure 1.14: Stress-strain curve showing elastic and plastic portions of a typical curve.

A very important feature of the stress-strain curve must be pointed out. The straight-line or elastic part of the stress-strain curve of a given metal has a constant slope. That is, it cannot be changed by changing the microstructure or heat treatment. This slope, called the modulus of elasticity, measures the stiffness of the metal in the elastic range. Changing the hardness or strength does not change the stiffness of the metal. There is only one condition that changes the stiffness of any given metal, that is temperature. The stiffness of any metal varies inversely with its temperature; that is, as temperature increases, stiffness decreases, and vice versa.

Strength

The strength of a metal is its ability to resist change in shape or size when external forces are applied. There are three basic types of stresses namely tensile, compressive, and shear. When we consider strength, the type of stress to which the material will be subjected must be known. Steel has equal compressive and tensile strength, but cast iron has low tensile strength and high compressive strength. Shear strength is less than tensile strength in virtually all metals.

The tensile strength of a material can be determined by dividing the maximum load by the original cross-sectional area before testing. Thus

$$\text{Tensile strength} = \frac{\text{Maximum load}}{\text{Original cross-sectional area}} \text{ ----- (1.1)}$$

Metals are “pulled” on a machine called a tensile tester. A specimen of known dimensions is placed in the tensile testing machine and loaded slowly until it breaks. Instruments are sometimes used to make a continuous record of the load and the amount of strain (proportional change in length). This information is put on a graph called a stress-strain diagram. A stress-strain diagram can be made for any metal.

Hardness

The hardness of a metal is its ability to resist being permanently deformed. There are three ways that hardness is measured; resistance to penetration, elastic hardness, and resistance to abrasion. Hardness varies considerably from material to material. This variation can be illustrated by making an indentation in a soft metal such as aluminium and then in a hard metal such as alloy tool steel. The indentation could be made with an ordinary centre punch and a hammer, giving a light blow of equal force on each of the two specimens. In this case just by visual observation one can tell which specimen is harder. Of course, this is not a reliable method of hardness testing, but it does show one of the principles of hardness testers; measuring penetration of the specimen by an indenter or penetrator, such as a steel ball or diamond point.

Rockwell, Vicker and Brinell hardness testers are the most commonly used types of hardness testers for industrial and metallurgical purposes. Heat treaters, inspectors, and many others in industry often use these machines. The Rockwell hardness test is made by applying two loads to a specimen and measuring the difference in depth of penetration in the specimen between the minor load and the major load.

The Brinell hardness test is made by forcing a steel ball, usually 10 millimetres (mm) in diameter, into the test specimen by using a known load weight and measuring the diameter of the resulting impression. A small microscope is used to measure the diameter of the impressions. Various loads are used for testing different materials, for example, 500 kilograms (kg) for soft materials such as copper and aluminium and 3000 kg for steels and cast irons.

Generally the harder the material is, the greater its tensile strength will be, that is, its ability to resist deformation and rupture, when a load is applied.

Ductility

The property that allows a metal to deform permanently when loaded in tension is called ductility. Any metal that can be drawn into a wire is ductile. Steel, aluminium, gold, silver, and nickel are examples of ductile metals.

The tensile test is used to measure ductility. Tensile specimens are measured for area and length between gauge marks before and after they are pulled. The per cent of elongation (increase in length) and the per cent of reduction in area (decrease of area at the narrowest point) are measures of ductility. A high per cent elongation (about 40%) and reduction in area (about 70 per cent) indicates a high ductility. A metal showing less than 20 per cent elongation would have low ductility.

Malleability

The ability of a metal to deform permanently when loaded in compression is called malleability. Metals that can be hammered or rolled into sheets are malleable. Most ductile metals are also malleable, but some very malleable metals such as lead are not very ductile and cannot be drawn into wire easily. Metals with low ductility, such as lead, can be extruded or pushed out of a die to form wire and other shapes. Some very malleable metals are lead, tin, gold, silver, iron and copper.

Brittleness

A material that will not deform plastically under load is said to be brittle. Excessive cold-working causes brittleness and loss of ductility. Cast iron does not deform plastically under a breaking load and is therefore brittle.

A very sharp “notch” that concentrates the load in a small area can also reduce plasticity. Notches are common causes of premature failure in parts. Weld undercut, sharp shoulders on machined shafts, and sharp angles on forgings and castings are examples of unwanted notches (stress raisers).

Notch toughness

Notch toughness (impact strength) is the ability of a metal to resist rupture from impact loading when there is a notch or stress raiser present. A metal may show high ductility or strength when tensile tested or be hard or soft when hardness tested, but often the behaviour of metals under shock loads is not seemingly related to those properties. Of course, as a rule, a brittle metal such as grey cast iron will fail under low shock loads; that is, its shock resistance is low, and soft wrought iron or mild steel has a high shock resistance. But soft, coarse-grained metals will have lower shock resistance than fine-grained metals. A notch or groove in a part will lower the shock resistance of a metal, so a specific notch shape and dimension is machined on the test specimen in order to give uniform results.

In general, the tensile strength of a metal changes in proportion to hardness. However, this relationship does not always hold true at high hardness levels or with brittle materials because these materials are more sensitive to stress concentrations, or notches, and may fracture prematurely when stressed in tension.

Conductivity

Conductivity is a measure of the ability of a material to conduct electric current. It is the reciprocal of resistivity. Conductivity is commonly expressed as mhos per metre since the unit of resistivity is the ohm. The conductivity of metallic elements varies inversely with absolute temperature over the normal range of temperatures but at temperatures approaching absolute zero the imperfections and impurities in the lattice structure of a material make the relationship more complicated. Metals and materials exhibit a wide range of conductivity. Between the most conductive substances (silver and copper) and the most resistive (polystyrene for example) the difference amounts to 23 orders of magnitude.

Non-metallic materials

Ceramics

Ceramics offer unique properties as engineering materials, notably exceptionally high hardness and resistance to abrasion and corrosion as well as high temperature properties considerably superior to those of any metals. However, they are less ductile, intrinsically brittle and susceptible to thermal shock which can limit their maximum service temperature on applications involving thermal cycling. Resistance to thermal shock is directly dependent on a low coefficient of thermal expansion and high thermal conductivity, which properties differ appreciably between different ceramic materials.

The fabrication of ceramics does not set particular problems since they can be formed by traditional techniques such as slip casting wet pressing and extrusion; and by such modern methods as injection moulding, isostatic pressing, tape casting and dry pressing.

Ceramics which can be classified (or are usable or potentially usable) as engineering materials currently embrace: (i) alumina, (ii) beryllia (beryllium oxide) and boron nitride, (iii) porcelain (aluminium silicates), (iv) steatite and forsterite (magnesium silicates), (v) silicon nitride and silicon carbide, (vi) titanium diboride and (vii) vitreous carbon.

Ceramics are finding an increasing use in the fabrication of electronic components, engineering components, medicine and dentistry and jewellery.

Cermets

The use of ceramic-coated metals and ceramic-metal combinations has now assumed significant proportions, particularly in the fields of practical nuclear physics (e.g. parts for nuclear reactors) and jet engine manufacture. Metal ceramic combinations are of two types: a ceramic coating on the metal, or a chemical and mechanical combination of metals and ceramics in a cermet material. Both are essentially attempts to produce satisfactory high-temperature materials, either with reduced costs and better availability or with an overall performance superior to existing metal or ceramic materials on their own. Broadly speaking the mechanical properties of these two types of materials represent extremes. Metals have high tensile strength and shock resistance, but lose these properties rapidly with increasing temperature. Ceramics of the refractory kind have extremely high melting points and excellent general stability, but are low in tensile strength and both mechanical and thermal shock resistance. The demand for materials combining the favourable features of both metals and ceramics is increasing; hence the development of combinations of ceramics with metals over the past few years.

Normally cermets are formed by techniques similar to those employed in powder metallurgy. The ceramic content usually comprises refractory oxides, carbides or nitrides whilst the metal powder component is usually chromium, nickel, molybdenum or titanium. The resulting

properties are different from those of either of the separate constituents. A number of cermets have particularly high melting points, best realized in an open flame.

Composites

A composite is a material in which a stronger, sometimes fibrous material is usually combined with another to reinforce or strengthen the resultant mass. The needs of the aerospace industry led to the development and acceptance of composite materials. Low weight, high strength and great rigidity were of paramount interest of military aviation. These same qualities are also in demand in many non-military applications.

The most common forms of composites are based on a plastic matrix. The fibrous reinforcing material may be in sheet form, as in thermoset plastic laminates; filament form, woven or random, as in glass reinforced plastics; or short fibre form as in filled or reinforced thermoplastics. These materials are well established and widely available.

In the case of thermoset laminate composites, phenolic, melamine and epoxide are the main resin systems used with paper, cotton fabric, glass fabric and asbestos as the main alternative reinforcing materials.

Ceramic and metal composites have remained relatively undeveloped as general engineering and constructional materials, largely on account of high cost. There are, however, numerous applications of 'filled' and 'laminated' metal forms which qualify as composites under the general description.

Concrete

Concrete is a mixture of stone and sand held together by a hardened paste of hydraulic cement and water. When the ingredients are thoroughly mixed, they make a plastic mass which can be cast or moulded into a predetermined size and shape. When the cement paste hardens, the concrete becomes very hard like a rock. It has great durability and has the ability to carry high loads especially in compression.

The required strength and properties of concrete can be obtained by careful selection of its ingredients, correct grading of ingredients, accurate water additions and adopting a good workmanship in mixing, transportation, placing, compaction, finishing, and curing of concrete in the construction work.

The main ingredients of concrete are cement, coarse aggregate (i.e. screenings, gravel, etc.), fine aggregate (i.e. sand), chemical admixtures (if necessary) and fibrous materials (as necessary). Aggregates in concrete constitute by far the bulk of the mass.

1.2.3. Discontinuities and defects in metallic materials

Whenever there is a change in the homogeneity and uniformity of properties within a material, it can invariably be attributed to the presence of discontinuities or imperfections (lack of material) within the material. Starting from the dislocations and atomic structure irregularities, the discontinuities can take various shapes and forms such as gas inclusions (microporosity, porosity, blowholes, pipes, voids), cracks, metallic inclusions, lack of penetration, lack of fusion, shrinkage, laps and seams, etc.

Discontinuities can be divided into three general categories inherent, processing, and service.

(i) Inherent discontinuities are usually formed when the metal is molten. There are two further sub classifications. Inherent wrought discontinuities relate to the melting and solidification of the original ingot before it is formed into slabs, blooms, and billets. Inherent cast discontinuities relate to the melting, casting and solidification of a cast article.

(ii) Processing discontinuities are usually related to the various manufacturing processes such as machining, forming, extruding, rolling, welding, heat treating, and plating. During the manufacturing process, many discontinuities that were subsurface will be made open to the surface by machining, grinding, etc.

(iii) Service discontinuities are related to the various service conditions, such as stress, corrosion, fatigue and erosion. The discontinuities may alter the local stress distribution and, in addition, may affect the mechanical or chemical (corrosion resistance) properties.

Discontinuities should be characterized not only by their nature, but also by their shape. Planar type discontinuities, such as cracks, laminations, incomplete fusion, and inadequate joint penetration, create serious notch effects. Three-dimensional discontinuities create almost no notch effect, but amplify stresses by reducing the weldment area. Therefore, the characteristics of discontinuities which should always be considered, include the size, acuity or sharpness, orientation with respect to the principal working stress and residual stress, location with respect to the exterior surfaces and the critical sections of the structure.

All the above discontinuities are described under the individual processes in Sections 1.3 and 1.4.

1.3. Processing and defects

1.3.1. Primary processes and related defects

Ingot casting and related defects

A casting suitable for working or remelting is called ingot. The moulds into which molten metal is poured to form ingots are made of grey cast iron, meehanite with large graphite flakes, and anodized aluminium alloys. The inside surface of the mould is frequently coated with suitable materials to help form a smooth ingot surface. The slab or billet is normally the starting point for actual forming of articles or materials. Typical discontinuities found in ingot Figure 1.15 are non-metallic inclusions, porosity and pipe. Most of these discontinuities in the ingot are in the upper portion and can be easily eliminated by cropping off the top of the ingot. The ingot after the hot top is cropped off is called a bloom. The blooms then can be further processed to form slabs and billets Figure 1.16.

Casting processes

A commonly used method of forming metal objects of complex shapes is by pouring molten metal into a mould in which it sets to the required shape. The mould is then broken away to expose the casting, or the design of the mould is such that it can be separated without damage and re-used. The moulds are usually formed from patterns which can be used many times over, if necessary, and their design is critical in that 'feed' and 'vent' holes must be carefully positioned in the mould to permit the metal to flow freely into all parts Figure 1.17. Problems that can occur

are interaction on cooling. It is also unlikely that the crystal structure of a casting will be optimum in all parts so that its strength may be less than with other methods of fabrication. Various casting processes include sand casting, permanent mould casting, die casting, centrifugal casting and shell mould casting etc. Since the casting process is complex and a large number of variables need to be controlled to get a good quality product and since it is not possible to give all the details here, only the principles and salient features of the above mentioned processes of casting are briefly presented.

Sand casting

In this case a sand mould is used for casting the desired shape of the required alloy. A sand mould may be defined as a pre-formed sand container into which molten metal is poured and allowed to solidify. In general sand moulds are destroyed as the casting is removed from them. Sand moulds make it possible to cast complex shapes that might not be possible otherwise.

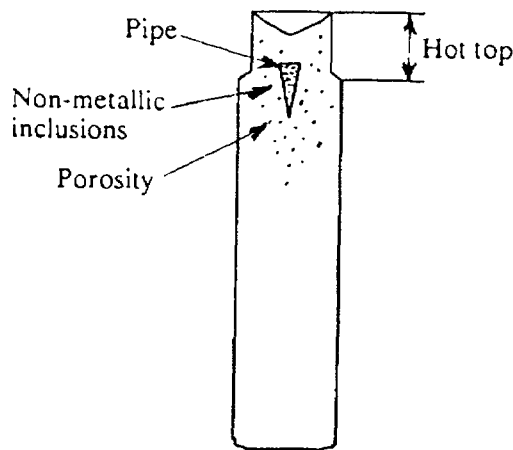

Figure 1.15: Typical defects in an ingot.

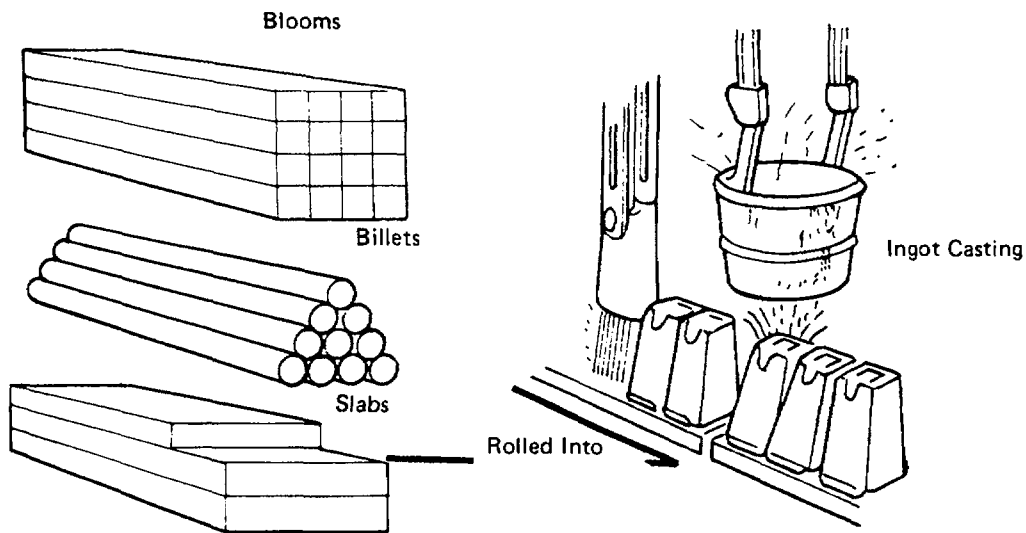

Figure 1.16. Typical primary material processes.

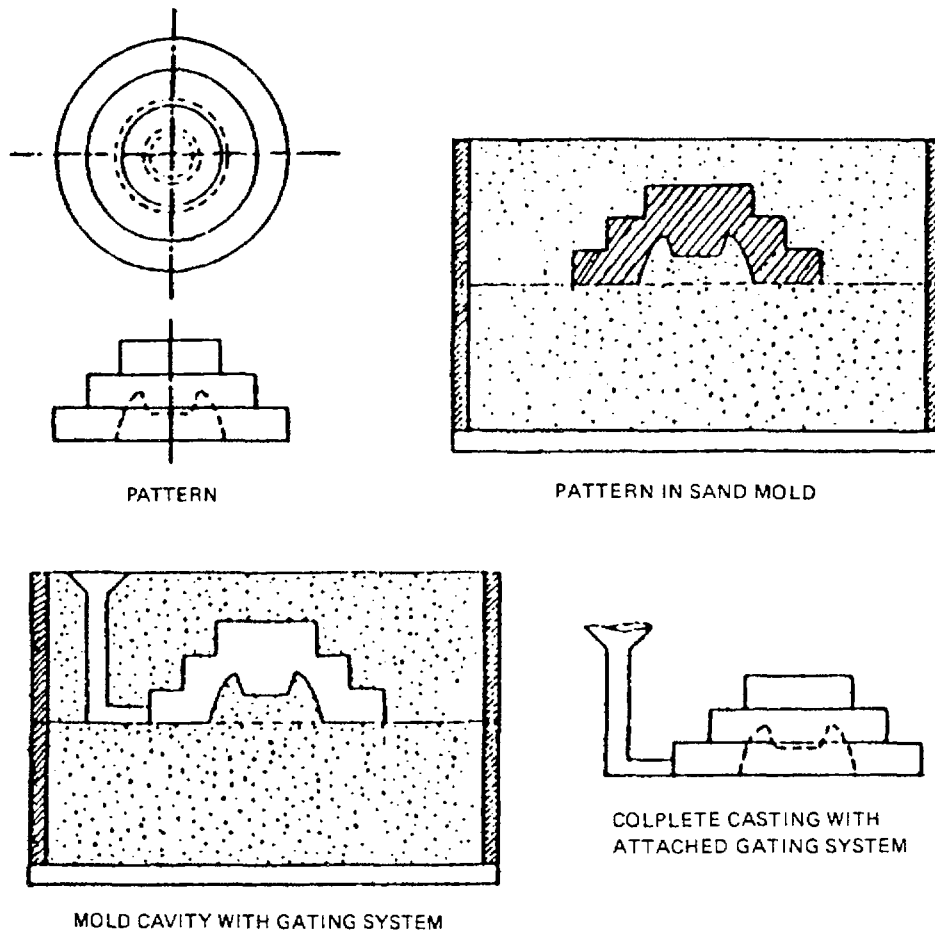

Figure 1.17: Casting steps.

Different types of sand moulds can be made for making different castings. Green sand moulds are made from moist sand and are used for practically all ferrous and non-ferrous castings. They have the disadvantage of not being very strong as well as requiring moisture during manufacture which may cause certain defects in the casting. Green sand moulds may be provided with a dry sand on the surface to give skin-dry moulds. Purely dry-sand moulds can also be made by adding to the sand a binder instead of moisture.

Methods of preparing sand moulds include bench moulding, machine moulding, floor moulding' and pit moulding. Bench moulding is used for small castings. This is usually a slow and laborious process since hand ramming with loose pattern is usually used. Small and medium moulds may be made even with the aid of a variety of machines which are usually faster and more uniform than bench moulding. Medium to large moulds are made directly on the foundry floor. Very large moulds made in a pit constructed for the purpose are called pit moulds.

The sands most commonly used in sand die casting contain silica sand which is usually from 50 to 95% of the total material in any moulding sand, zirconate and olivine, etc. The most important properties and characteristics of such sands are permeability, cohesiveness and refractoriness. Permeability is a condition of porosity and is related to the passage of gaseous material through the sand as well as to the density of sand grains. Cohesiveness can be defined as the holding together of sand grains or strength of moulding sand and depends upon the size and shape of the sand grains. The property of cohesiveness may be improved by adding to the sand some binders such as clay, resins and gums and drying oil. The third important characteristic of the moulding sand is refractoriness which is its ability to withstand a high temperature without

fusing. Pure silica sand can withstand a temperature as high as 3148°F. The property of refractoriness can be affected by impurities like metallic oxides.

Mould cavities may be produced by packing the moulding material around what are called patterns. The patterns may be made from wood, metal or other suitable materials. There are a variety of these patterns used in the manufacture of castings. Another important part of the casting process is the core box which is a structure made of wood, metal or other suitable material, containing a cavity with the shape of a desired core. Making a sand mould involves the proper packing of moulding sand around a pattern. After the pattern is removed from the sand and the gating arrangement completed, the mould cavity is filled with molten metal to form the casting.

Permanent mould casting

A casting made by pouring molten metal into a mould made of some metallic alloy or other material of permanence is known as a permanent mould casting.

Grey cast iron and meehanite with large graphite flakes are the most commonly used materials in the construction of permanent moulds. This common use is partly due to the ease with which they may be machined. Certain steels, particularly special alloy steels that are heat-treated, often have especially good resistance to erosion. They have excellent refractory properties. Some aluminium alloys on which the surface has been anodized, are also used as moulding materials. Anodizing produces Al_2O_3 which is very refractory and resistant to abrasion. These alloys are very easy to machine and possess a good chilling capacity. The mould is not destroyed on removing the casting and therefore can be re-used many times.

Die casting

Die casting may be defined as the use of a permanent mould (die) into which molten metal is introduced by means of pressure. The term pressure die casting is another name for this method of casting. This pressure is obtained by application of compressed air or by pneumatically or hydraulically operated pistons. This process of casting can be subdivided in two types.

- (a) Hot chamber die casting.
- (b) Cold chamber die casting.
- (a) Hot chamber die casting.

The melting unit is an integral part of the hot chamber machine, and molten metal is introduced directly from this melting unit, by means of plunger mechanism into the die cavity. The process is further characterized by a normal amount of superheat in the metal and the need for a commensurately lower casting pressure. Pressure on the molten metal in hot chamber die casting machines may vary from approximately 500 to 6000 psi (3.5 to 41 MPa). An average of approximately 2000 to 2500 psi (14 to 17 MPa) is common. Air injection pressures are normally limited to about 600 psi (4 MPa) Figure 1.18.

(b) Cold chamber die casting

The melting unit is usually separate in this case, and molten metal must be transferred to the injection mechanism by ladle Figure 1.19. Further distinctive characteristics of the process are, very high metal pressures and the fact that the casting alloy may be at a temperature somewhat less than normal superheat; the melt may even be in a semimolten condition. Pressure on the casting metal in cold chamber die casting machines may vary from 3000 psi (20.5 MPa) to as high as 25 000 psi (172 MPa) and in some cases may reach 100 000 psi (690 MPa). Metallic alloys cast in a semimolten condition require greater pressure to compensate for the reduced

fluidity resulting from low pouring temperatures. Lower working temperature and high pressures produce castings of dense structure, free of blow holes and porosity related to dissolved gases.

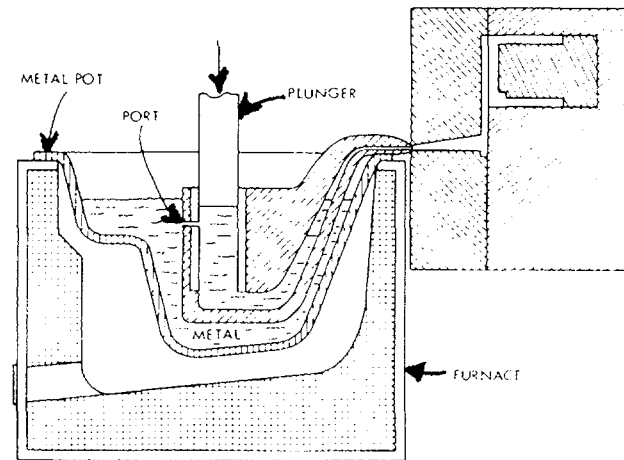

Figure 1.18: Hot chamber die casting.

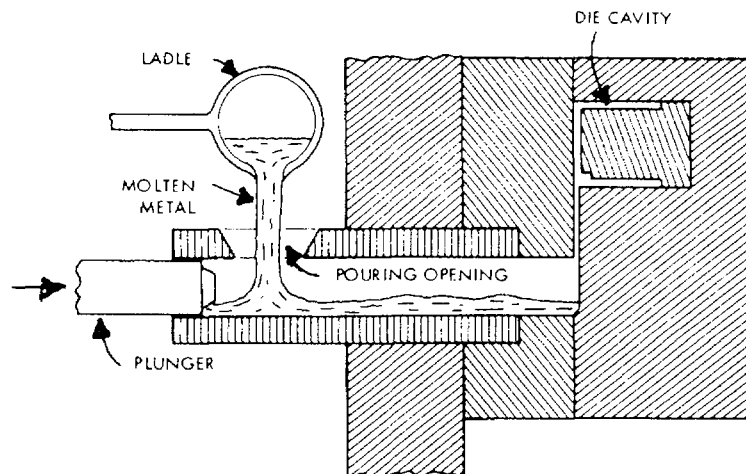

Figure 1.19: Cold chamber die casting.

Centrifugal casting

Any process in which molten metal is poured and allowed to solidify while the mould is revolving, is a centrifugal casting process. Castings produced under this centrifugal force are called centrifugal castings. There are three recognized centrifugal processes namely true centrifugal casting, semicentrifugal or profiled-centrifugal casting and centrifuged or pressure casting and are shown in Figure 1.20. True centrifugal casting is that in which castings are made in a hollow, cylindrical mould rotated about an axis common to both casting and mould. Cast-iron pipe is commonly made by this method. In this process the axis of spin may be horizontal, inclined, or vertical. In the true centrifugal casting process the inside circumference is always circular. When the mould is rotated on a horizontal axis, a true cylindrical inside surface is produced. True centrifugal casting is used only on symmetrically shaped objects. Semicentrifugal or profiled-centrifugal casting is similar to the true centrifugal method, except that a central core is used to form the inner surface or surfaces. The casting is not dependent upon centrifugal force

for its shape. A good example of semicentrifugal work is a cast wheel-like casting. The axis of spin in the semicentrifugal process is always vertical. Although the yield is better than with static casting, it is not as high as in true centrifugal casting. With this process also only symmetrically shaped objects can be cast.

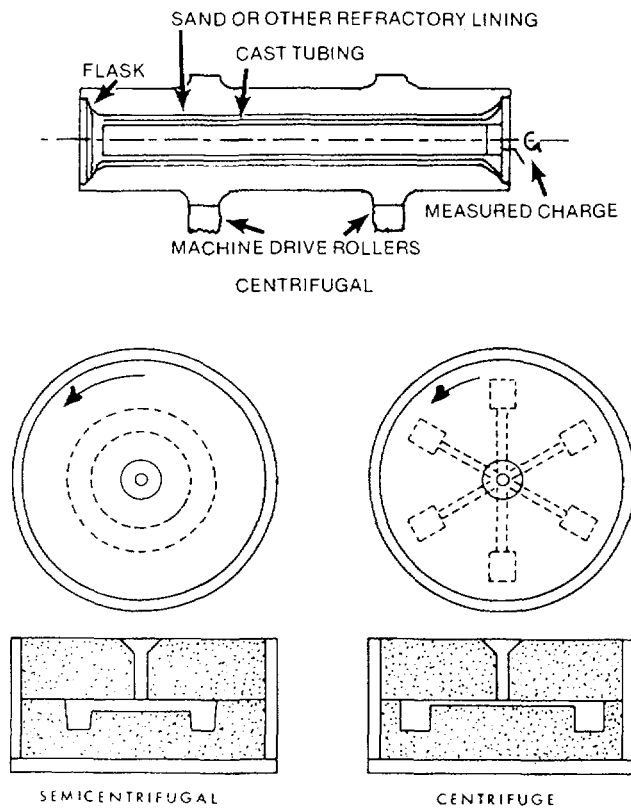

Figure 1.20: Centrifugal casting.

Centrifugal or pressure casting is applied for non-symmetrical castings. The mould cavity is not rotated about its own axis but about the axis of a central down sprue common to the axis of spin, which feeds metal into the mould cavity under centrifugal force. This process of centrifuging can be done only about a vertical axis. Centrifugal force provides a high pressure to force the metal alloy into the mould cavity.

Centrifugal casting processes can be used to produce parts made of both the ferrous and non-ferrous alloy groups. Cast-iron pipe, gun barrels, automotive cylinder walls, jet engine rings, piston rings and brake drums are common parts centrifugally cast. Advantages include the elimination of foreign inclusions and the production of sounder castings. The chief disadvantages are the shape and size limitations.

Investment casting

This process involves making a one-piece mould from which the pattern is removed by a procedure which melts the pattern. The moulds used in this process are single purpose moulds. The elimination of all parting planes provides improved dimensional tolerances. Since the pattern is removed by melting or burning out, casting precision is increased through eliminating draft, rapping, and shifts. Various other names are given to this process. It is also called precision investment casting, precision casting or the lost-wax process and is shown in Figure 1.21.

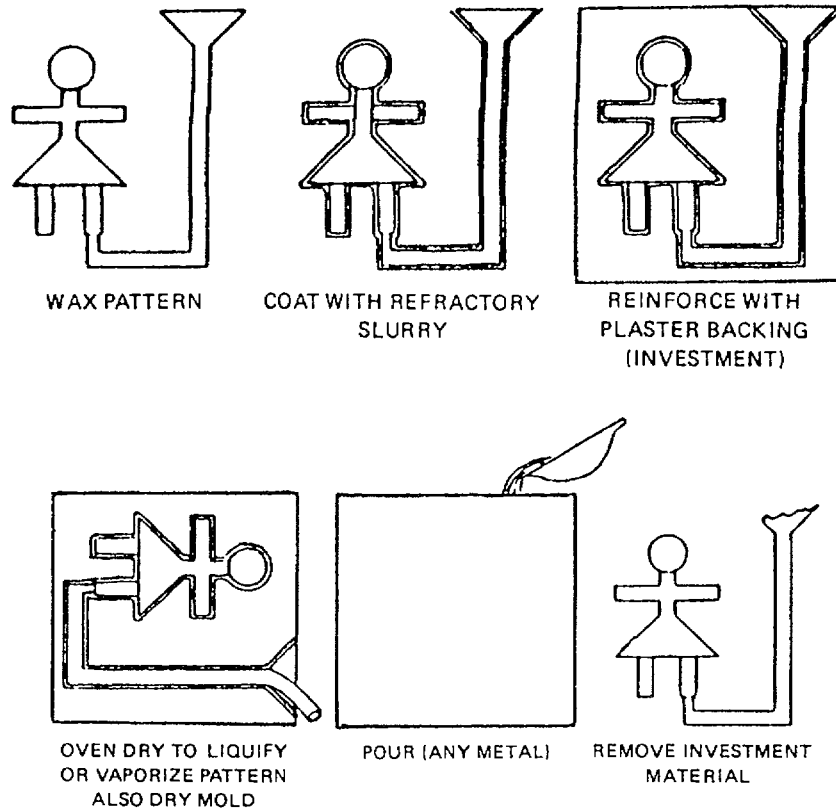

Figure 1.21: Steps for investment casting.

Various types and grades of wax are the common materials for pattern making for investment casting. Certain plastics that burn without residue are also used as pattern materials. Some low melting point metallic alloys can also be used as pattern materials. In this process of casting the patterns are formed afresh each time by casting or forging the pattern material in dies made of metal, plastic, rubber or wood.

Patterns are first made of wax or other pattern materials by melting and then injecting it into a metallic or non-metallic die. Then the patterns are welded or joined to gates and runners, which are also of the same material as the pattern. By this welding or joining of the pattern to gates and runners a tree like pattern is prepared. This tree is now dipped into a refractory sand, placed in a metal flask and sealed to the pallet. Then the investment or moulding material, in viscous slurry form, is poured around the pre-coated tree. When the investment has set, the mould is heated by putting it in an oven at 200°F. By this heating the mould is dried and baked and the pattern is melted and the molten pattern material is taken out of the mould. Now as a final touch to the mould before casting, the mould is placed in a furnace and is heated to a temperature of 1300–1900°F. This removes all the wax residue, if any, sticking to the investment mould. The mould is then heated to the casting temperature.

Shell mould casting

This process involves making a mould that has two or more thin, shell-like parts consisting of thermosetting resin-bonded sand. These shells are single purpose in application and are hard and easily handled and stored. Shells are made so that matching parts fit together easily, held with clamps or adhesives and poured in either a vertical or horizontal position. These moulds may be supported in racks or in a mass of bulky permeable material like sand, steel shots, or gravel.

Metallic patterns are used for the production of shells, as they are subjected to heating temperatures approaching 1,000°F. The pattern must have some provision, in the form of ejector pins, for the removal of shells from the surface of the pattern. Clean dry silica sand is the bulk material used in the making of shell moulds. Grain size and distribution can vary with use. Thermosetting synthetic resins are used as binders for sand. The resins include the phenolformaldehydes, urea formaldehydes, and others.

The sand and resin mix or coated sand is caused to fall against, or is blown against, a heated metal pattern or core box. The temperature of the pattern ranges from 350 to 600°F. Contact of the thermosetting resin with the hot pattern causes an initial set and thus an adhering layer of bonded sand is formed within 5 to 20 seconds. The pattern with this adhering layer of bonded sand is placed into the furnace and is cured by heating to the proper temperature for one to three minutes. The time of curing depends on the shell thickness and the resin type. The assembly is then removed from the furnace and the shell is stripped from the pattern by ejector devices. This stripping is sometimes a problem and can be overcome by using a silicon parting agent.

The main advantages of this process are that the 'shell' cast parts have generally a smooth surface and thereby reduce machining costs. These techniques are readily adaptable to mass production by using automatic equipment. The disadvantages can be the initial cost of metal patterns, the higher cost of the resin binders and a general size limitation.

Continuous casting

Although only a small tonnage of castings are produced by continuous casting, it is possible to produce two dimensional shapes in an elongated bar by drawing solidified metal from a water-cooled mould. As shown schematically in Figure 1.22 molten metal enters one end of the mould, and solid metal is drawn from the other. Control of the mould temperature and the speed of drawing is essential for satisfactory results. Exclusion of contact with oxygen, while molten and during solidification, produces high quality metal. Gears and other shapes in small sizes can be cast in bar form and later sliced into multiple parts.

Casting defects

There are in general three broad categories of casting defects. First are the major or most severe defects which result in scraping or rejection of the casting. The second category is of intermediate defects which permit salvaging of the casting through necessary repair. The third category defects are minor ones which can be easily repaired. The elimination and control of casting defects is a problem that the foundry engineer may approach in several ways.

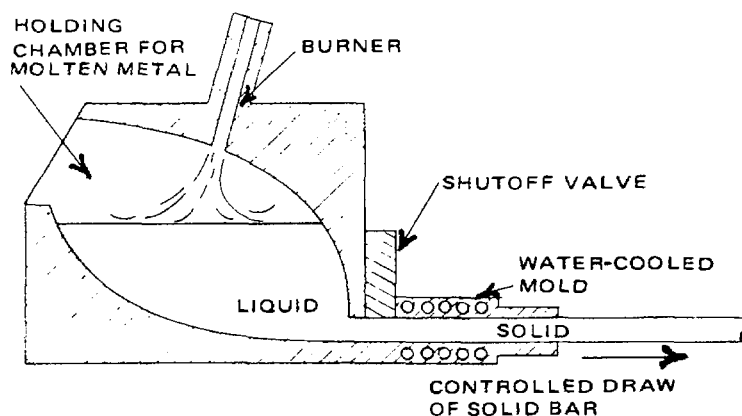

Figure 1.22: Schematic diagram of continuous casting process.

TABLE 1.2. COMPARISON OF CASTING METHODS (APPROXIMATE)

	Sand casting	Permanent mould casting	Die-casting	Centrifugal casting	Investment casting	Shell mould casting
Relative cost in large quantity	Medium	Low	Lowest	High	Highest	Medium
Relative cost for small number	Lowest	High	Highest	Medium	Low	Low
Permissible weight of casting	Unlimited	100 lb	300 lb	Several tons	5 lb	Limited
Thinnest section castable(mm)	3.25	3.25	01	12.50	0.25	3.25
Typical dimensional tolerance (mm)	1.60	0.75	0.25	1.60	0.25	0.25
Relative surface finish	Poor	Good	Best	Fair	Very good	Good
Relative mechanical properties	Fair	Good	Very good	Best	Fair	Good
Relative ease of casting complex designs	Fair	Fair	Good	Poor	Best	Fair
Relative ease of changing design in production	Best	Poor	Poorest	Good	Good	Good
Range of alloys that can be cast	Unlimited	Copper base and lower melting preferable	Aluminium base and lower melting preferable	Unlimited	Unlimited	Unlimited

The common procedure is to rely upon salvaging techniques that appear to provide immediate savings. Remedial procedure in the moulding, coremaking, melting or pouring areas of the foundry are frequently neglected but are highly desirable to be controlled to avoid defects. Some of the defects which usually occur in castings are given hereunder:

Porosity

Gas holes are spherical holes of varying size, with bright walls, usually fairly evenly distributed and formed by gas in the metal. The larger holes tend to be found in the heavier section (i.e. last to solidify). If the metal is correct prior to casting, the pinhole type of porosity is probably due to absorption of hydrogen from steam in the mould. The gas in the molten metal is removed by a gas scavenging technique and by keeping casting ladles and moulds dry.

Blowholes

Blowholes are mainly found in three forms: i) Elongated cavities with smooth walls, found on or just below the surface of the topmost part of a casting. These are caused by entrapped air and repetition can be avoided by venting the mould and increasing its permeability. ii) Rounded

shape cavities with smooth bright walls are caused by mould or core gases, coupled with insufficient permeability, or venting. They can be avoided by using less oil binder in the mould and ensuring that cores are dry and properly baked and that the sand is properly mixed. iii) Small cavities immediately below the 'skin' of the casting surface are formed by the reaction of the molten metal with moisture in the moulding sand. This can be avoided by reducing the volatile content in mould cores and mould dressing, by ensuring that metal is deoxidized, by using more permeable sands, by ensuring that moulds and cores are properly vented and by reducing pouring temperature.

Piping

When this term is used in the foundry it refers to the gas inclusion defects encountered in risers or within the casting proper.

Inclusions

These are material discontinuities formed by the inclusion of oxides, dross, and slag in a casting. They are due to careless skimming and pouring, or the use of a dirty ladle, and to turbulence due to improper gating methods when casting alloys, such as aluminium and bronze, that are subject to surface oxide-skin formation. Faulty closing of moulds can cause 'crush' and loose pieces of sand becoming incorporated in the casting. The occurrence of inclusions can be avoided by proper use of equipment and foundry practice.

Sponginess

A defect that occurs during the early stages of solidification of a casting and has the appearance, as the name would imply, of a sponge; it may be local or general in extent. The major cause is failure to obtain directional solidification of the casting towards the desired heat centres, such as risers and ingates; insufficiently high pouring temperature and placing of ingates adjacent to heavy sections.

Shrinkage

A casting defect that occurs during the middle and later stages of solidification of the cast metal. It has a branching formation, is readily distinguishable from that of sponginess, and is a form of void Figure 1.23. The defect can be avoided by paying particular attention to the direction of solidification and ensuring adequate risers, or other feeding aids, on the heavier sections of a casting. Modification of casting design, i.e. to make cast sections more uniform for the flow and solidification of the metal is helpful in avoiding shrinkage. Moulds and cores are sometimes made too strong and greatly resist the contraction of the cast metal and, in this way, will cause a breakdown in the homogeneity of the metal.

Hot tears

These are discontinuities that result from stresses developed close to the solidification temperature while the metal is still weak. These, again, are attributed to resistance of the mould and core, which hinder contraction of the casting, causing thermal stress. Hot tears resemble ragged cracks. They can be avoided by making cores and moulds more collapsible, avoiding abrupt changes in section and preventing the formation of intense hot spots by designing with more uniform sections Figure 1.24.

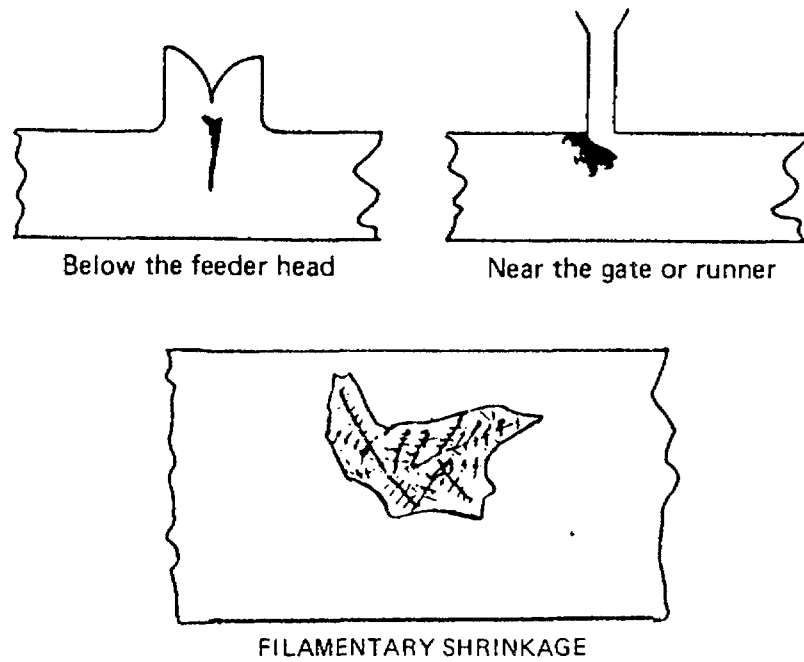

Figure 1.23: Formation of shrinkage defects.

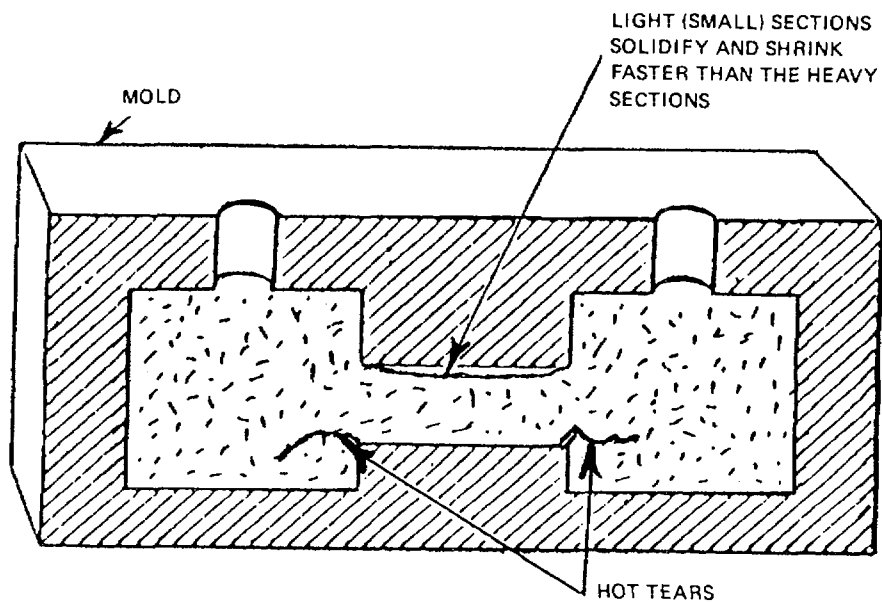

Figure 1.24: Hot tears.

Crack

Well defined and normally straight, they are formed after the metal has become completely solid. Quite large stresses are required to cause fracture, and the walls of such cracks are discoloured according to the temperature of the casting when the cracks formed. Bad casting design coupled with restriction of contraction by the mould, core, or box bars contribute to

cracking, and avoidance of these, together with the easing of mould or cores as soon as possible after solidification, will help to prevent build-up of stresses.

Cold shuts

These are discontinuities (a form of lack of fusion) caused by the failure of a stream of molten metal to unite with another stream of metal, or with a solid metal section such as a chaplet Figure 1.25. They are linear in appearance, with perhaps a curling effect at the ends. A cold shut is caused by the fluidity of the metal being too low (i.e. surfaces too cold) or perhaps unsatisfactory methods of feeding the molten metal.

Cold shuts can often be avoided by raising the pouring temperature or pouring rate or both and reviewing the position, size, and number of ingates and the arrangements for venting the mould.

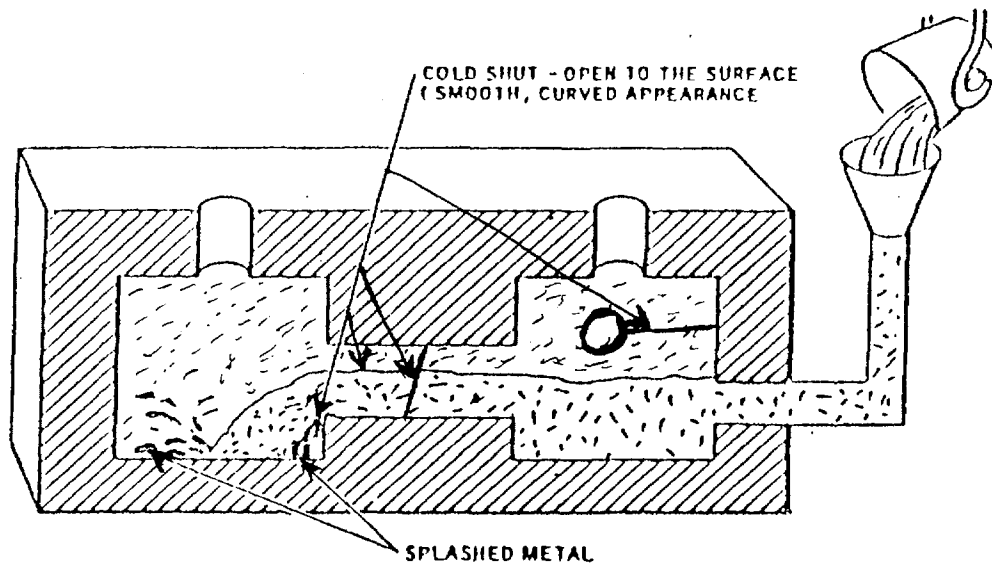

Figure 1.25: Types of cold shuts.

Unfused chaplet

A chaplet is often used to support a section of a mould or a core within a mould and when the molten metal is poured in, the chaplets should fuse into the casting. When unfused the chaplet will cause a discontinuity in the casting. Design of chaplet and type of chaplet should be reviewed in overcoming this defect.

Misplaced core

An irregularity of wall thickness, e.g. one wall thicker than the other, can be detected by a double wall technique radiograph. It is caused by core out-of-alignment, careless coring-up and closing of mould, or rough handling after the mould is closed.

Segregation

Segregation is a condition resulting from the local concentration of any of the constituents of an alloy. The segregation can be general extending over a considerable part of a casting, local

when only the shrinkage voids or hot tears are wholly or partially filled with a constituent of low melting point or 'banded' which is mainly associated with centrifugal castings but can also occasionally occur in static castings.

Powder metallurgy processes

The definition for the term powder metallurgy is 'the art of producing metal powders and objects shaped from individual, mixed, or alloyed metal powders, with or without the inclusion of non-metallic constituents, by pressing or moulding objects which may be simultaneously or subsequently heated to produce a coherent mass, either without fusion or with the fusion of a low melting constituent only'. Figure 1.26 shows the steps ordinarily required in the production of a part by the powder metallurgy process. Suitable powder must first be produced. While theoretically any crystalline material may be fabricated by powder metallurgy, the production of suitable powder has presented restrictions in many cases, either because of difficulty in obtaining adequate purity or because of economic reasons. After selection and blending of the powder and manufacture of a die for the shape to be produced, the powder is pressed to size and shape. The application of heat results in crystalline growth and the production of a homogeneous body.

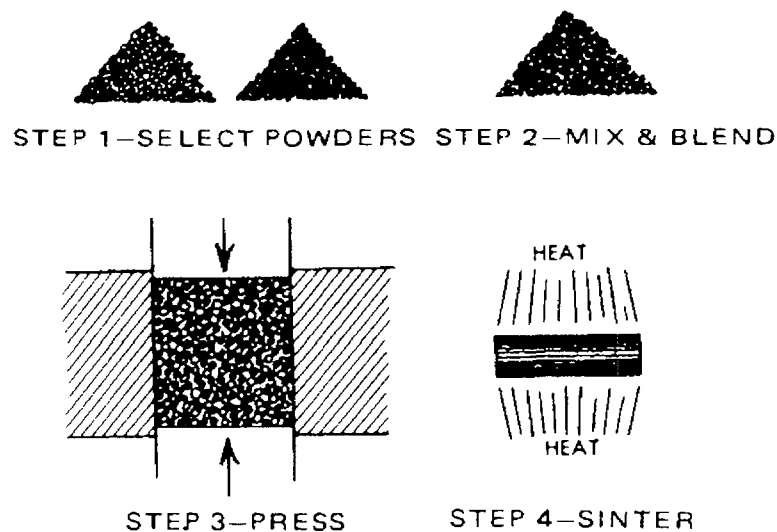

Figure 1.26: Elements of powder metallurgy.

Mixing and blending

Mixing is required for even a single metal powder to promote homogeneity with a random dispersion of particle sizes and shapes. The mixing and blending is even more important for combinations of materials that depend on uniform alloying to develop final properties. Small amounts of organic materials may be added to reduce segregation, and other materials, both organic and inorganic, may be added to act as lubricants during pressing or sometimes in the final product.

Pressing

Compacting of metallic powders ideally would be done by applying pressure in all directions at one time. This is usually impractical for commercial use, and most compaction is

done along a single axis. Pressure is sometimes applied from one direction only, but in other cases opposing motions are used to reduce the effect of sidewall friction. The effectiveness of pressing is most often evaluated by measuring the density of the material and expressing it as a percentage of the theoretical density for solid metal of the type being treated. Densities depend on the particle size and shape, the material, the pressure, the time, and the temperature. The density variation problem is further complicated by shapes that are other than simple cylinders. Development of pressure by centrifuging may produce more uniform density because each particle of material supplies a force of its own.

Sintering

The term sintering is used to identify the mechanism by which solid particles are bonded by application of pressure or heat, or both. In its broadest sense, the process includes such procedures as welding, brazing, soldering, firing of ceramics, and union of plastic flakes or granules. Each of the procedures other than those involving metal in powder form are important enough and of such wide usage as to have developed their own language and technology. Sintering can be accomplished at room temperature with pressure alone but it is most often performed at elevated temperature, either at the same time or after pressure has been applied. The two most common sintering procedures are: (1) application of heat and pressure together, called hot pressing; and (2) application of heat after the particles have been closely packed, by cold pressing. In hot pressing, the plasticity of the particles is greater, and they recrystallize more readily and thus permit high densities to be achieved with lower pressures than would be necessary at lower temperatures. Cold-pressed parts that are subsequently sintered may be heated in conventional manner by being placed in ordinary furnaces or salt baths.

Deformation

Because of variations of density and other factors, shrinkage of powder metallurgy products during sintering is difficult to control. Parts that require close tolerances must nearly always be finished by some dimensional treatment. Cold working may be used for minor changes of dimensions, but this procedure is limited by the lack of ductility common to powder metallurgy products. Repressing, sometimes referred to as coining, improves the density, strength, and ductility of the material. Even with this process, it is seldom that these properties are equal to those of a similar material produced by fusion. Most commercial deformation working is done by hot working or by cold working with frequent interruptions for recrystallization.

Heat treatment

Powder metallurgy products may be heat treated in the same ways as other materials of similar chemical composition, but the treatments are usually not as effective as for the fusion produced metals, mainly because of the porous structure restricting the heat conductivity. *Many of the voids within powder metallurgy products are stress concentration points that not only limit service loads but also increase the stresses arising from thermal gradients during heat treatment.* The treatments include resintering for stabilization and homogeneity, annealing for softness, grain refinement for improved ductility, and hardening for improved wear resistance.

Machining

The machinability of sintered materials is usually poor, but machining is sometimes necessary to provide final control of dimensions or to establish shapes that are not practical for the powder metallurgy process. With some types of products, such as the cemented carbides, grinding is the common finishing process both to control size and shape and, in many cases, to eliminate the surface produced in the sintering process.

Impregnation

One important finishing step is that of impregnation. Inorganic materials, such as oils or waxes, may be impregnated into porous metal products for purposes of lubrication. An entirely different kind of product can be produced by impregnating high melting temperature metals with low melting temperature metals. The principal use of this technique is in the production of cemented steels.

Applications of powdered metal products

Powder metallurgy occupies two rather distinct areas. It is a basic shape-producing method for practically all metals, in direct competition with other methods. In addition, for many refractory materials, both metals and non-metals, powder metallurgy is the only practical means of shape production. Tungsten is typical of the refractory metals; it has a melting point of 3400°C, and no satisfactory mould or crucible materials exist for using conventional casting techniques at this temperature. Tantalum and molybdenum are similar.

Cemented carbides form one of the most important groups of materials that can be fabricated into solid shapes by powder metallurgy only. The biggest use is for cutting tools and cutting tool tips or inserts, but the cemented carbides are also used for small dies and some applications where wear resistance is important. The principal material used is tungsten carbide, although titanium carbide and tantalum carbide are also used. Some very useful production cutting tools are manufactured by using strong, tough materials as a core and impregnating the surface with titanium carbide or another hard, wear resistant material.

A further area in which powder metallurgy produces products not practical by other means is the manufacture of materials with controlled low density. One of the first mass-produced powder metallurgy products was sintered porous bronze bearings. After cold pressing, sintering, and sizing, the bearings are impregnated with oil, which in service is made available for lubrication. Although not true fluid film bearings, they provide long service with low maintenance. Porous materials are also useful as filters.

Composite electrical materials form a group similar to the cemented carbides. Tungsten and other refractory metals in combination with silver, nickel, graphite, or copper find wide applications as electrical contacts and commutator brushes; powder metallurgy not only provides a means for producing the combination but also provides the finished shape for the parts. Many of the currently used permanent magnetic materials are as well produced by powder metallurgy.

1.3.2. Manufacturing processes and related defects

Welding processes

Welding can be defined as the metallurgical method of joining, applied to the general problem of construction and fabrication. It consists of joining two pieces of metal by establishing a metallurgical atom-to-atom bond, as distinguished from a joint held together by friction or mechanical interlocking. This metallurgical atom-to-atom bond is achieved by the application of heat and sometimes pressure.

Many welding processes require the application of heat or pressure, or both, to produce a suitable bond between the parts being joined. The physics of welding deals with the complex physical phenomena associated with welding, including heat, electricity, magnetism, light, and sound. In making a joint two parts of the same chemical composition may be welded together using no added metal to accomplish the joint. This might be termed as autogenous welding. A metal which is of the same composition as the parts being joined may be added, in which event,

the process would come under the general heading 'homogenous' welding. Finally, an alloy quite different from that of which the parts are made may be used or alternatively the parts themselves may differ significantly in composition. Then this process is called heterogeneous welding. Almost every imaginable high energy density heat source has been used at one time or another in welding. Externally applied heat sources of importance include arcs, electron beams, light beams (lasers), exothermic reactions (oxyfuel gas and thermit), and electrical resistance. Welding processes that acquire heat from external sources are usually identified with the type of heat source employed. The welding processes which are commonly used for the welding of metals are described and their features are discussed in the following sections.

Weld design and positions

The loads in a welded structure are transferred from one member to another through welds placed in the joints. The types of joints used in welded construction and the applicable welds are shown in Figure 1.27.

All welds that are encountered in actual construction, except groove welds in pipe, are classified as being flat, horizontal, vertical, or overhead. Groove welds in pipe are classified as horizontal rolled, horizontal fixed, vertical, or inclined fixed. These positions are illustrated in Figures 1.28 and 1.29 and explained below:

- Flat position (1G). The test plates are placed in an approximately horizontal plane and the weld metal deposited from the upper side Figure 1.28 (A).
- Horizontal position (2G). The test plates are placed in an approximately vertical plane with the welding groove approximately horizontal Figure 1.28 (B).
- Vertical position (3G). The test plates are placed in an approximately vertical plane with the welding groove approximately vertical Figure 1.28 (C).
- Overhead position (4G). The test plates are placed in an approximately horizontal plane and the weld metal deposited from the underside Figure 1.28 (D).
- Horizontal rolled (1G). The pipe is placed with its axis in an approximately horizontal plane with the welding groove in an approximately vertical plane and the pipe is rolled during welding Figure 1.28 (A).
- Vertical (2G). The pipe is placed with its axis in an approximately vertical position with the welding groove in an approximately horizontal plane Figure 1.28 (B).
- Horizontal fixed (5G). The pipe is placed with its axis in an approximately horizontal plane with the welding groove in an approximately vertical plane and the pipe is not to be rolled or turned during welding Figure 1.28 (E).
- Inclined fixed (6G). The pipe is inclined fixed ($45^\circ \pm 5^\circ$) and not rotating during welding Figure 1.28 (F).
- For fillet welds in plates, different positions are defined as below:
 - Flat position (1F). The test plates are so placed that each fillet weld is deposited with its axis approximately horizontal and its throat approximately vertical Figure 1.29 (A).
 - Horizontal position (2F). The test plates are so placed that each fillet weld is deposited on the upper side of the horizontal surface and against the vertical surface Figure 1.29 (B).
 - Vertical position (3F). Each fillet weld is made vertically Figure 1.29 (C).
 - Overhead position (4F). The test plates are so placed that each fillet weld is deposited on the underside of the horizontal surface and against the vertical surface Figure 1.29 (D).

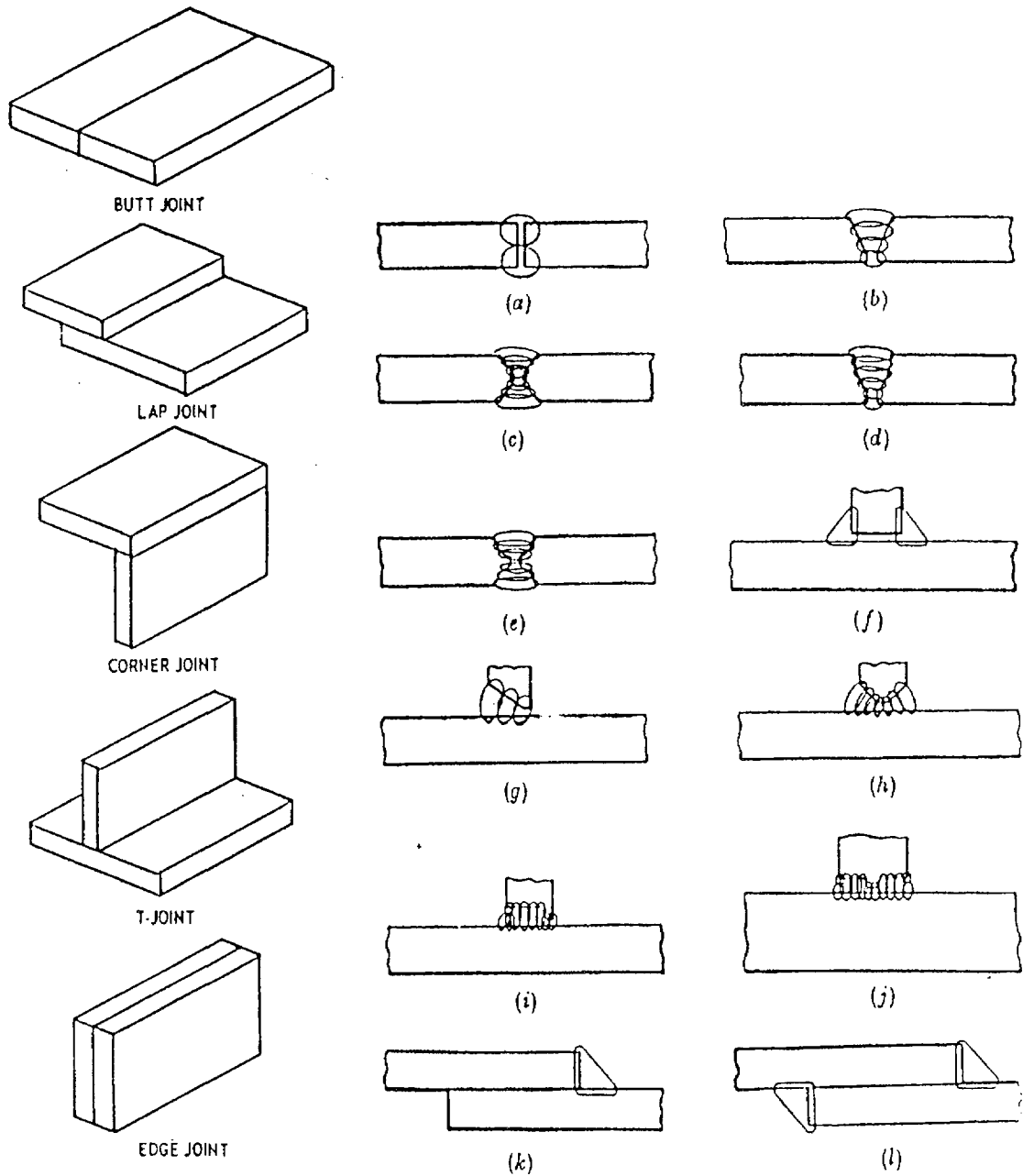
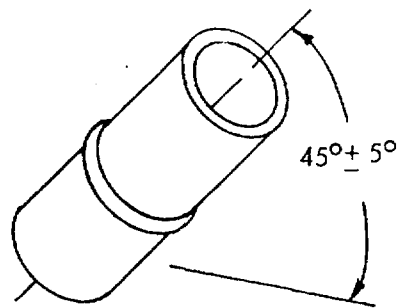
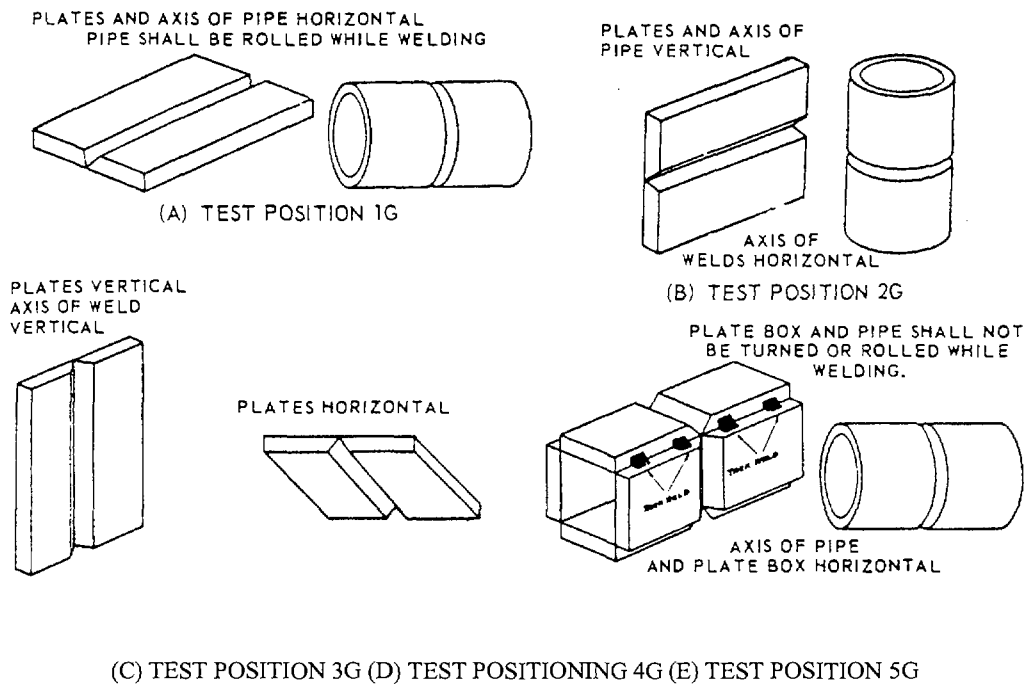

Figure 1.27: Types of Welding joints; (a) square butt joint, (b) single-v butt joint, (c) double-v butt joint, (d) single-u butt joint, (e) double-u butt joint, (f) square-t joint, (g) single-bevel t-joint, (h) double-bevel t-joint, (i) single-u t-joint, (j) double-u t-joint, (k) single-bead lap joint, (l) double-bead lap joint.



(F) TEST POSITION 6G

Figure 1.28: Positions of plates and pipes for groove weld.

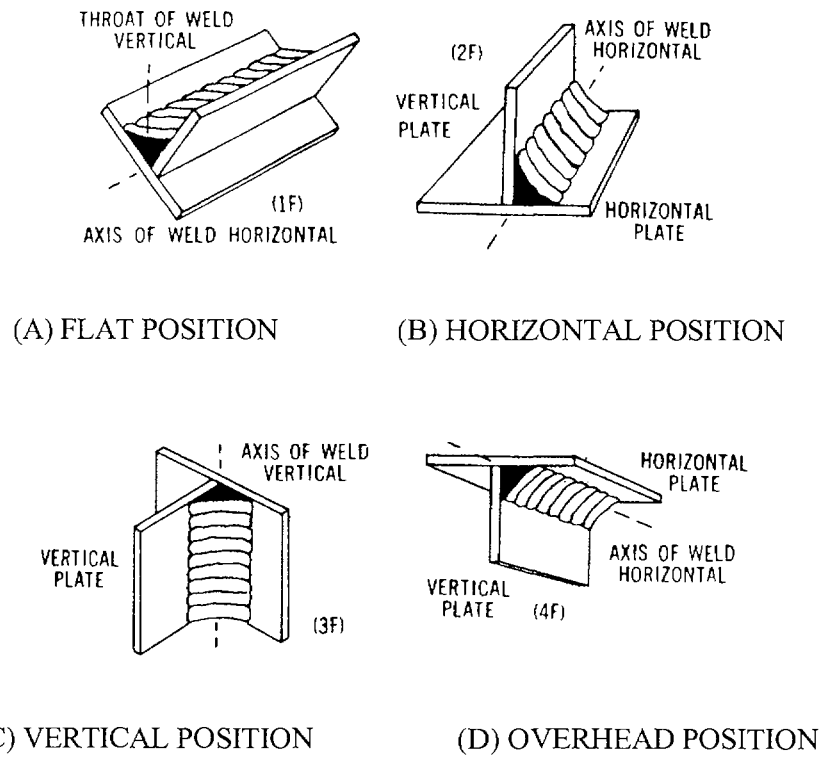

Figure 1.29: Positions of plates for fillet welds.

Shielded metal arc welding (SMAW)

Shielded metal arc welding is an early arc welding process. It is one of the simple and versatile processes for welding ferrous and several non-ferrous base metals. Basically, it is a manual welding process in which the heat for welding is generated by an arc established between a flux covered consumable electrode and the work. The electrode tip, welded puddle, arc and adjacent areas of the work piece are protected from atmospheric contamination by a gaseous shield obtained from the combustion and decomposition of the flux covering. The process is illustrated in Figure 1.30.

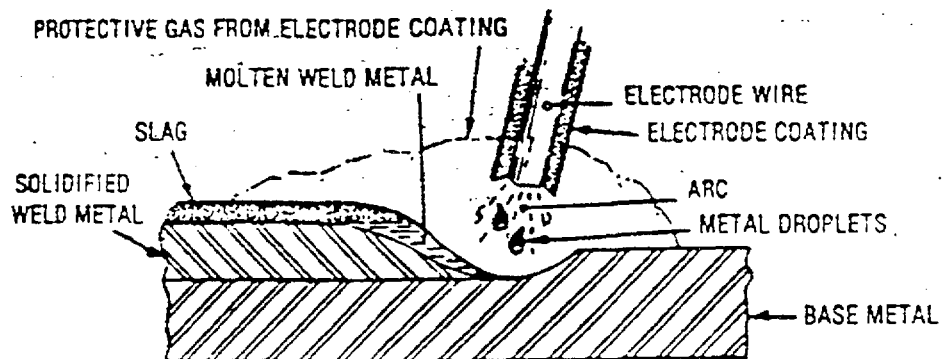

Figure 1.30: Shielded metal arc welding process.

Covered electrodes are produced in a variety of diameters normally ranging from 1/16 to 5/16 in. (2 to 8 mm). The smaller diameters are used with low currents for joining thin sections and for welding in all positions. The large diameters are designed for conducting high currents to achieve greater deposition rates in the flat and horizontal positions. Special alloy filler metal compositions can be formulated with relative ease by the use of metal powders in the electrode coating.

The SMAW process has several advantages. Using the process, job shops can handle many welding applications with a relatively small variety of electrodes. Other advantages are the simplicity and lightness of the equipment, and its relatively low cost. Also, welds can be made in confined locations or remote from heavy power supplies.

Submerged arc welding (SAW)

In submerged arc welding the arc and molten metal are shielded by an envelope of molten flux and a layer of unfused granular flux particles as shown in Figure 1.31. When the arc is struck, the tip of the continuously fed electrode is submerged in the flux and the arc is therefore not visible. The weld is made without the intense radiation that characterizes an open arc process and with little fumes.

The SAW process is used in both mechanized and semiautomatic operations, although the former is by far more common. High welding currents can be employed to produce high metal deposition rates at substantial cost savings. Welds can only be made in the flat and horizontal positions.

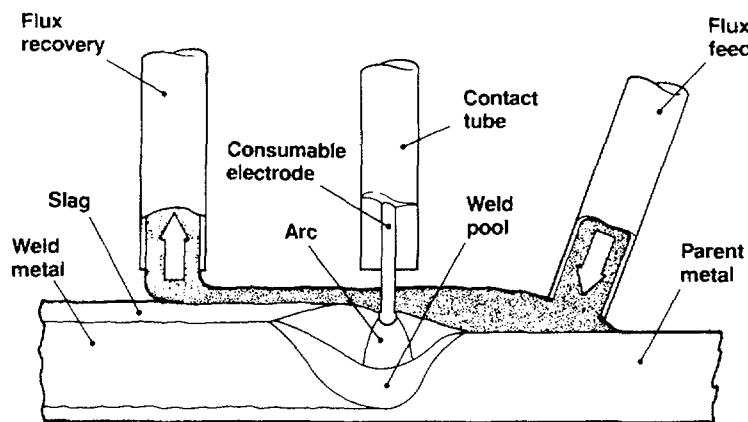

Figure 1.31: Submerged arc welding process.

The process is most widely employed for welding all grades of carbon, low alloy, and alloy steels. Stainless steel and some nickel alloys are also effectively welded or used as surfacing filler metals with the process. Various filler metal-flux combinations may be selected to provide specific weld metal properties for the intended service. The flux may contain ingredients that when melted react to contribute alloying additions to the weld metal.

Gas metal arc and flux cored arc welding (GMAW & FCAW)

Gas metal arc welding (GMAW/ or MIG/MAG) and flux cored arc welding (FCAW) are two distinct processes, but they have many similarities in application and equipment. Both processes use a continuous solid wire or tubular electrode to provide filler metal, and both use gas

to shield the arc and weld metal. In GMAW, the electrode is solid, and all of the shielding gas is (argon, helium, CO₂ or mixtures of these gases) supplied by an external source, as shown in Figure 1.32.

The original gas metal arc process consisted of a continuous operation requiring high current densities to achieve a smooth transfer of molten metal.

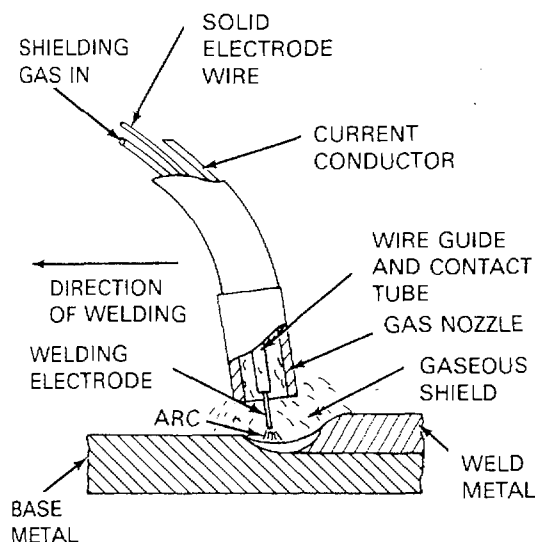

Figure 1.32: Gas metal arc welding process.

The process permits welding with minimal spatter, uniform penetration, and good out-of-position capability. With FCAW, the electrode is tubular and contains core ingredients that may supply some or all of the shielding gas needed. This process may also use auxiliary gas shielding, depending on the type of electrode employed, the material being welded, and the nature of the welding involved. FCAW is illustrated in Figure 1.33.

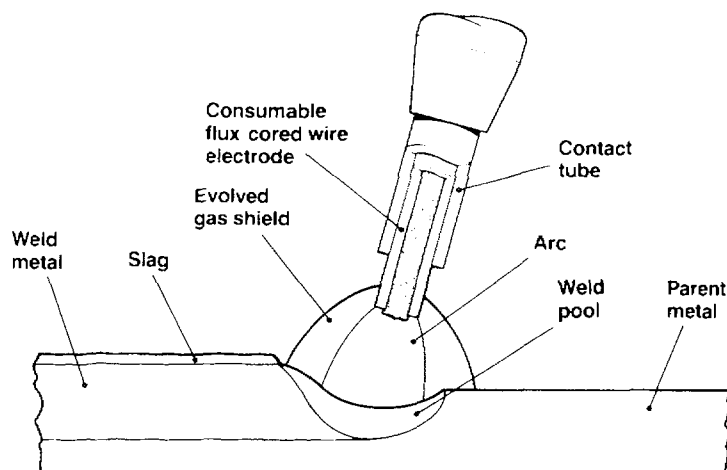

Figure 1.33: Flux cored arc welding.

Flux cored arc welding uses cored electrodes instead of solid electrodes for joining ferrous metals. The flux core may contain minerals, ferroalloys, and materials that provide shielding gases, deoxidizers, and slag forming materials. The additions to the core promote arc stability, enhance weld metal mechanical properties, and improve weld contour. Many cored electrodes are designed to be used with additional external shielding. Carbon dioxide-rich gases are the most common. Weld metal can be deposited at higher rates, and the welds can be larger and better contoured than those made with solid electrodes, regardless of the shielding gas.

Gas tungsten arc welding (GTAW)

Gas tungsten arc welding uses a non-consumable tungsten electrode which must be shielded with an inert gas. The arc is initiated between the tip of the electrode and work to melt the metal being welded, as well as the filler metal, when used. A gas shield protects the electrode and the molten weld pool, and provides the required arc characteristics. This process is illustrated in Figure 1.34 and is also sometimes called TIG welding.

Several types of tungsten electrodes are used with this process. Thoriated and zirconiated electrodes have better electron emission characteristics than pure tungsten, making them more suitable for dc operations.

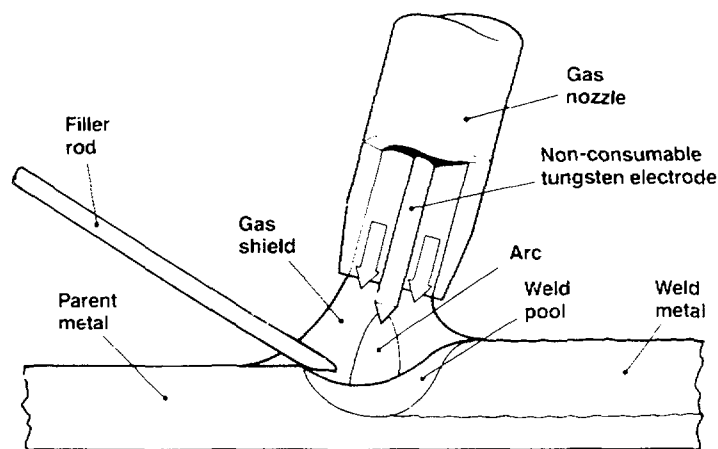

Figure 1.34: Gas tungsten arc welding.

Electro-slag welding (ESW)

Electroslag welding is a specialized adaptation of submerged arc welding and it is used for joining thick materials in the vertical position. This process is illustrated in Figure 1.35. Strictly speaking it is not an arc welding process at all, because it actually depends on the electrical receptivity of a molten flux bath to produce the heat necessary to melt the filler and base metal.

The process is, however, initiated by an arc, which heats a layer of granular welding flux contained within water cooled moulding shoes or dams and the edges of the joint, thus turning it to a bath of molten slag. The arc is then extinguished, and the conductive slag maintained in a molten condition by its resistance to the electric current passing through from a consumable electrode to the work. The principal application of electroslag welding is welding of thick steel plate heavy forgings and large steel castings in the fabrication of machine bases and in the structural steel industry. Its main features are: (i) Extremely high metal deposition rates, (ii) Ability to weld very thick materials in one pass, (iii) Minimal joint preparation and fit-up requirements, (iv) Little or no distortion and (v) Low flux consumption.

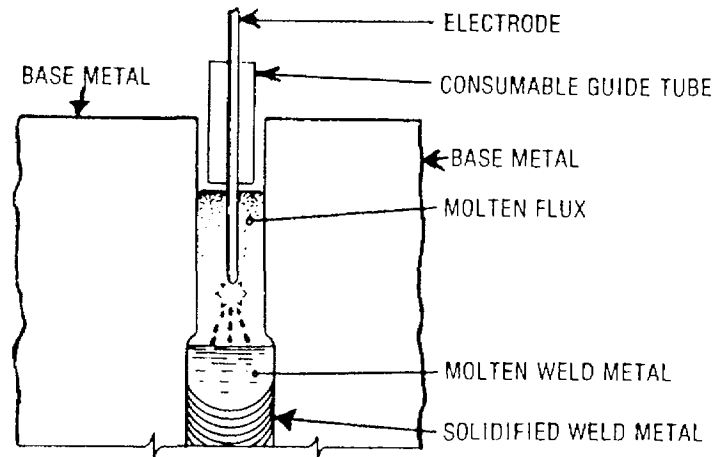

Figure 1.35: Electroslag welding process.

Stud arc welding (SAW)

In stud welding, basically an arc welding process, the welding arc is generated between a metal stud or similar part and the part to which it is ultimately fused by the welding heat so generated Figure 1.36. In a way it is also a variation of the shielded metal arc process, the stud representing the electrode. But only the end of the electrode is melted and it becomes a permanent part of the final assembly.

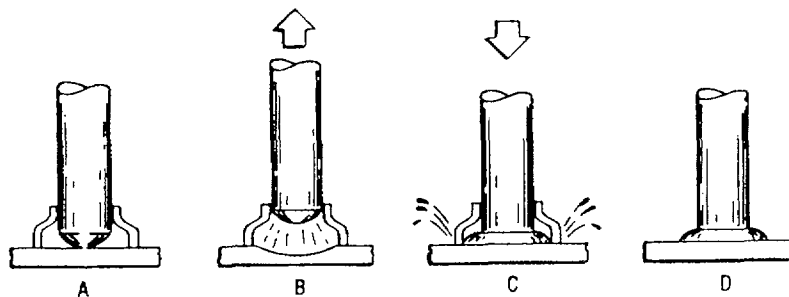

Figure 1.36: Stud welding sequence.

In operation the stud is retained in a hand held or bench mounted gun and is positioned over the spot where it is to be attached. Upon initiation, current flows through the stud, which, at the same time, is lifted slightly, creating an arc. After a very short arcing period, the stud is plunged into the molten pool created on the base plate, and the gun is withdrawn.

Typical applications of stud welding include securing special lining in tanks, studding boiler tubes, assembling electrical panels, securing water, hydraulic, and electrical lines to buildings, vehicles and large appliances, and securing feet and handles to large appliances.

Plasma arc welding (PAW)

The plasma arc welding process provides a very stable heat source for welding most metals from 0.001 to 0.25 in. (0.02 to 6 mm). This process has advantages over other open arc welding processes, such as SMAW, GMAW, and GTAW, because it has greater energy concentration, improved arc stability, higher heat content, and higher welding speeds. As a result, PAW has greater penetration capabilities than SMAW, GMAW, and GTAW.

The basic elements of the plasma arc torch, illustrated in Figure 1.37, are the tungsten electrode and the orifice. A small flow of argon is supplied through the orifice to form the arc plasma. Shielding of the arc and weld zone is provided by gas flowing through an encircling outer nozzle assembly. The shielding gas can be argon, helium, or mixtures of argon with either hydrogen or helium. The plasma is initiated by an internal low current pilot arc between the electrode and the orifice. The pilot arc ionizes the orifice gas to ignite the primary arc between the electrode and the base metal. The arc plasma is constricted in size by the orifice around the electrode, and is called a transferred arc. If filler metal is used, it is fed into the arc as in the GTAW process.

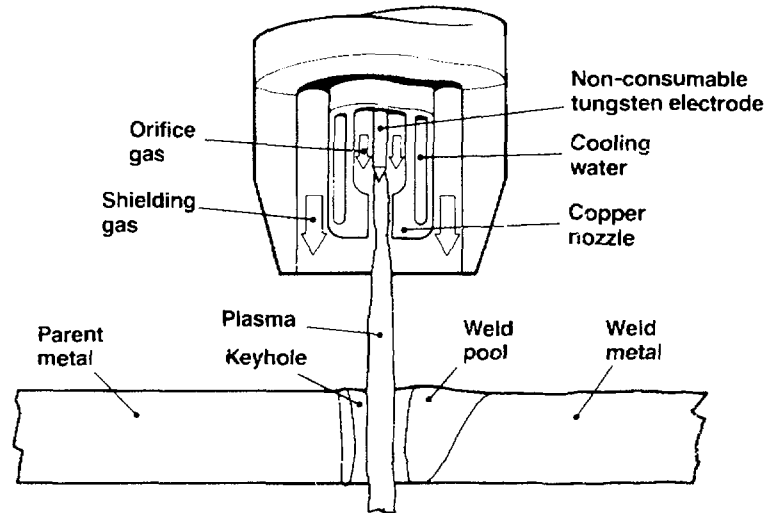

Figure 1.37: Plasma arc welding.

Resistance welding (RW)

Resistance welding incorporates a group of processes in which the heat for welding is generated by the resistance to the flow of electrical current through the parts being joined. It is most commonly used to weld two overlapping sheets or plates which may have different thicknesses. A pair of electrodes conduct electrical current to the joint. Resistance to the flow of current heats the facing surfaces, forming a weld. These electrodes clamp the sheets under pressure to provide good electrical contact and to contain the molten metal in the joint. The joint surfaces must be clean to obtain consistent electrical contact resistance to obtain uniform weld size and soundness.

The main process variables are welding current, welding time, electrode force, and electrode material and design. High welding currents are required to resistance heat and melt the base metal in a very short time. The time to make a single resistance heat and melt the base metal is very short usually less than one second.

There are four major resistance welding processes, namely, spot welding (RSW), projection welding (RPW), flash welding (RFW), and seam welding (RSEW). These processes are illustrated in Figure 1.38. In RSW, the welding current is concentrated at the point of joining using cylindrical electrodes. Spot welds are usually made one at a time. In RPW, a projection or dimple is formed in one part prior to welding. The projection concentrates the current at the facing surfaces. Large, flat electrodes are used on both sides of the components to produce several welds simultaneously. As an example, a stamped bracket may have three or four projections formed in it so that it can be welded to a sheet with one welding cycle. In seam welding, electrodes in the

form of rolls are used to transmit pressure and to send current through the overlapping sheet being moved between them. Flash welding is usually an automatic process. Parts are clamped in place by a welding operator who simply presses a button to start the welding sequence. The usual flash weld joins rods or bars end to end or edge to edge. The flashing action is continued until a molten layer forms on both surfaces. Then the components are forced together rapidly to squeeze out the molten metal. This produces a hot worked joint free of weld metal. The mechanical properties of flash welds are often superior to other types of welds.

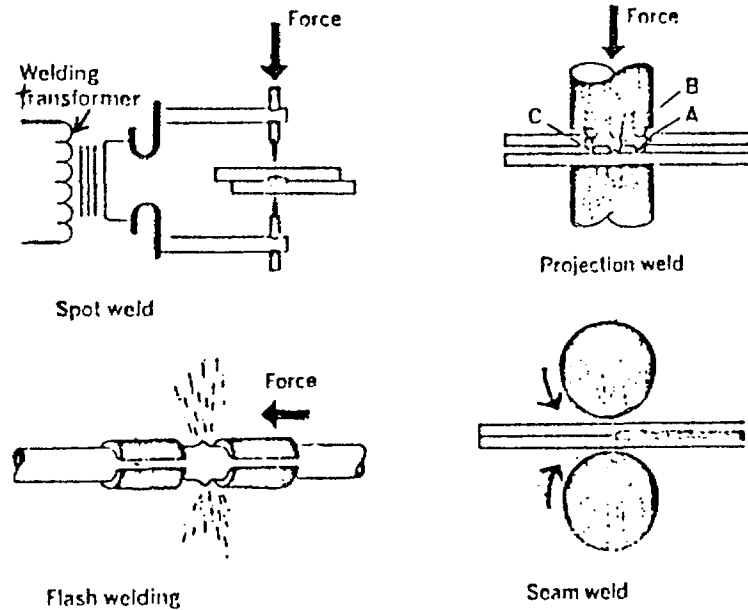

Figure 1.38: Basic resistance welding methods.

Oxyfuel gas welding (OFW)

Oxyfuel gas welding includes a group of welding processes that use the heat produced by a gas flame or flames for melting the base metal and, if used, the filler metal. Oxyfuel gas welding is an inclusive term used to describe any welding process that uses a fuel gas combined with oxygen to produce a flame having sufficient energy to melt the base metal. The fuel gas and oxygen are mixed in the proper proportions in a chamber which is generally a part of the welding torch assembly. The torch is designed to give the welder complete control of the welding flame to melt the base metal and the filler metal in the joint. This process is illustrated in Figure 1.39.

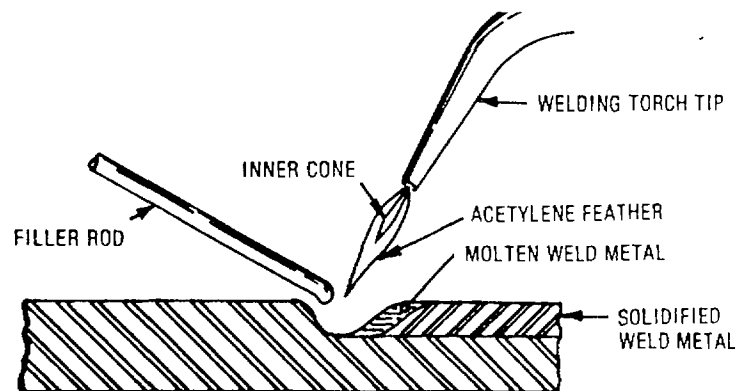

Figure 1.39: Oxyfuel gas welding process.

Oxyfuel gas welding is normally done with acetylene fuel gas. Other fuel gases, such as methyl acetylene propadiene and hydrogen, are sometimes used for oxyfuel gas welding of low melting metals. The welding flame must provide high localized energy to produce and sustain a molten weld pool. With proper adjustment, the flames can also supply a protective reducing atmosphere over the molten weld pool.

Oxyfuel gas welding can be used for joining thick plates, but welding is slow and high heat input is required. Welding speed is adequate to produce economical welds in sheet metal and thin-wall and small diameter piping. Thus, OFW is best applied on material of approximately 1/4 inches (6 mm) maximum thickness.

Brazing process

Brazing is a metal joining process where the base metal is heated to a temperature of about 425°C. Non-ferrous filler metals, such as brass or silver alloys, are melted by the heat of the base metal and flow by capillary attraction between the closely fitted surfaces of the joint. Heat for brazing is usually applied by flame torches, furnaces, electric induction, electric resistance or dropping the work into a hot salt bath. Filler and flux are either applied manually or are replaced in the form of powder, metallic rings or strips.

Miscellaneous welding processes

There are number of other welding processes sometimes encountered. Some of the important ones of these processes are briefly discussed below:

Electron beam and laser welding

These methods are generally utilized for precision assemblies requiring high-quality welds. The procedure is conducted by focusing an electron beam or laser beam on the joint interface and causing melting and fusion of the metal. Beam welds require that the mating of the components to be welded be fitted closely since there is no filler metal. The weld joint is created by the fusion of the material penetrated by the beam, therefore, the mating surface should be geometrically prepared so that they are in intimate contact over the entire joint surface.

Electron beam welds are usually made in a vacuum while laser welding is conducted using an inert gas surrounding the laser beam. At the present time, electron beam has the capability for welding thicker specimens (up to 200 mm in steel), but is limited by the size of the vacuum chamber.

Friction welding (FW)

In friction welding the heat for coalescence is produced by direct conversion of mechanical energy to thermal energy at the joint interface. The mechanical energy is generated by the sliding action between rotating or rubbing surfaces. The basic process involves holding a non-rotating workpiece in contact with a rotating workpiece under constant or gradually increasing pressure until the interface reaches welding temperature. The rotation is then stopped. It is a solid state process in which coalescence occurs at a temperature below the melting point of the metals being joined. Many ferrous and non-ferrous alloys can be friction welded, and the method can be used to join metals of widely differing thermal and mechanical properties.

Ultrasonic welding (USW)

Ultrasonic welding is a form of friction welding that has long been used to join plastics. Recently, such high frequency vibration has been successfully applied to the welding of metals, mostly non-ferrous metals.

It is known as a cold bonding process, because atomic combination and diffusion occurs while materials are in a semisolid or solid state. Although some heating occurs, welding depends more on the cleaning action of the process than on material heating.

In practice the parts to be welded are clamped under pressure between an anvil and a tip connected to a horn that vibrates at a high frequency. The welding tip and anvil may be contoured to the shape of the parts. The part in direct contact with the tip is rubbed at a high frequency against the stationary part. This vibratory action first erodes oxides and other contaminants on the interface surfaces. Once they are clean the surfaces come into intimate contact, and solid state bonding takes place.

Ultrasonic welding is best suited for joining small parts, sheet and foil. The process is fast, requires no consumables, and, because of its low heat, the result of the processing eliminates the need for further cleaning. In some instances, even coated, painted and badly rusted surfaces can be effectively joined without surface preparation.

Weld defects and discontinuities

During the process of welding, discontinuities of various types may occur. These may be classified under the headings of procedure and process, design, and metallurgical behaviour. The groups should be applied loosely because discontinuities listed in each group may have secondary origins in other groups. Discontinuities related to process, procedure, and design are, for the most part, those that alter stresses in a weld or heat-affected zone. Metallurgical discontinuities may also alter the local stress distribution, and in addition, may affect the mechanical or chemical (corrosion resistance) properties of the weld and heat-affected zone.

Porosity

Molten weld metal has a considerable capacity for dissolving gases which come into contact with it, such as hydrogen, oxygen and nitrogen. As the metal cools its ability to retain the gases diminishes. For instance, in steel the oxygen reacts with the carbon to form carbon monoxide, which is given off as a gas. With the change from the liquid to the solid state, there is reduced solubility with falling temperature. This causes an additional volume of gas to be evolved at a time when the metal is becoming mushy and therefore incapable of permitting the gas to escape freely. Entrapment of the gas causes gas pockets and porosity in the final weld. The type of porosity within a weld is usually designated by the amount and distribution of the pores. Some of the types are classified as follows: Figure 1.40.

Pipe or wormholes

Some gas inclusions have an elongated form known as pipes or wormholes. They are usually almost perpendicular to the weld surface. They can result from the use of wet powdered flux or from inadequate welding current. Another typical form of pipe has appearance of a branch of a tree Figure 1.41. These can be caused by use of wet welding electrodes.

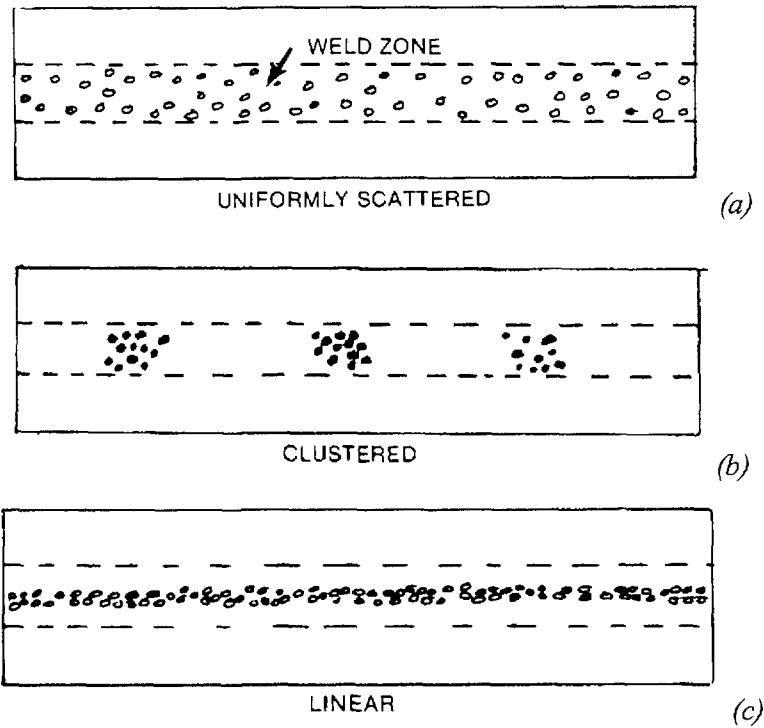

Figure 1.40: Three types of weld porosity.



Figure 1.41: Piping in weld.

The common causes of porosity, and suggested methods of preventing it, are summarized in Table 1.3.

Non-metallic inclusions

These may be the result of weld-metal contamination by substances on the surface of the joint or by the atmosphere. But the usual source is the slag formed by the electrode covering or flux used in the welding process. Some slag may be trapped in the deposited metal during its solidification, particularly if the metal fails to remain molten for a sufficient period to permit the slag to rise to its surface. In multi-pass welding, insufficient cleaning between weld passes can leave a portion of the slag coating in place to be covered by subsequent passes. A particular characteristic of slag inclusions is the slag line, intermittent or continuous. Such slag lines are often accompanied by a pronounced lack of fusion to the base metal. In general inclusions may be due to any one of several reasons which include failure to clean the surface of the joint, failure to remove slag from a previous deposit, incorrect edge preparation, incorrect manipulation of the electrode and insufficient arc shielding. The common causes and remedies of inclusion-type discontinuities are shown in Table 1.4.

TABLE 1.3: COMMON CAUSES AND REMEDIES OF POROSITY

Causes	Remedies
Excessive hydrogen, nitrogen, or oxygen in welding atmosphere	Use low-hydrogen welding process, filler metals high in deoxidizers; increase shielding gas flow
High solidification rate	Use preheat or increase heat input
Dirty base metal	Clean joint faces and adjacent surfaces
Dirty filler wire	Use specially cleaned and packaged filler wire, and store it in clean area
Improper arc length, welding current, or electrode manipulation	Change welding conditions and techniques
Volatilization of zinc from brass	Use copper-silicon filler metal; reduce heat input
Galvanized steel	Use E6010 electrodes and manipulate the arc heat to volatilize the zinc ahead of the molten weld pool
Excessive moisture in electrode covering or on joint surfaces	Use recommended procedures for baking and storing electrodes. Preheat the base metal
High sulphur base metal	Use electrodes with basic slagging reactions

TABLE 1.4: COMMON CAUSES AND REMEDIES OF SLAG INCLUSIONS

Causes	Remedies
Failure to remove slag	Clean the surface and previous weld bead
Entrapment of refractory oxides	Power wire brush the previous weld bead
Improper joint design	Increase groove angle of joint
Oxide inclusions	Provide proper gas shielding
Slag flooding ahead of the welding	Reposition work to prevent loss of slag control
Poor electrode manipulative technique	Change electrode or flux to improve slag control
Entrapped pieces of electrode covering	Use undamaged electrodes

Tungsten inclusions

Tungsten inclusions are particles of metallic tungsten embedded in the weld metal which originate from the tungsten electrode used in tungsten arc welding. Causes are excessive welding current allowing the melting and deposition of tungsten in the weld and incorrect polarity of electrode using a d.c. source. Tungsten inclusions can also be caused from dipping the electrode into the molten weld metal or by touching the filler rod to the electrode during welding. Tungsten inclusions frequently occur at the start of welds when the electrode may be cold. Small globular and widely scattered tungsten inclusions are sometimes permissible, but sharp edged inclusions are dangerous.

Lack of fusion

This is due to the lack of union in a weld between the weld metal and parent metal or between parent metal and parent metal or between weld metal and weld metal. Consequently the

lack of fusion can be of three types namely lack of side fusion, lack of root fusion and lack of inter-run fusion. The defect results mainly from the presence of slag, oxides, scale, or other non-metallic substances, too low a welding current or incorrect edge preparation. Incomplete fusion can also arise from too high a welding current when the high melt rate encourages the welder to use excessive welding speed. The defect reduces considerably the strength of a joint subjected to static loading, and under cyclic or shock loading it is quite serious. The causes and remedies for incomplete fusion are summarized in Table 1.5.

TABLE 1.5: COMMON CAUSES AND REMEDIES OF INCOMPLETE FUSION

Causes	Remedies
Insufficient heat input, wrong type or size of electrode, improper joint design, or inadequate gas shielding	Follow correct welding procedure specification
Incorrect electrode position	Maintain proper electrode position
Weld metal running ahead of the arc	Reposition work, lower current, or increase weld travel speed
Trapped oxides or slag on weld groove or weld face	Clean weld surface prior to welding

Incomplete root penetration

In butt welding, a root opening is usually left at the bottom of the groove (in one-side welding) or at the centre of the weld (in two-side welding). If the opening between the two plates is narrow, it is difficult to achieve complete penetration and fusion at the root of the weld. Therefore there can be a lack of fusion in the root of the weld or a gap left by the failure of the weld metal to fill the root of a butt weld Figure 1.42. It is caused by the electrode held at an incorrect angle, an electrode too large in diameter, a rate of travel too fast, an insufficient welding current, or an improper joint preparation (e.g. joint misalignment).



Figure 1.42: Incomplete root penetration.

Cracks

Cracks are linear ruptures of metal under stress. Although sometimes wide, they are often very narrow separations in the weld or adjacent base metal.

Cracks can occur in a wide variety of shapes and types and can be located in numerous positions in and around a welded joint Figure 1.43.

Cracks associated with welding may be categorized according to whether they originate in the weld itself or in the base metal. Four types commonly occur in the weld metal, i.e. transverse, longitudinal, crater and hat cracks. Base-metal cracks can be divided into seven categories, namely, transverse cracks, lamellar tearing, delaminations and fusion-line cracks.

(I) Transverse cracks

In the weld metal, these are formed when the predominant contraction stresses are in the direction of the weld axis (No. 2 in Figure 1.43). They can be hot cracks, which separate intergranularly as a result of hot shortness or localized planar shrinkage, or they can be transgranular separations produced by stresses exceeding the strength of the material. Transverse cracks lie in a plane normal to the axis of the weld and are usually open to the surface. They usually extend across the entire face of the weld and sometimes propagate into the base metal.

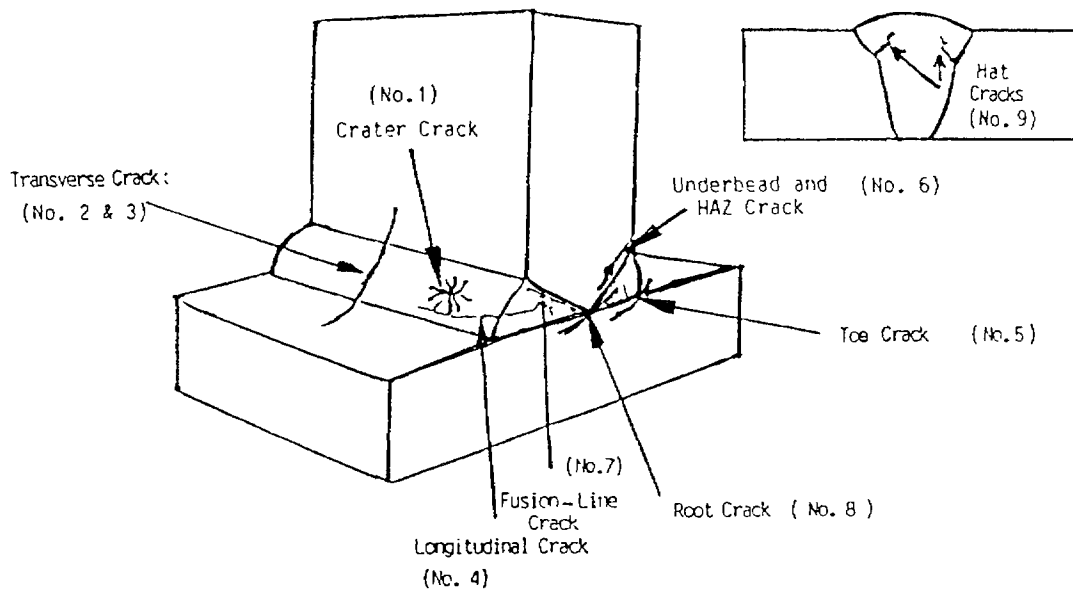

Figure 1.43: Different types of cracks located in and around a welded joint.

Transverse cracks in base metal (No. 3 in Figure 1.43) occur on the surface in or near the heat-affected zone. They are the result of the high residual stresses induced by thermal cycling during welding. High hardness, excessive restraint, and the presence of hydrogen promote their formation. Such cracks propagate into the weld metal or beyond the heat affected zone into the base metal.

(b) Underbead cracks

These are similar to transverse cracks in that they form in the heat-affected zone because of high hardness, excessive restraint, and the presence of hydrogen. Their orientation follows the contour of the heat-affected zone (No. 6 in Figure 1.43).

(c) Longitudinal cracks

These cracks may exist in three forms, depending on their position in the weld (No. 4 in Figure 1.43). Check cracks are open to the surface and extend only partway through the weld. Root cracks extend from the root to some point within the weld. Full centreline cracks may extend from the root to the face of the weld metal.

Check cracks are caused either by high contraction stresses in the final passes applied to a weld joint or by a hot-cracking mechanism.

Root cracks are the most common form of longitudinal weld-metal cracks because of the relatively small thickness and size of the root pass. If such cracks are not removed, they can propagate through the weld as subsequent passes are applied. This is the usual mechanism by which full centreline cracks are formed.

Centreline cracks may occur at either high or low temperatures. At low temperatures, cracking generally is the result of poor fit-up, overly rigid fit-up, or a small ratio of weld metal to base metal.

All three types of longitudinal cracks usually are oriented perpendicular to the weld face and run along the plane that bisects the welded joint. Seldom are they open at the edge of the joint face, because this requires a fillet weld with an extremely convex bead.

(d) Crater cracks

As the name implies, crater cracks occur in the weld crater formed at the end of a welding pass (No. 1 in Figure 1.43). Generally, this type of crack is caused by failure to fill the crater before breaking the arc. When this happens, the outer edges of the crater cool rapidly, producing stresses sufficient to crack the interior of the crater. This type of crack may be oriented longitudinally or transversely, or may occur as a number of intersecting cracks forming the shape of a star. Longitudinal crater cracks can propagate along axis of the weld to form a centreline crack. In addition, such cracks may propagate upward through the weld if they are not removed before subsequent passes are applied.

(e) Hat cracks

These cracks derive their name from the shape of the weld cross section with which they are usually associated. This type of weld flares out near the weld face, resembling an inverted top hat (No. 9 in Figure 1.43). Hat cracks are the result of using excessive voltage or too low a welding speed. The cracks are located about halfway up through the weld and extend into the weld metal from the fusion line of the joint.

(f) Toe and root cracks

These cracks occur in the root area of the weld or near the boundary between the weld metal and the parent metal (Nos 5 and 8 in Figure 1.43).

Undercut

During the final or cover pass the exposed upper edges of the bevelled weld preparation tend to melt and to run down into the deposited metal in the weld groove. The result is a groove which may be either intermittent or continuous, with more or less sharp edges along the weld reinforcement Figure 1.44.



Figure 1.44: Undercut.

TABLE 1.7: COMMON CAUSES AND REMEDIES OF CRACKING

Causes	Remedies
Highly rigid joint	Preheat; relieve residual stresses mechanically; minimize shrinkage stresses using backstep or block welding sequence
Excessive dilution	Change welding current and travel speed; weld with covered electrode negative, butter the joint faces prior to welding
Defective electrodes	Change to new electrode; bake electrodes to remove moisture
Poor fit-up	Reduce root opening; build up the edges with weld metal
Small weld bead	Increase electrode size; raise welding current; reduce travel speed
High sulphur base metal	Use filler metal low in sulphur
Angular distortion	Change to balanced welding on both sides of joint
Crater cracking	Fill crater before extinguishing the arc; use a welding current decay device when terminating the weld bead
Hydrogen in welding atmosphere	Use low-hydrogen welding process; preheat and hold for 2 h after welding or postweld heat treat immediately
Hot cracking	Use low heat input; deposit thin layers; change base metal
Low ductility	Use preheat; anneal the base metal
High residual stresses	Redesign the weldment; change welding sequence; apply intermediate stress-relief heat treatment
High hardenability	Preheat; increase heat input; heat treat without cooling to room temperature
Brittle phases in the microstructure	Solution heat treat prior to welding

Concavity at the root of the weld

A concave surface at the root of the weld can occur specially in pipe welding (without a cover pass on the root side). Root concavity is commonly produced by the flux cored arc welding (FCAW) process. In overhead welding this condition is a consequence of gravity which causes the molten metal to sag away from the inaccessible upper surface of the weld. It can also occur in downhand welding with a backing strip at the root of the weld groove if slag is trapped between the molten metal and the backing strip Figure 1.45.



Figure 1.45: Root concavity.

Excessive penetration

In welds molten metal sometimes runs through the root of the weld groove producing an excessive reinforcement at the back side of the weld. In general this is not continuous but has an irregular shape with characteristic hanging drops of excess metal Figure 1.46.

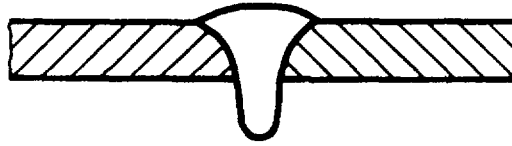

Figure 1.46: Excessive penetration.

Overlap

Overlap is an imperfection at the toe or root of a weld caused by an overflow of weld metal onto the surface of the parent metal, without fusing with the latter Figure 1.47. It is caused when the welding rod has been used at an incorrect angle, the electrode has travelled too slowly, or the current was too low.

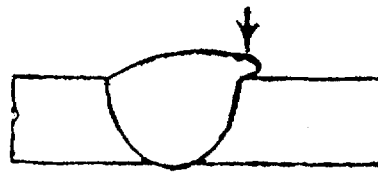

Figure 1.47: Overlap.

Lamellar tearing

This is a phenomenon that occurs in T-joints where the web plate is welded on both sides with usually full penetration welds. The stresses developed by this configuration result in a separation that takes place in the base metal between the roots of the two welds extending in a plane parallel to the surface of the base metal. Such a discontinuity is often associated with laminations or other planes of weakness in the metal. It is characterized by a step-like tear and caused by the shrinkage of the weld bead stressing the base metal through its thickness. This results initially in decohesion of non-metallic inclusions and then ductile tearing at about 45° between adjacent non-metallic inclusions to produce the step-like tears. Lamellar tearing can occur outside the heat affected zone 5–10 mm below the fusion face Figure 1.48.

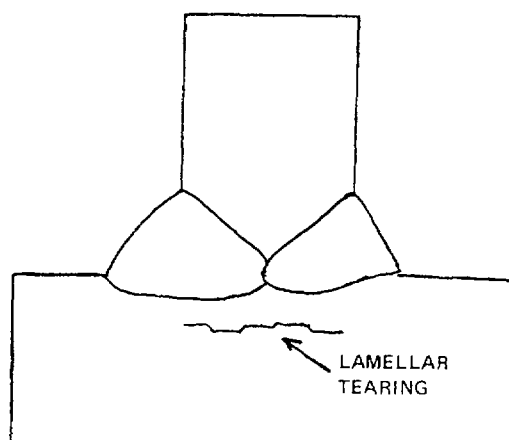

Figure 1.48: Lamellar tearing.

Burn through

A burn through area is that portion of the weld bead where excessive penetration has caused the weld pool to be blown into the pipe or vessel. It is caused by the factors, such as high current, slow rod speed, incorrect rod manipulation, etc., that produce excessive heat in one area. It is often accompanied by excessive drop through of the metal on the inside of the pipe. Figure 1.49.



Figure 1.49: Burn through.

Root pass oxidation

Oxidation is the result of insufficient protection of the weld and heat affected zone from the atmosphere. Severe oxidation will occur on stainless steels, for example, reducing corrosion resistance, if the joint is not purged with an inert gas.

Forging processes

Forging is the working of metal into a useful shape by hammering or pressing and is the oldest of the metal forming processes. Most forging operations are carried out hot, although some metals are cold-forged. The hot working of metals in the forging process results in an improvement in the mechanical properties. This method of shaping is therefore used in the manufacture of parts requiring good mechanical properties. Improvement in the mechanical properties results from a general consolidation of the metal and closing of gas and contraction cavities by means of mechanical pressure, a refinement of the crystal structure and a destruction of the continuity of intergranular concentrations of impurities and inclusions.

Forging is done on either a hammer or a press. A horizontal press (forging machine) is used in certain instances for forging small parts; otherwise forging machines are vertical, the lower die of which is fixed while the upper die is moveable, being carried on a vertical ram. In the case of hammers the die is raised mechanically and the blow is struck by the die falling freely Figure 1.50.

Forging may be considered under two categories. First where the working surface of the dies is flat or of uniform curved contour and shaping is done by manipulation using tools of simple shape. This is called open-die forging. The second is where impression dies are used and the metal is shaped by being forced into the die impressions. This is called closed-die forging. In the first category are forgings of simple, round or rectangular cross-section and forgings of more complicated shapes which are so large that sinking of closed dies would be impractical or too costly. Small forgings of complicated final shape may be rough forged on simple dies and then machined to final form if the number required is too small to justify the cost of an impression die. In this category also are hollow forged parts. For these, the centre metal of the rough piece of proper size is either machined out cold (trepanned), or is punched out hot using suitable dies on a press. The part is then forged on a mandrel passing through the centre hole and supported at both ends so that the mandrel acts as the bottom die. In closed die forging on a hammer or vertical press the lower die has an impression corresponding to one half of the part to be made while the upper die has an impression corresponding to the other half. For relatively simple shapes the dies may have only one impression but more commonly they incorporate a series of impressions in which the part is successively shaped to the final form. Closed die forging is commonly known as

'drop forging'. Around the impressions the dies are shaped to provide space for the excess stock, as it is not practical to have exactly the amount of metal required to fill the impressions. The excess metal that is forced into this space is referred to as flashing or flash. After forging this is trimmed off in suitable dies. The closed die forging business Figure 1.51 is so competitive that the losses in trim scrap provide one of the most important areas for economy.

The hot forging process whereby bolts, for example, are headed is referred to as hot upset forging or hot heading. In this process, a bar of uniform cross section is gripped between grooved dies and pressure is applied on the end in the direction of the axis of the bar by means of a heading tool. The metal flows under the applied pressure and fills the cavity between the dies.

Rolling processes

The flattening of metal between rollers is used for the production of strip, sheet, plate, bar and sections. Since the metal is formed by a squeezing action, rolling can be considered as a continuous forging process with the rolls acting as hammers and the metal being drawn down.

Rolling may be performed above the temperature of recrystallization (hot rolling) or below the temperature of recrystallization (cold rolling). Hot rolling is always used for the initial rolling of the cast ingot. Not only is it easier to break down the ingot to size quickly when it is hot and plastic, but the hot-rolling process closes any casting discontinuities and forge welds their surfaces together. This prevents any faults, which could lead to lamination, being carried forward into subsequent rolling operations. In hot rolling the coarse grains are first elongated and distorted and then formed into equi-axed crystals due to recrystallization. The crystals elongated and distorted by cold rolling do not recrystallize and the metal therefore remains work-hardened.

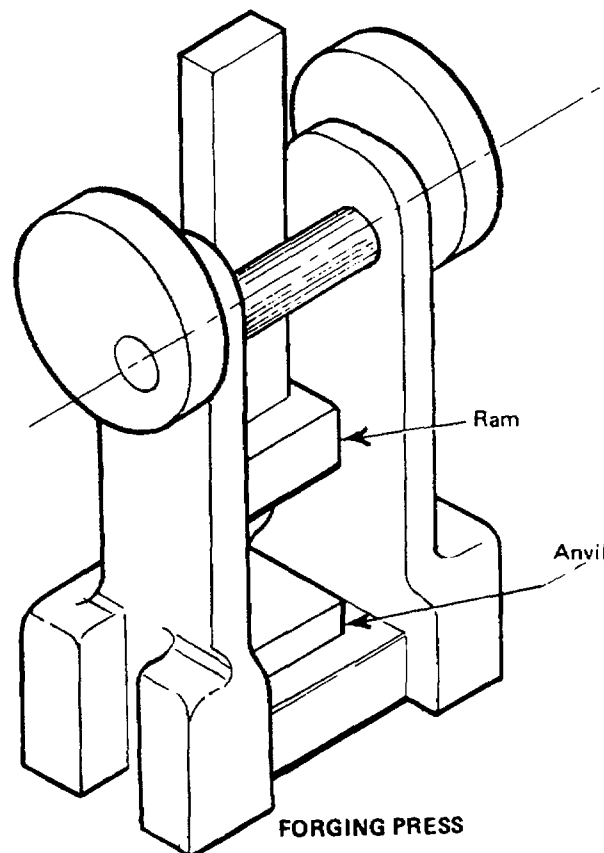

Figure 1.50: Vertical forging press.

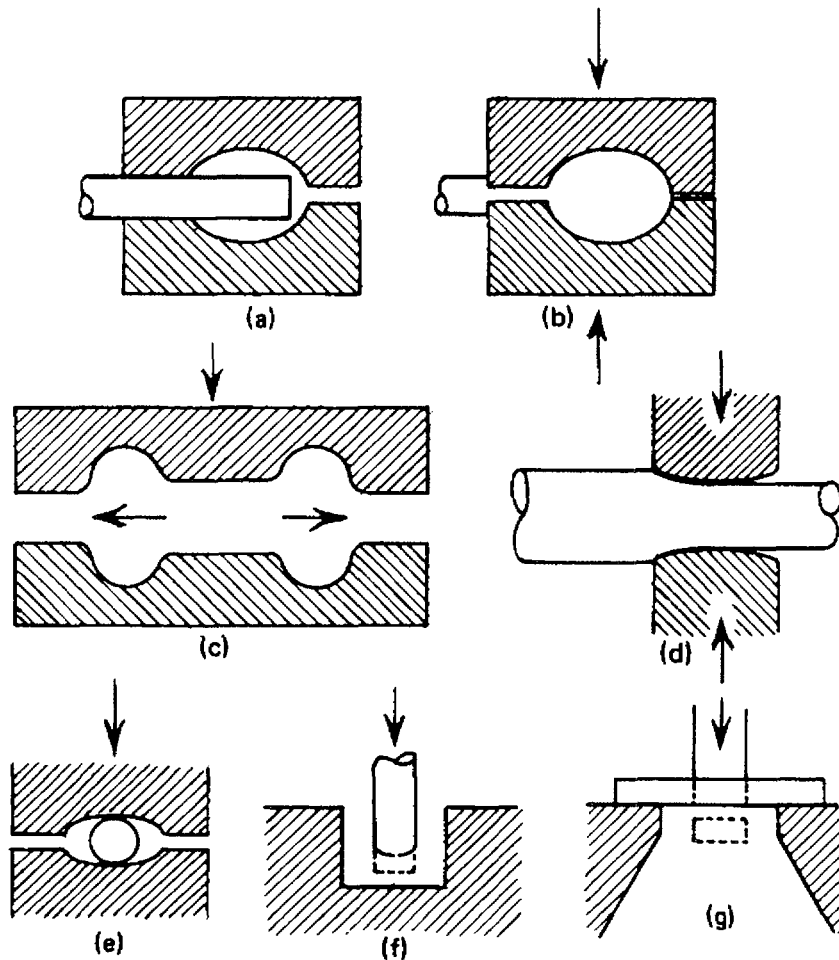

Figure 1.51: Forging operations; (a, b) edding; (c) fullering; (d) drawing, (e) swaging, (f) back extruding; (g) punching.

Rolling mills are described according to the arrangement of the rolls. The simplest is the two-high reversing mill Figure 1.52 (b). In this the metal is passed through from one side, the rolls are then lowered and their direction of rotation is reversed, and the metal is passed back through them. This cycle is repeated until the metal is of the required thickness. In the three-high mill Figure 1.52 (c) the rolls rotate continuously in one direction. The roller beds rise and fall to pass the metal between the lower two rolls first and then back again between the upper two rolls. The cycle is repeated until the metal is of the required thickness. In the four-high mill Figure 1.52 (d) and the cluster mill Figure 1.52 (e) the additional rolls 'back-up' the working rolls and allow them to apply greater pressure on the metal being rolled without deflection. Four-high and cluster mills operate in the same manner as the two-high reversing mill, and are widely used for cold rolling bright finished strip. Some typical rolling-mill processes are slabbing, cogging and re-rolling. Slabbing is the process of breaking down the ingot into slabs ready for re-rolling into strip, sheet and plate. The process is carried out at 1300°C and casting discontinuities in the ingot are welded by the process thus making the slab homogeneous. Cogging is similar to slabbing except that the ingot is rolled into 'blooms' ready for re-rolling into bars and sections. Two-high and four-high reversing mills are usually used for rolling both slabs and blooms. The re-rolling of slabs into strip is usually performed in a continuous strip mill. The slab is reheated to 1300°C and passed through a water spray and scale-breaking rolls to remove the scale left on the surface of the slab from previous processing. It is then roughed down, and finally passed to the finishing train of rolls. The strip is finally coiled ready for further processing. The re-rolling of sections and

bars is usually performed in two-high reversing mills fitted with grooved rolls. Some modern plants handling large quantities of standard section beams and joints are often laid out to provide a continuous train Figure 1.53.

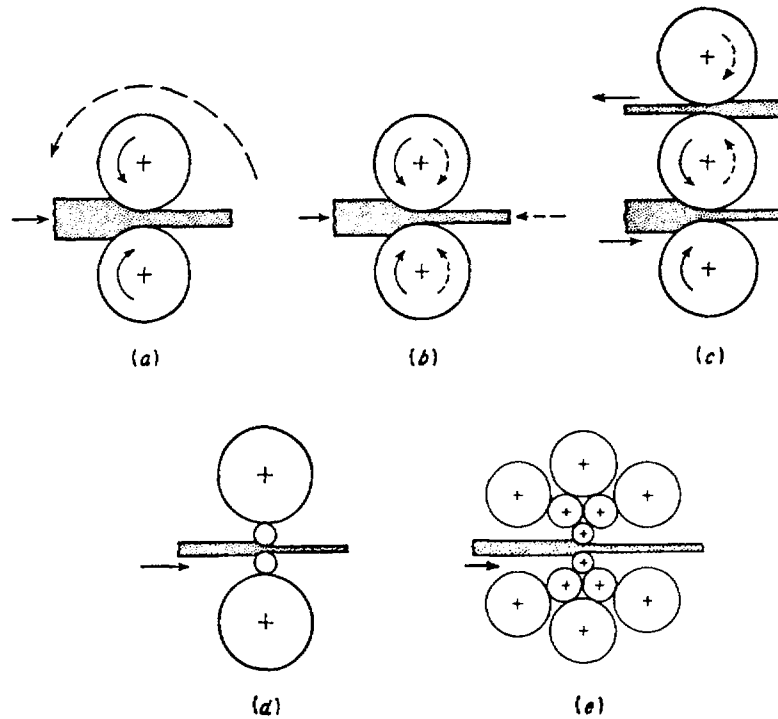

Figure 1.52: Typical arrangements of rolls for rolling mills; (a) Two-high pullover, (b) two-high reversing, (c) three-high, (d) four-high, (e) cluster.

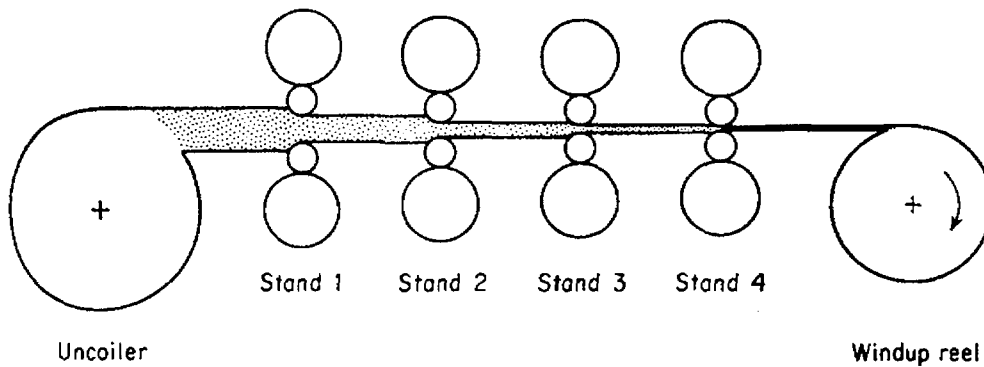

Figure 1.53: Schematic drawing of strip rolling on a four-stand continuous mill.

Whilst materials that are forged into wire and tube require the property of malleability, materials that are drawn into wire and tube require the property of ductility, combined with a relatively high tensile strength and a low work-hardening capacity as the process is performed cold. The reduction in size of the drawn section is provided by the material being pulled through a die. Rods and bars are drawn using draw-benches Figure 1.54.

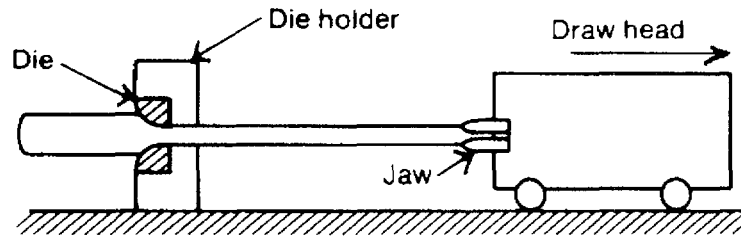

Figure 1.54: Schematic drawing of a drawbench.

Fine wire, especially the copper wire used for electrical conductors, is drawn on multiple-die machines. A capstan block pulls the wire through each die and passes it onto the next stage in the machine. As the wire becomes finer its length increases and the speed of the last capstan has to be very much higher than the first Figure 1.55.

Tube drawing is similar to rod drawing using a draw bench. However, the billet is pierced to start the hole and the tube is drawn over a mandrel. Where longer lengths of tube are required, the stock and the drawn tube have to be coiled. This prohibits the use of a fixed mandrel, and a floating mandrel or plug is used.

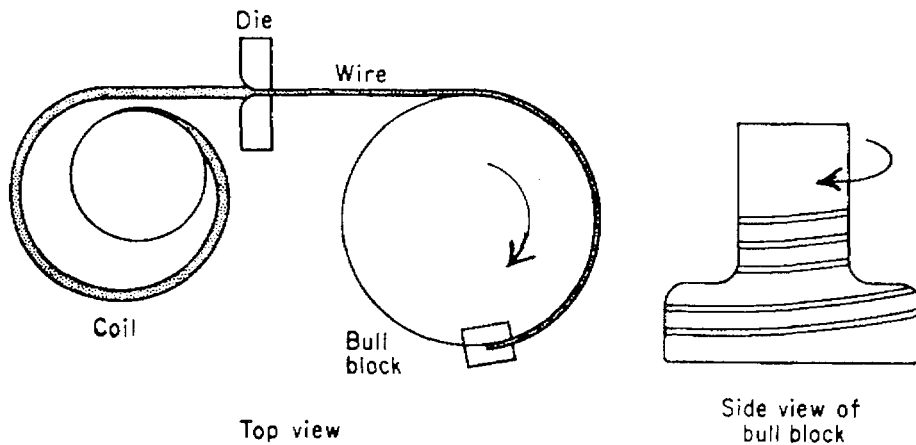
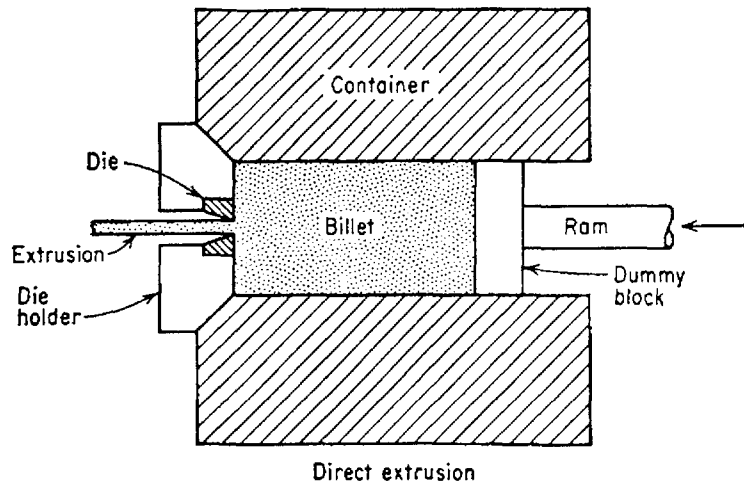

Figure 1.55: Schematic wiredrawing equipment.

Extrusion processes

Another process which is similar to rolling is extrusion. In principle, extrusion is similar to squeezing toothpaste from a toothpaste tube. The raw material is a heated cast billet of the required metal. Usually this is either a copper alloy, an aluminium alloy or lead. The pressure necessary to force the metal through the die is provided by the hydraulic ram. Since the billet is reduced to the size of the finished section in one pass through the die, extrusion is a highly productive process. However, the plant is extremely costly and so is its operation and maintenance. Like most hot processes the finish and dimensional accuracy of the section is lower than that associated with cold drawing.

Therefore, where greater accuracy is required, the extruded section is given a light draw to strengthen the section and finish, and improve its dimensional accuracy Figure 1.56 (a, b).



Direct extrusion

(a)

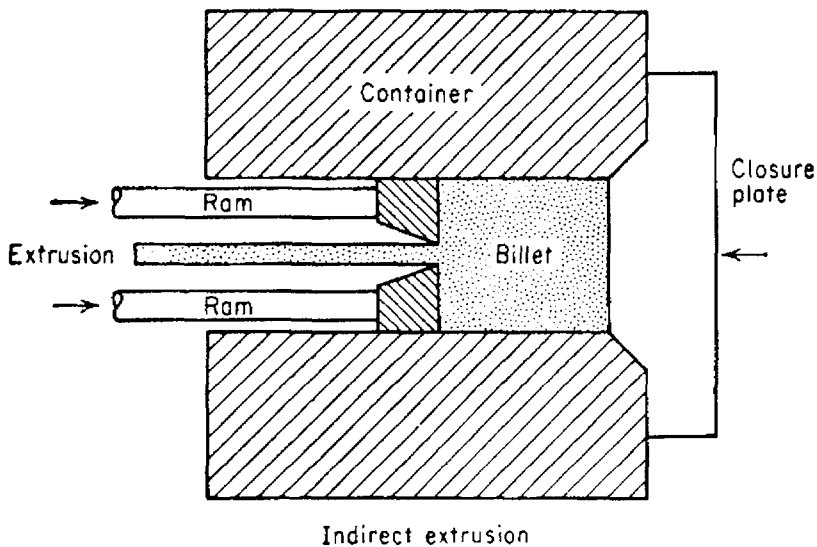

Indirect extrusion

(b)

Figure 1.56: Types of extrusion.

The Mannesmann mills, plug rolling mills, three-roll piercing mills, and reeling mills are also used for producing seamless pipe and tubing Figure 1.57. The Mannesmann mill Figure 1.57 (a) is used extensively for the rotary piercing of steel and copper billets. The process employs two barrel-shaped driven rolls which are set at an angle to each other. An axial thrust is developed as well as rotation to the billet. Because of the low arc of contact with the billet, tensile stresses develop along the axis of the billet. This assists in opening up the center of the billet as it flows around the piercing point to create the tube cavity. Piercing is the most severe hot-working operation customarily applied to metals. The Mannesmann mill does not provide sufficiently large wall reduction and elongation to produce finished hot-worked tubes. Various types of plug rolling mills which drive the tube over a long mandrel containing a plug Figure 1.57 (b) have been widely adopted. This has led to the development of three-roll piercing machines Figure 1.57

(c) which produce more concentric tubes with smoother inside and outside surfaces than the older Mannesmann design. A reeling mill Figure 1.57 (d) which burnishes the outside and inside surfaces and removes the slight oval shape is usually one of the last steps in the production of pipe or tubing.

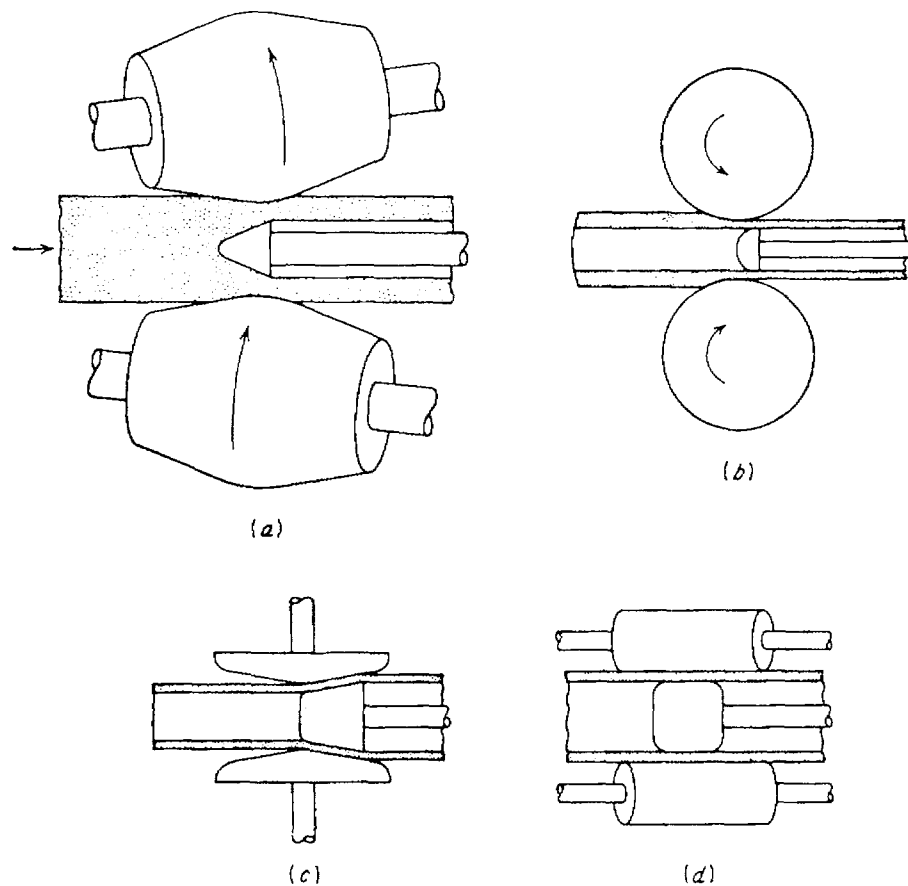

Figure 1.57: (a) Mannesmann mill, (b) plug rolling mill, (c) three-roll piercing mill, (d) reeling mill.

Spinning processes

A method of making tank heads, television cones, and other deep parts of circular symmetry is called spinning Figure 1.58 (a). The metal blank is clamped against a form block which is rotated at high speed. The blank is progressively formed against the block, either with a manual tool or by means of small diameter work rolls. In the spinning process the blank thickness does not change but its diameter is decreased. The shear spinning process Figure 1.58 (b) is a variant of conventional spinning. In this process the part diameter is the same as the blank diameter but the thickness of the spun part is reduced according to $t = t_0 \sin \alpha$. This process is also known as power spinning, flowturning, and hydrospinning. It is used for large axisymmetrical conical or curvilinear shapes such as rocket-motor casings and missile nose cones.

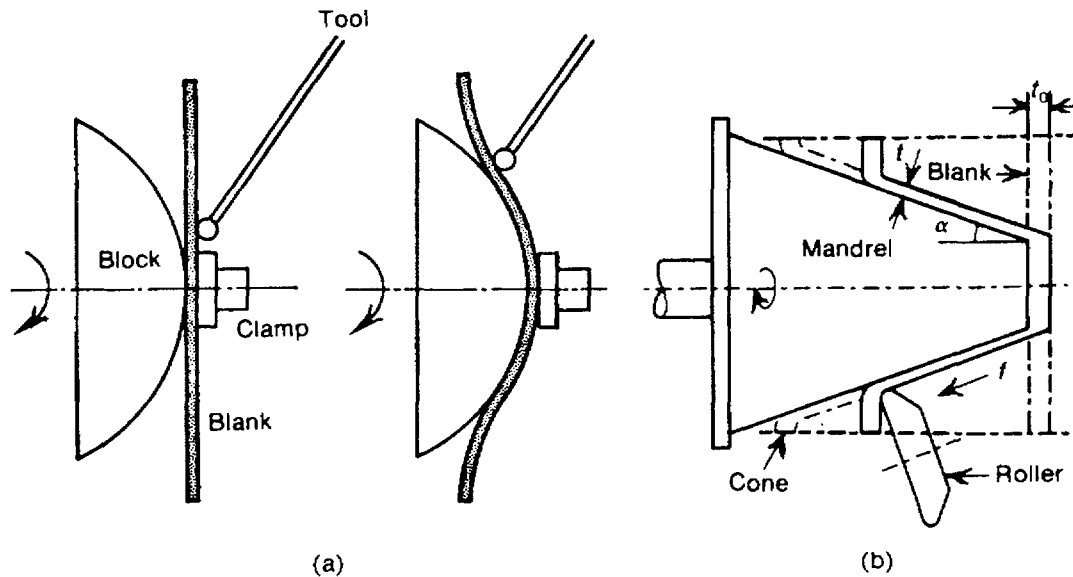

Figure 1.58: Schematic representation of spinning processes; (a) manual spinning, (b) shear spinning.

Shearing and blanking

Shearing is the separation of metal by two blades moving as shown in Figure 1.59. In shearing, a narrow strip of metal is severely plastically deformed to the point where it fractures at the surfaces in contact with the blades. The fracture then propagates inward to provide complete separation. The depth to which the punch must penetrate to produce complete shearing is directly related to the ductility of the metal. The penetration is only a small fraction of the sheet thickness for brittle materials, while for very ductile materials it may be slightly greater than the thickness.

The clearance between the blades is an important variable in shearing operations. With the proper clearance the cracks that initiate at the edges of the blades will propagate through the metal and meet near the centre of the thickness to provide a clean fracture surface Figure 1.59 (a), (b). Note that even with proper clearance there is still distortion at a sheared edge. Insufficient clearance will produce a ragged fracture and also will require more energy to shear the metal than when there is proper clearance. With excessive clearance there is greater distortion of the edge, and more energy is required because more metal must plastically deform before it fractures. Furthermore, with too large a clearance burrs or sharp projections are likely to form on the sheared edge. A dull cutting edge also increases the tendency for the formation of burrs. The height of the burr increases with increasing clearance and increasing ductility of the metal. Because the quality of the sheared edge influences the formability of the part the control of clearance is important. Clearances generally range between 2 and 10 per cent of the thickness of the sheet; the thicker the sheet the larger the clearance.

A whole group of press operations are based on the process of shearing. The shearing of closed contours, when the metal inside the contour is the desired part, is called blanking. If the material inside the contour is discarded, then the operation is known as punching, or piercing. Punching indentations into the edge of the sheet is called notching. Parting is the simultaneous cutting along at least two lines which balance each other from the standpoint of side thrust on the parting tool. Slitting is a shearing cut which does not remove any metal from the sheet. Trimming is a secondary operation in which previously formed parts are finished to size, usually by shearing excess metal around the periphery. The removal of flash in a press is a trimming operation. When the sheared edges of part are trimmed or squared up by removing a thin shaving of metal, the operation is called shaving.

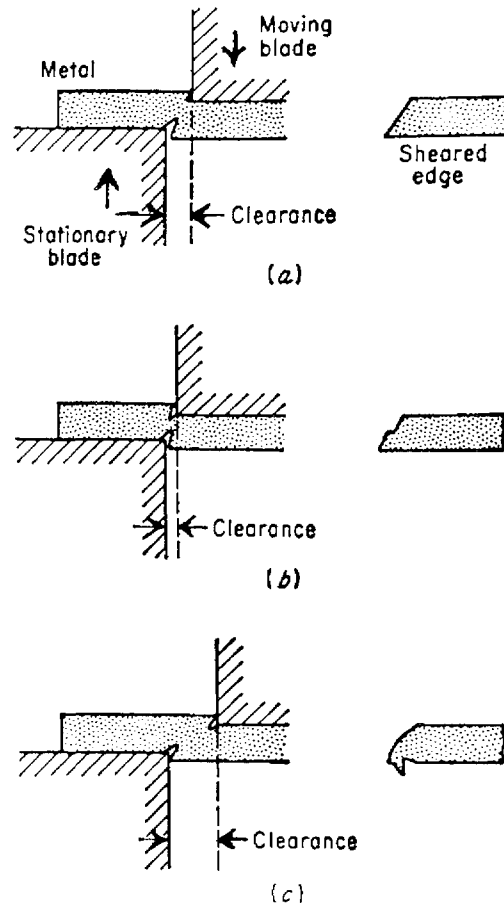

Figure 1.59: Shearing of metal; (a) proper clearance, (b) insufficient clearance, (c) excessive clearance.

Bending processes

Bending is the process by which a straight length is transformed into a curved length. It is a very common forming process for changing sheet and plate into channel, drums, tanks, etc. In addition, bending is part of the deformation in many other forming operations. The definition of the terms used in bending are illustrated in Figure 1.60. The bend radius R is defined as the radius of curvature on the concave, or inside, surface of the bend. For elastic bending below the elastic limit the strain passes through zero halfway through the thickness of the sheet at the neutral axis. In plastic bending beyond the elastic limit the neutral axis moves closer to the inside surface of the bend as the bending proceeds.

Deep drawing processes

Deep drawing is the metalworking process used for shaping of flat sheets into cup-shaped articles such as bathtubs, shell cases, and automobile panels. This is done by placing a blank of appropriate size over a shaped die and pressing the metal into the die with a punch Figure 1.61. Generally a clamping or hold-down pressure is required to press the blank against the die to prevent wrinkling. This is best done by means of a blank holder or hold-down ring in a double-action press.

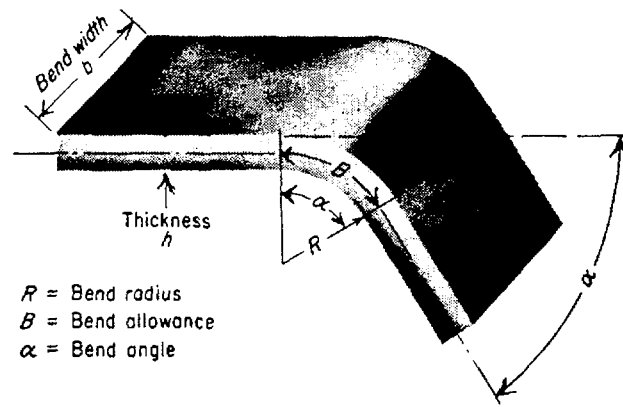

Figure 1.60: Definition of terms used in bending.

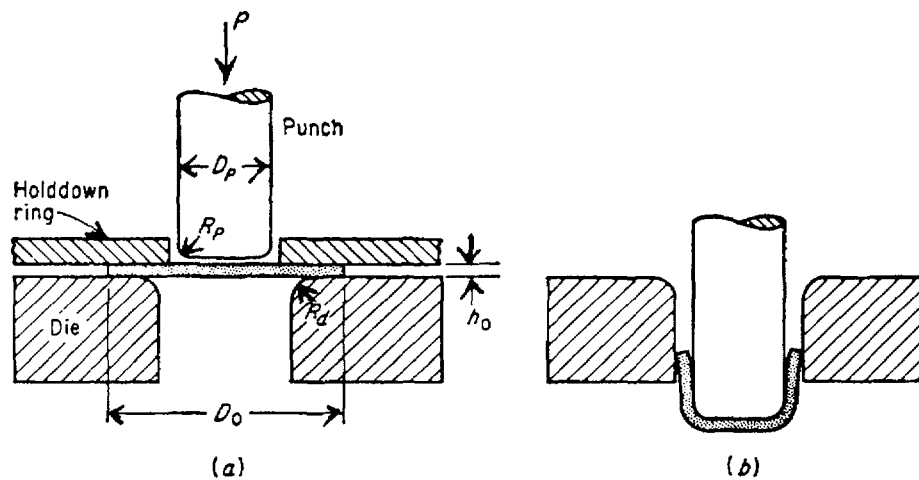

Figure 1.61: Deep-drawing of a cylindrical cup; (a) before bending, (b) after drawing.

Forging and rolling defects

Discontinuities in forgings may originate in the slab or billet and be modified by the rolling and forging of the material, or may result from the forging process itself. Some of the defects that can occur in forgings are similar to those in castings since most forgings originate from some form of cast ingot. Given below are some of the more specific defects.

Laminations

Large porosity, pipe and non-metallic inclusions in slabs or billets are flattened and spread out during the rolling and forging processes. These flattened discontinuities are known as laminations Figure 1.62.

Seams

Surface irregularities, such as cracks, on the slab or billet are stretched out and lengthened during rolling and are then called seams. Seams may also be caused by folding of the metal due to

improper rolling. Seams are surface discontinuities and on finished bars will appear as either continuous or broken straight lines. On round bar stock they will appear as straight or slightly spiral lines, either continuous or broken.

Forging laps

Forging laps are the discontinuities caused by the folding of metal in a thin plate on the surface of the forging. They are irregular in contour Figure 1.62.

Centre bursts

Ruptures that occur in the central region of a forging are called centre bursts. They can arise because of an incorrect forging procedure (e.g. too low a temperature or too drastic a reduction) or from the presence of segregation or brittle phase in the metal being forged Figure 1.62.

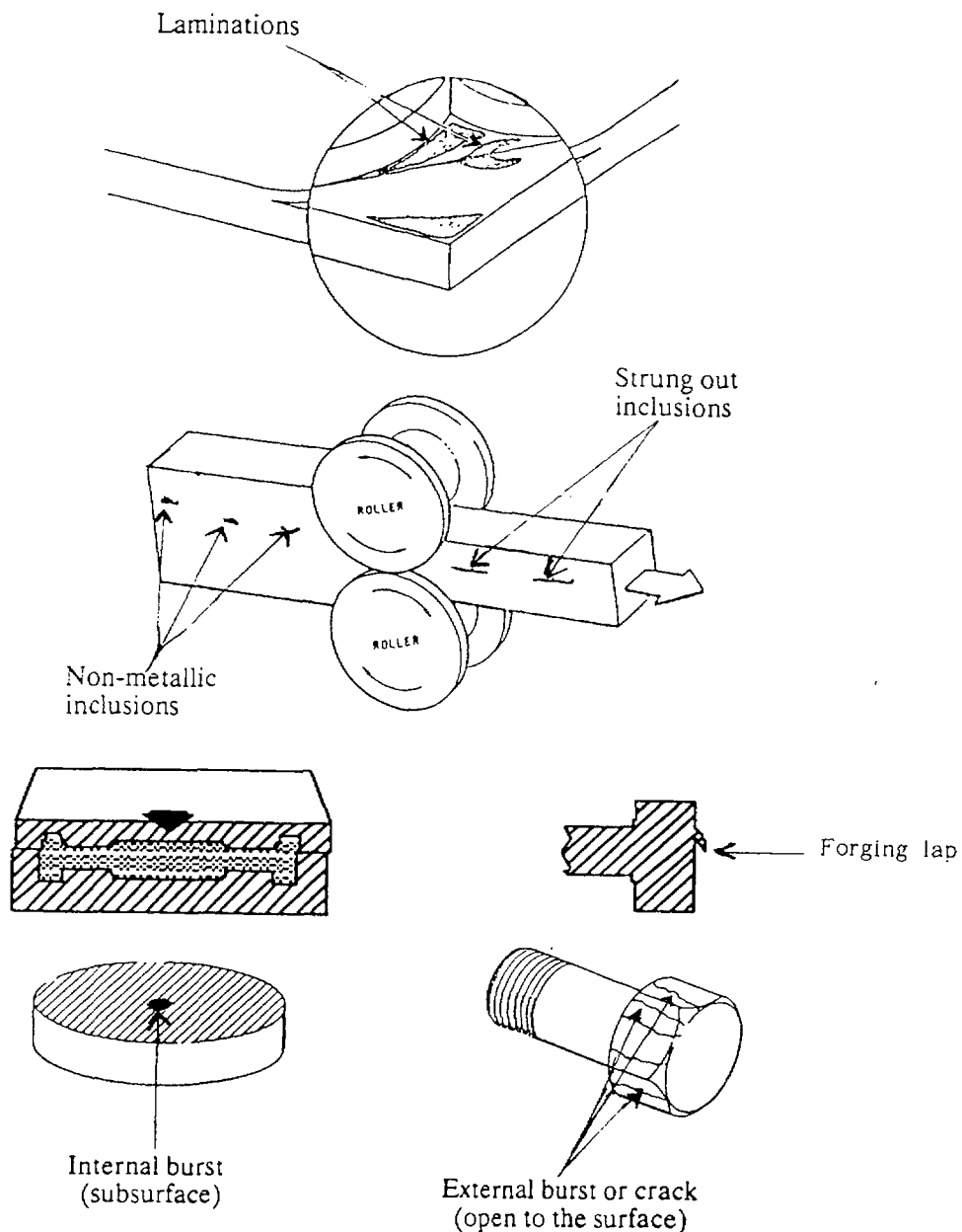

Figure 1.62: Forging and rolling defects.

Clinks (thermal cracks)

Clinks are cracks due to stresses arising from excessively high temperature gradients within the material. Cracks formed during too rapid cooling originate at the surface and extend into the body of the forging; those formed during too rapid heating occur internally and can be opened up to become diamond-shaped cavities, during subsequent forging.

Hairline cracks (flakes)

Flakes are very fine internal cracks of circular shape that develop and extend with time and are associated with the presence of hydrogen in steel. There is greater susceptibility in larger forgings than in smaller and in certain grades of alloy steel than in carbon steel; they can be avoided by correct treatment.

Hot tears

Surface defects due to metal being ruptured and pulled apart during forging. They may be associated with the presence of local segregation, seams, or brittle phases.

Stringers

Non-metallic inclusions in slabs or billets, that are thinned and lengthened in the direction of rolling by the rolling process are called stringers Figure 1.62.

Overheating

Normally identified by the facets seen on the fractured surfaces of a test-piece, but in extreme cases can manifest itself as a severely broken-up surface.

Pipe

If there has been insufficient discard from the original ingot, remnant primary pipe will normally show up axially. Secondary pipe that has never been exposed to the atmosphere will be welded-up if there has been sufficient forging.

Finishing processes and related defects

Machining process

Machining is a shape-producing process in which a power-driven device causes material to be removed in chip form. Most machining is done with equipment that supports both the workpiece and the cutting tool. Although there are many kinds of machines used in manufacturing industry, the term machine tools has been assigned to that group of equipment designed to hold a cutting tool and a workpiece and establish a suitable set of motions between them to remove materials from the work in chip form. The common combination of motions is shown in Figure 1.63.

Turning and boring

These machines normally rotate the workpiece to produce the cutting motion and feed a *single point tool parallel to the work axis or at some angle to it*. *External cylindrical machining is called turning, internal cylindrical machining is called boring, and making a flat surface by feeding the tool perpendicular to the axis of revolution is termed as facing.*

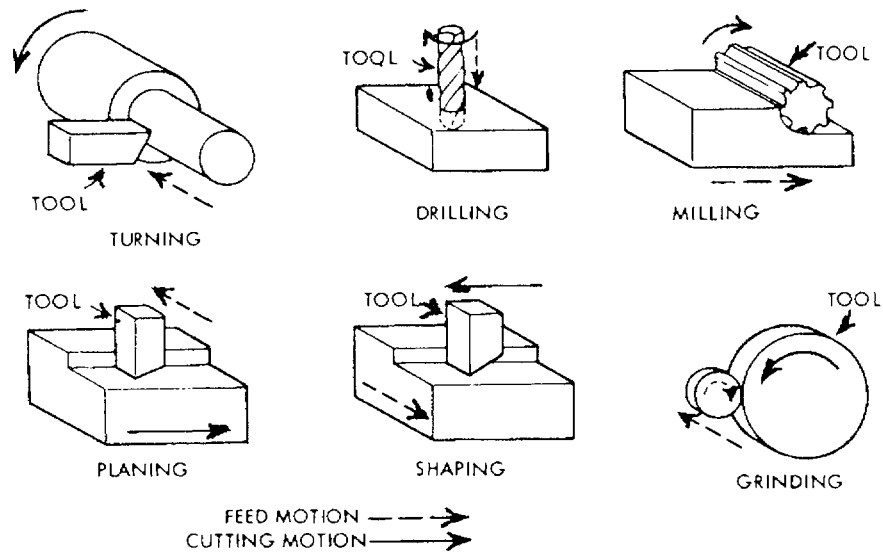

Figure 1.63: Feed and cutting motions.

Drilling

A special fluted tool with two or more cutting lips on its exposed end is called a drill and is rotated and advanced axially into the workpiece by use of a drill press. The principal work is the making of, or enlarging of, cylindrical holes.

Milling

There are a great variety of milling machines which like the drill press employ special multi-edge cutters. Except for some special production type milling machines, this equipment permits multi-direction feeding and the cutters perform their principal cutting on their periphery edges.

Straight line machines

One group of machine tools provide straight line cutting motion for its cutting action. This includes the shaper (straight line motion of the cutter), the planer (straight line motion of the workpiece), and the broach (straight line motion of a special multitooth cutter). Because of the high cost of the special cutter, broaching is used only for production quantity machining but the shaper and planer are more commonly used.

Machine tears are caused by dull machine tools. They will show up as short irregular lines at right angle to the direction of machining. They are the result of tool removing the metal more through a tearing action than through a cutting action.

Grinding processes

Grinding processes employ an abrasive wheel containing many grains of hard material bonded in a matrix. The action of a grinding wheel may be considered as a multiple-edge cutting tool except that the cutting edges are irregularly shaped and randomly spaced around the face of the wheel. Each grain removes a short chip of gradually increasing thickness, but because of the irregular shape of the grain there is considerable ploughing action between each grain and the workpiece.

The depth of cut in grinding usually is very small (a few μm), and this results in very small chips that adhere readily to the wheel or the workpiece. The net effect is that the specific cutting energy for grinding is about 10 times greater than for turning or milling. In grinding, greater than 70 per cent of the energy goes into the finished surface. This results in considerable temperature rise and generation of residual stresses.

Grinding cracks are a processing type discontinuity caused by stresses which are built up from excess heat created between grinding wheel and metal. Grinding cracks are fine sharp type cracks and will usually occur at right angles to the rotation of the grinding wheel.

Heat treatment of steel

A number of heat treatment cycles have been developed to alter the structure and hence the properties of iron and steel. Some of usual treatments and the specific properties they develop in iron and steel are discussed in the following Figure 1.64. The first is annealing. Steel is annealed to soften it for easy machining and to release internal stresses that might have been caused by working of the metal or by unequal contraction in casting. For annealing the steel is heated slowly to a temperature between 800°C and 1000°C . It is then held at this temperature for sufficient time so as to enable the internal changes to take place. It is then cooled slowly. For slow cooling, which is very essential, the heated steel is taken out of the furnace and embedded in sand, ash, lime or some other non-conducting material.

Normalizing is another heat treatment process. This treatment is done to refine the structure and to remove strains that might have been caused by cold working. When steel is cold worked its crystalline structure may get upset and the metal may become brittle and unreliable. Also when the metal is heated to very high temperatures as for forging then it may lose its toughness. To remedy these effects steel is slowly heated to about 1000°C and allowed to cool in air.

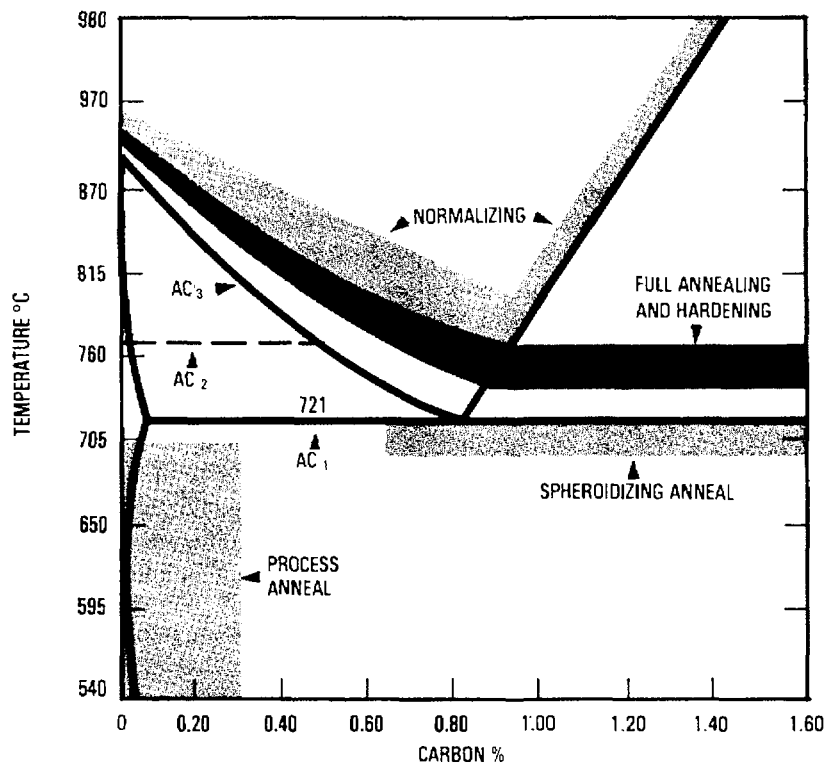

Figure 1.64: Temperature ranges for various heat treating processes.

Hardening or quenching of steel consists of heating the steel to above the transformation temperature and then suddenly cooling it by dipping it in a bath of cold water or oil. This way of cooling of hot steel is known as quenching or hardening. The steel after quenching is known as quenched steel. This type of steel is hard and brittle because of martensitic crystal structure. The hardness of quenched steel depends upon the medium used for quenching and the rate of cooling.

When steel is heated to or above its critical temperature (transformation temperature range the value of which is dependent upon the alloy percentages) and held at this temperature for some period of time carbon unites in solid solution with iron in the gamma or face centred cubic lattice form. In this phase, as much as 2% carbon can dissolve at the eutectic temperature of 1148°C at which the widest range of gamma composition exists. This is called the process of austenitization.

Tempering involves heating of hardened steel to a suitable temperature between 230°C and 600°C. This causes a particle transformation of the martensitic back to pearlite again thereby taking away some of the hardness of the steel to make it tougher.

Minimum hardness and maximum ductility of steel can be produced by a process called spheroidizing, which causes the iron carbide to form in small spheres or nodules in a ferrite matrix. In order to start with small grains that spheroids more readily, the process is usually performed on normalized steel. Several variations of processing are used, but all require the holding of the steel near the A1 temperature (usually slightly below) for a number of hours to allow the iron carbide to form in its more stable and lower energy state of small, rounded globules.

Heat treating cracks are often caused by stresses built up during heating and cooling. Unequal cooling between light and heavy sections may cause heat treatment cracks. Heat treatment cracks have no specific direction and usually start at sharp corners which act as stress concentration points (stress raisers).

Surface finishing

Products that have been completed to their proper shape and size frequently require some type of surface finishing to enable them to satisfactorily fulfil their function. In some cases, it is necessary to improve the physical properties of the surface material for resistance to penetration or abrasion. In many manufacturing processes, the product surface is left with dirt, metal chips, grease or other harmful material on it. Assemblies that are made of different materials or from the same materials processed in different manners, may require some special surface treatment to provide uniformity of appearance.

Surface finishing may sometimes become an intermediate step in processing. For instance, cleaning and polishing are usually essential before any kind of plating process. Some of the cleaning procedures are also used for improving surface smoothness on mating parts and for removing burrs and sharp corners, which might be harmful in later use. Another important need for surface finishing is for corrosion protection in variety of environments. The type of protection provided will depend largely upon the anticipated exposure, with due consideration to the material being protected and the economic factors involved.

Satisfying the above objectives necessitates the use of many surface finishing methods that involve chemical change of the surface, mechanical work affecting surface properties, cleaning by a variety of methods and the application of protective coatings, organic and metallic.

Case hardening of steels

Case hardening results in a hard, shell like surface. Some product applications require surface properties of hardness and strength to resist penetration under high pressure and to provide maximum wear properties. Where through hardness and the maximum strength associated with it are not necessary, it may be more economical to gain the needed surface properties by a case hardening process. Case hardening involves a change of surface properties to produce a hard, wear resistant shell with a tough fracture resistant core. This is usually accomplished by a change of surface material chemistry. With some materials, a similar condition can be produced by a phase change of the material already present.

Case depth measurement is sometimes checked by destructive methods, cutting the object, etching the cut surface and checking the cut depth with a measuring microscope. A faster and more useable method when knowledge is needed directly for service parts, is to use eddy current tests.

Carburizing

Case hardening of steel may be accomplished by a number of methods. The choice between them is dependent on the material to be treated, the application and the desired properties. One of the more common methods is carburizing which consists of an increase or addition of carbon to the surface of the part. Carburizing is usually performed on a low alloy or plain low carbon steel. If an alloy steel is used, it usually contains small quantities of nickel or some other elements that act as grain growth retarder during the heating cycle. Low carbon steels are commonly used to minimize the effect of subsequent heat treatment on the core material. It is possible to carburize any steel containing less than the 0.7% to 1.2% carbon that is produced in the surface material. The complete cycle for case hardening by carburizing is illustrated in Figure 1.65.

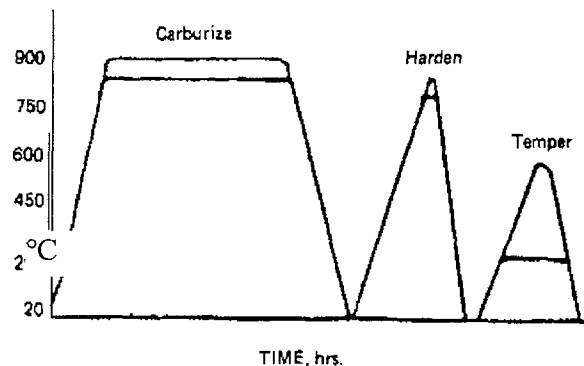

Figure 1.65: Typical heat treatment cycle for carburizing.

Flame hardening

Another case hardening process that does not require a change of composition in the surface material is flame hardening. This method can be used only on steels that contain sufficient carbon to be hardenable by standard heat treating procedures. The case is produced by selectively heating part or all of the surface with special high capacity gas burners or oxy-acetylene torches at a rate sufficiently high that only a small depth from the surface goes above the critical temperature. Following immediately behind the torch is a water quenching head that floods the surface to reduce the temperature fast enough to produce a martensitic structure. As in the case of carburizing, the surface may be then reheated to temper it for toughness improvement. The depth

of hardness is controlled by the temperature to which the metal is raised, by the rate of heating, and by the time that passes before quenching.

Cleaning

Few, if any, shaping and sizing processes produce products that are suitable without some type of cleaning unless special precautions are taken. Hot working, heat treating, and welding cause oxidation and scale formation in the presence of oxygen. For the same reason, castings are usually coated with oxide scale. If they are made in sand moulds they may have sand grains fused or adhering to the surface. Residue from coolants, lubricants and other processing materials is common on many manufactured parts. In addition to greasy films from processing, protective coatings of greases, oils, or waxes are frequently used intentionally to prevent rust or corrosion on parts that are stored for some period of time before being put to use. Even if parts are clean at the completion of manufacturing, they seldom remain that way for long. After only short storage periods, corrosion and dust from atmospheric exposure necessitate cleaning particularly if further processing is required.

When using NDT methods such as penetrant testing and ultrasonic testing good precleaning may be necessary to get accurate results and postcleaning is often needed to leave the surface in a suitable condition. In some applications such as on stainless steels and nickel based alloys, ultrasonic couplants and penetrant materials must be made of only certain materials so that they do not cause stress-corrosion failure.

Cleaning sometimes has finish improvement associated with it. Some shape producing methods produce unsatisfactory surface characteristics such as sharp corners, burrs and tool marks which may affect the function, handling ease, and appearance of the product. Some cleaning processes at least partially blend together surface irregularities to produce uniform light reflection. Improvement of surface qualities may be accomplished by removal of high spots by cutting or by plastic flow as cleaning is performed.

Many different cleaning methods are available. The most commonly used ones are briefly mentioned here: the most widely used cleaning methods use a cleaning medium in liquid form, which are applied to the object to be cleaned in different ways such as spraying, brushing or dipping the object in a bath of the cleaning liquid. Cleaning may be carried out through the process of blasting wherein the cleaning medium which may be a liquid or a solid (e.g. sand, glass or steel beads, etc.) is accelerated to high velocity and impinged against the surface to be cleaned. A number of cleaning operations can be quickly and easily performed by use of wire brushes either manually or by rotating them at high speeds. The cleaned surface may be given a final polishing touch using a flexible abrasive wheel. Buffing is a kind of polishing process.

Coatings

Many products, in particular those exposed to view and those subject to change by the environment with which they are in contact, need some type of coating for improved appearance or for protecting from chemical attack. All newly created surfaces are subject to corrosion, although the rate of occurrence varies greatly with the material, the environment, and the conditions. For all practical purposes, some materials are highly corrosion resistant because the products of corrosion resist further corrosion. For example, a newly machined surface on an aluminium alloy will immediately be attacked by oxygen in the air. The initial aluminium oxide coating protects the remaining metal and practically stops corrosion unless an environmental change occurs. Corrosion rates are closely dependent on environment. Rates increase with rise of temperature and greater concentration of the attacking chemical. The need for corrosion protection for maintenance of appearance is obvious. Unless protected, an object made of bright

steel will begin to show rust in a few hours of exposure to ordinary atmosphere. In addition to change of appearance, loss of actual material, change of dimensions, and decrease of strength, corrosion may be the cause of eventual loss of service or failure of a product.

Hardness and wear resistance can, however, be provided on a surface by plating with hard metals. Chromium plating of gauges subject to abrasion is frequently used to increase their wear life. Coatings of plastic materials and asphaltic mixture are sometimes placed on surfaces to provide sound deadening. The additional benefit of protection from corrosion is usually acquired at the same time.

Metallizing

Metal spraying, or metallizing, is a process in which metal wire or powder is fed into an oxy-acetylene heating flame and the same after melting, is carried by high velocity air to be impinged against the work surface. The small droplets adhere to the surface and bond together to build up a coating. The nature of the bond is dependent largely on the materials. The droplets are relatively cool when they make contact and in fact can be sprayed on wood, leather, and other flammable materials. Little, if any, liquid flow aids the bonding action. If, however, sufficient affinity exists between the metals, a type of weld involving atomic bonds may be established. The bond is largely mechanical in most cases and metal spraying is usually done on surfaces that have been intentionally roughened to aid the mechanical attachment. Zinc, aluminium, and cadmium, which are anodic to steel and therefore provide preferential corrosion protection, are usually sprayed in thin layers, averaging about 0.25 millimetre (0.010 inch) in thickness, as protective coatings. Because sprayed coatings tend to be porous, coatings of two or more times this thickness are used for cathodic materials such as tin, lead, and nickel. The cathodic materials protect only by isolating the base material from its environment.

Several metals, mainly zinc, tin, and lead, are applied to steel for corrosion protection by a hot dip process. Steel in sheet, rod, pipe, or fabricated form, properly cleansed and fluxed, is immersed in molten plating metal. As the work is withdrawn the molten metal that adheres solidifies to form a protective coat.

Coating of many metals can be deposited on other metals, and on non-metals by electroplating, when suitably prepared. This is based on the principle that when direct current power of high enough voltage is applied to two electrodes immersed in a water solution of metallic salt, current will flow through the circuit causing changes at the electrodes Figure 1.66. At the negative electrode, or cathode (the work), excess electrons supplied from the power source neutralize positively charged metallic ions in the salt solution to cause dissolved metal to be deposited in the solid state. At the positive electrode, or anode (plating metal), metal goes into solution to replace that removed at the other electrode. The rate of deposition and the properties of the plated material are dependent on the metals being worked with, the current density, the solution temperature, and other factors.

Chemical treatment

A relatively simple and often fully satisfactory method for protection from corrosion is by conversion of some of the surface material to a chemical composition that resists attack from the environment. These converted metal surfaces consist of relatively thin (seldom more than 0.025 millimetre, or 0.001 inch thick) inorganic films that are formed by chemical reaction with the base material. One important feature of the conversion process is that the coatings have little effect on the product dimensions. However, when severe conditions are to be encountered, the converted surface may give only partial protection, and coatings of entirely different types may be applied over them.

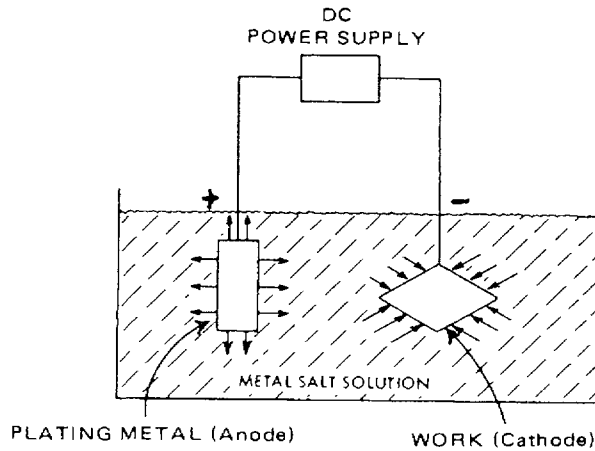

Figure 1.66: Electroplating.

Aluminium, magnesium, and zinc can be treated electrically in a suitable electrolyte to produce a corrosion-resistant oxide coating. The metal being treated is connected to the anode in the circuit, which provides the name anodizing for the process.

Phosphate coatings, used mostly on steel, result from a chemical reaction of phosphoric acid with the metal to form a non-metallic coating that is essentially phosphate salts. The coating is produced by immersing small items or spraying large items with the phosphating solution.

A number of proprietary blackening processes, used mainly on steel, produce attractive black oxide coatings. Most of the processes involve the immersing of steel in a caustic soda solution heated to about 150°C (300°F) and made strongly oxidizing by the addition of nitrites or nitrates. Corrosion resistance is rather poor unless improved by application of oil, lacquer, or wax. As in the case of most of the other chemical conversion procedures this procedure also finds use as a base for paint finishes.

1.4. Materials in service

1.4.1. Behaviour of materials in service

Materials have to operate and perform in widely varied environments and situations. The requirements of safety and reliability demand that the materials and components should perform well in their environments and situations without premature failure. There are a number of factors and processes which can cause the failure of materials. As premature failure of critical components can be disastrous in many situations apart from being a cause for lost production and bad reputation, it is essential to understand and control these causes of failure.

1.4.2. Conditions leading to defects and failures

Due to advances in technology and the understanding of materials and their design, and due to sophisticated inspection and testing methods, such as the non-destructive testing methods, metal failures occur only in an extremely low percentage of the millions of tons of metals fabricated every year. Those that do occur fall mainly into three categories. Operational failures can be caused by overload, wear, corrosion and stress-corrosion, brittle fracture and metal fatigue. In the second category fall the failures due to improper design. In this it is necessary to consider whether sharp corners or high-stress areas exist in the design, has sufficient safety stress factor been considered and whether the material selected is suitable for particular application. The third type of failure is caused by thermal treatments such as forging, hardening, tempering and welding,

and by surface cracks caused by the heat of grinding. These aspects and especially those related to operational or in-service conditions will be described here in more detail.

Corrosion

With the exception of some noble metals, all metals are subject to the deterioration caused by ordinary corrosion. Iron, for example, tends to revert back to its natural state of iron oxide. Other metals revert to sulphides and oxides or carbonates. Buildings, ships, machines and automobiles are all subject to attack by the environment. The corrosion that results often renders them useless and they have to be scrapped. Billions of dollars a year are lost as a result of corrosion. Corrosion can also cause dangerous conditions to prevail, such as on bridges, where the supporting structures have been eaten away, or in aircraft in which an insidious corrosion called intergranular corrosion can weaken the structural members of the aircraft and cause a sudden failure.

Corrosion in metals is the result of their desire to unite with oxygen in the atmosphere or in other environments to return to a more stable compound, usually called ore. Iron ore, for example, is in some cases simply iron rust. Corrosion may be classified by the two different processes by which it can take place; direct oxidation corrosion, which usually happens at high temperature, and galvanic corrosion, which takes place at normal temperatures in the presence of moisture or an electrolyte. Direct oxidation corrosion is often seen in the scaling that takes place when a piece of metal is left in a furnace for a length of time. The black scale is actually a form of iron oxide, called magnetite (Fe_3O_4). Galvanic corrosion is essentially an electrochemical process that causes a deterioration of metals by a very slow but persistent action. In this process, part or all of the metal becomes transformed from the metallic state to the ionic state and often forms a chemical compound in the electrolyte. On the surface of some metals such as copper or aluminium, the corrosion product sometimes exists as a thin film that resists further corrosion. In other metals such as iron, the film of oxide that forms is so porous that it does not resist further corrosive action, and corrosion continues until the whole piece has been converted to the oxide.

Corrosion requires the presence of an electrolyte to allow metal ions to go into solution. The electrolyte may be fresh or salt water and acid or alkaline solutions of any concentration. Even a finger print on metal can form an electrolyte and produce corrosion. When corrosion of a metal occurs, positively charged atoms are released or detached from the solid surface and enter into solution as metallic ions while the corresponding negative charges in the form of electrons are left behind in the metal. The detached positive ions bear one or more positive charges. In the corrosion of iron, each iron atom releases two electrons and then becomes a ferrous iron carrying two positive charges. Two electrons must then pass through a conductor to the cathode area. The electrons reach the surface of the cathode material and neutralize positively charged hydrogen ions that have become attached to the cathode surface. Two of these ions will now become neutral atoms, and are released generally in the form of hydrogen gas. This release of the positively charged hydrogen ions leaves an accumulation and a concentration of OH negative ions that increases the alkalinity at the cathode. When this process is taking place, it can be observed that hydrogen bubbles are forming at the cathode only. When cathodes and anodes are formed on a single piece of metal, their particular locations are determined by, for example, the lack of homogeneity in the metal, surface imperfections, stresses, inclusions in the metal, or any thing that can form a crevice such as a washer.

Corrosion can also take the form of erosion in which the protective film, usually an oxide film, is removed by a rapidly moving atmosphere or medium. Depolarization can also take place, for example, on the propellers of ships because of the movement through the water, which is the electrolyte. This causes an increased corrosion rate of the anodic steel ship's hull. Impellers of pumps are often corroded by this form of erosion corrosion in which metal ions are rapidly removed at the periphery of the impeller but are concentrated near the centre where the velocity is

lower. Another form of corrosion is intergranular corrosion. This takes place internally. Often the grain boundaries form anodes and the grains themselves form cathodes, causing a complete deterioration of the metal in which it simply crumbles when it fails. This often occurs in stainless steels in which chromium carbides precipitate at the grain boundaries. This lowers the chromium content adjacent to the grain boundaries, thus creating a galvanic cell. Differences in environment can cause a high concentration of oxygen ions. This is called cell concentration corrosion. Pitting corrosion is localized and results in small holes on the surface of a metal caused by a concentration cell at that point. When high stresses are applied to metals in a corrosive environment, cracking can also be accelerated in the form of stress-corrosion failure. It is a very localized phenomenon and results in a cracking type of failure. Cathodic protection is often used to protect steel ships hulls and buried steel pipelines. This is done by using zinc and magnesium sacrificial anodes that are bolted to the ship's hull or buried in the ground at intervals and electrically connected to the metal to be protected. In the case of the ship, the bronze propeller acts as a cathode, the steel hull as an anode and the seawater as an electrolyte. Severe corrosion can occur on the hull as a result of galvanic action. The sacrificial anodes are very near the anodic end of the galvanic series and have a large potential differences between both the steel hull of the ship and the bronze propeller. Both the hull and propeller become cathodic and consequently do not deteriorate. The zinc or magnesium anodes are replaced from time to time. Selection of materials is of foremost importance. Even though a material may be normally resistant to corrosion, it may fail in a particular environment or if coupled with a more cathodic metal. Coatings are extensively used to prevent corrosion. There are different types of such coatings, for example; anodic coatings, cathodic coatings, organic and inorganic coatings, inhibitive coatings, etc.

Fatigue

When metal parts are subjected to repeated loading and unloading over prolonged periods they may fail at stresses far below their yield strength with no sign of plastic deformation. This is called a fatigue failure. When designing machine parts that are subject to vibration or cyclic loads, fatigue strength may be more important than ultimate tensile or yield strength. Fatigue is a universal phenomenon observed in most solids. Cyclic loading leads to a continuous accumulation of damage which, as in the case of static fracture, eventually results in rupture. Fatigue limit, or endurance limit, is the maximum load that can be applied an infinite number of times without causing failure Figure 1.67. But 10 million loading cycles are usually considered enough to establish fatigue limits. The number of cycles leading to fracture at a given stress is often referred to as the fatigue strength or endurance. This phenomenon of failure of a material when subjected to a number of varying stress cycles is known as fatigue since it was once thought that fracture occurred due to the metal weakening or becoming tired.

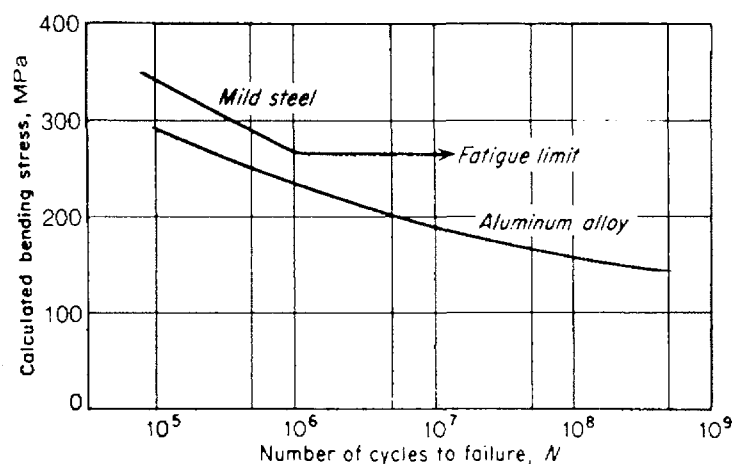

Figure 1.67: Typical fatigue curves for ferrous and non-ferrous metals.

Failures caused by fatigue are found in many of the materials of industry. Some plastics and most metals are subject to fatigue in varying degrees as these are widely used in dynamically loaded structures and machines. It has been estimated that at least 75% of all machine and structure failures have been caused by some form of fatigue. Fatigue failure is caused by a crack that is initiated by a notch, bend, or scratch that continues to grow gradually as a result of stress reversals on the part. The crack growth continues until the cross-sectional area of the part is reduced sufficiently to weaken the part to the point of failure. In welding, even spatter on a sensitive surface such as a steel spring can initiate fatigue failure. Fatigue is greatly influenced by the kind of material, grain structure and the kind of loading. Some metals are more sensitive to sharp changes in section (notch sensitive) than others.

There are various types of fatigue failure. In the case of one-way bending load a small elliptically shaped fatigue crack usually starts at a surface flaw such as a scratch or tool mark. The crack tends to flatten out as it grows. It is caused by the stress at the base of the crack being lower because of the decrease in distance from the edge of the crack to the neutral axis. If a distinct stress raiser such as a notch is present, the stress at the base of the crack would be high, causing the crack to progress rapidly near the surface, and the crack tends to flatten out sooner. In a two-way bending load cracks start almost simultaneously at opposite surfaces when the surfaces are equally stressed. The cracks proceed toward the centre at similar rates and result in a fracture that is rather symmetrical.

In the early stages of fatigue testing, specimens will generally evolve an appreciable amount of heat. Later fissures develop at the surface eventually leading to failure. The surface of the specimen is a preferential seat of damage initiation. Corrosive effects may also assist in degradation of the structure at the surface. Corrosion is essentially a process of oxidation and under static conditions a protective oxide film is formed which tends to retard further corrosion attack. In the presence of cyclic stress the situation is quite different, since the partly protective oxide film is ruptured in every cycle allowing further attack. It is a rather simplified explanation that the microstructure at the surface of the metal is attacked by the corrosive environment causing, an easier and more rapid initiation of cracks. One of the important aspects of corrosion fatigue is that a metal having a fatigue limit in air no longer possesses one in the corrosive environment and therefore fracture can occur at relatively very low stress levels.

In commercial alloys the technical fatigue limit generally lies between 0.3 and 0.5 of the ultimate tensile stress. The fatigue strength of metals can often be enhanced by treatments which render the surface more resistant to deformation. Fracture then tends to start at the interface between the hard surface layer and the softer core. Stress raisers, such as sharp notches, corners, key ways, rivet holes and scratches can lead to an appreciable lowering of the fatigue strength of metal components. Good surface finish and corrosion protection are desirable to enhance fatigue resistance. Fatigue is basically a low temperature problem and at temperatures relatively high with respect to the melting point, fracture and hence specimen life are governed by creep.

Fractured surfaces of fatigued metals generally show a smooth and lustrous region due to the polishing effects arising from attrition at fissures. The remaining parts of the fracture surface, over which failure occurred through weakening of the specimen by the reduction of its load bearing cross-section by surface cracks and fissures, may look duller and coarser, as it is essentially caused by static fracture.

Fatigue cracks are service type discontinuities that are usually open to the surface where they start from stress concentration points Figure 1.68.

Creep

The progressive deformation of a material at constant stress is called creep. To determine the engineering creep curve of a metal, a constant load is applied to a tensile specimen maintained at a constant temperature, and the strain (extension) of the specimen is determined as a function

of time. Although the measurement of creep resistance is quite simple in principle, in practice it requires considerable laboratory equipment. The elapsed time of such tests may extend to several months, while some tests have been run for more than 10 years.

Curve A in Figure 1.69 illustrates the idealized shape of a creep curve. The slope of this curve ($d\epsilon/dt$) is referred to as the creep rate. Following an initial rapid elongation of the specimen, ϵ_0 , the creep rate decreases with time, then reaches essentially a steady state in which the creep rate changes little with time, and finally the creep rate increases rapidly with time until fracture occurs. Thus, it is natural to discuss the creep curve in terms of its three stages. It should be noted, however, that the degree to which these three stages are readily distinguishable depends strongly on the applied stress and temperature.

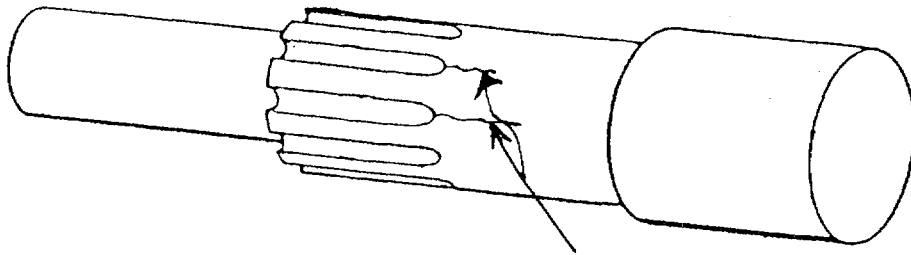

Figure 1.68: Fatigue cracks.

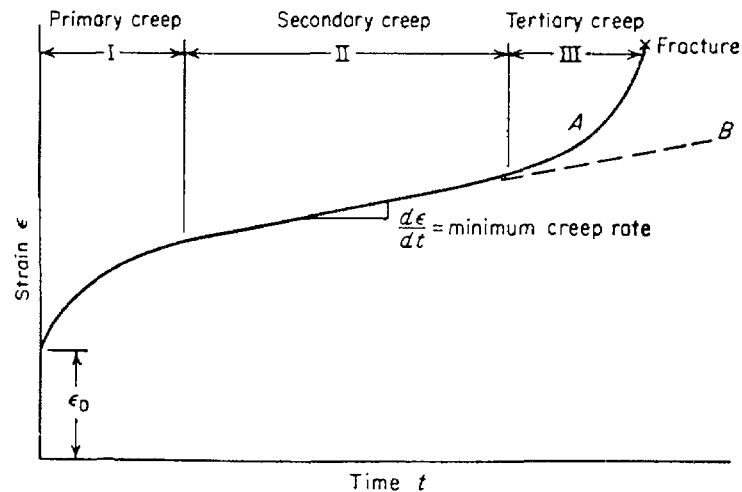

Figure 1.69: Typical creep curve showing the three steps of creep curve A, constant-load test; curve B, constant-stress test.

In making an engineering creep test, it is usual practice to maintain the load constant throughout the test. Thus, as the specimen elongates and decreases in cross-sectional area, the axial stress increases. The initial stress which was applied to the specimen is usually the reported value of stress. Methods of compensating for the change in dimensions of the specimen so as to carry out the creep test under constant-stress conditions of the specimen have been developed. When constant-stress tests are made it is found that the onset of stage III is greatly delayed. The

dashed line (curve B) shows the shape of a constant-stress creep curve. In engineering situations it is usually the load not the stress that is maintained constant, so a constant-load creep test is more important. However, fundamental studies of the mechanism of creep should be carried out under constant-stress conditions.

The first stage of creep, known as primary creep, represents a region of decreasing creep rate. Primary creep is a period of predominantly transient creep in which the creep resistance of the material increases by virtue of its own deformation. For low temperatures and stresses, as in the creep of lead at room temperature, primary creep is the predominant creep process. The second stage of creep, known also as secondary creep, is a period of nearly constant creep rate which results from a balance between the competing processes of strain hardening and recovery. For this reason, secondary creep is usually referred to as steady-state creep. The average value of the creep rate during secondary creep is called the minimum creep rate. Third-stage or tertiary creep mainly occurs in constant-load creep tests at high stresses at high temperatures. Tertiary creep occurs when there is an effective reduction in cross-sectional area either because of necking or internal void formation. Third-stage creep is often associated with metallurgical changes such as coarsening of precipitate particles, recrystallization, or diffusional changes in the phases that are present.

Wear

Wear may be defined as undesired removal of material from contacting surfaces by mechanical action. Excessive wear can be caused by continuous overload, but wear is ordinarily a slow process that is related to the friction between two surfaces. Rapid wear can often be attributed to lack of lubrication or the improper selection of material for the wear surface. Some wear is to be expected, however, and could be called normal wear. Wear is one of the most frequent causes of failure. We find normal wear in machine tooling such as carbide and high-speed tools that wear and have to be replaced or resharpened. Parts of automobiles ultimately wear until an overhaul is required. Machines are regularly inspected for worn parts, which when found are replaced; this is called preventive maintenance. Often normal wear cannot be prevented; it is simply accepted, but it can be kept to a minimum by the proper use of lubricants. Rapid wear can occur if the load distribution is concentrated in a small area because of the part design or shape. This can be altered by redesign to offer more wear surface. Speeds that are too high can increase friction considerably and cause rapid wear.

Metallic wear is a surface phenomenon, which is caused by the displacement and detachment of surface particles. All surfaces subjected to either rolling or sliding contact show some wear. In some severe cases the wear surface can become cold welded to the other surface. In fact, some metals are pressure welded together in machines, taking advantage of their tendency to be cold welded. This happens when tiny projections of metal make a direct contact on the other surface and produce friction and heat, causing them to be welded to the opposite surface if the material is soft. Metal is torn off if the material is brittle. Insufficient lubrication is usually the cause of this problem. High pressure lubricants are often used while pressing two parts together in order to prevent this sort of welding. Two steel parts such as a steel shaft and a steel bore in a gear or sprocket, if pressed together dry, will virtually always seize or weld and cause the two parts to be ruined for further use. In general, soft metals, when forced together, have a greater tendency to "cold weld" than harder metals. Two extremely hard metals even when dry will have very little tendency to weld together. For this reason, hardened steel bushings and hardened pins, are often used in earth moving machinery to avoid wear. Some soft metals when used together for bearing surfaces (for example, aluminium to aluminium) have a very great tendency to weld or seize. Among these metals there are aluminium, copper and austenitic stainless steel.

Different types of wear include abrasive wear, erosive wear, corrosive wear and surface fatigue. In abrasive wear small particles are torn off the surfaces of the metal, creating friction. Friction involving abrasive wear is sometimes used or even required in a mechanism such as on the brakes of an automobile. The materials are designed to minimize wear with the greatest amount of friction in this case. Where friction is not desired, a lubricant is normally used to provide a barrier between the two surfaces. This can be done by heavy lubricating films or lighter boundary lubrication in which there is a residual film. Erosive wear is often found in areas that are subjected to a flow of particles or gases that impinge on the metal at high velocities. Sand blasting, which is sometimes used to clean parts, utilizes this principle. Corrosive wear takes place as a result of an acid, caustic, or other corrosive medium in contact with metal parts. When lubricants become contaminated with corrosive materials, pitting can occur in such areas as machine bearings. Surface fatigue is often found on roll or ball bearing or sleeve bearings where excessive side thrust has been applied to the bearing. It is seen as a fine crack or as small pieces falling out of the surface.

Various methods are used to limit the amount of wear in the part. One of the most commonly used methods is simply to harden the part. Also, the part can be surface hardened by diffusion of a material, such as carbon or chrome, into the surface of the part. Parts can also be metallized, hard faced, or heat treated. Other methods of limiting wear are electroplating (especially the use of hard industrial chromium) and anodizing of aluminium. Some nickel plate is used, as well as rhodium, which is very hard and has high heat resistance. The oxide coating that is formed by anodizing on certain metal such as magnesium, zinc, aluminium, and their alloys is very hard and wear resistant. These oxides are porous enough to form a base for paint or stain to give it further resistance to corrosion. Some of the types of diffusion surfacing are carburizing, carbo-nitriding, cyaniding, nitriding, chromizing, and siliconizing. Chromizing consists of the introduction of chromium into the surface layers of the base metal. This is sometimes done by the use of chromium powder and lead baths in which the part is immersed at a relatively high temperature. This, of course, produces a stainless steel on the surface of low carbon steel or an iron base metal, but it may also be applied to non-ferrous material such as tungsten, molybdenum, cobalt, or nickel to improve corrosion and wear resistance. The fusion of silicon, which is called ihrigizing, consists of impregnating an iron base material with silicon. This also greatly increases wear resistance.

Hard facing is put on a metal by the use of several types of welding operations, and it is simply a hard type of metal alloy such as alloying cobalt and tungsten or tungsten carbide that produces an extremely hard surface that is very wear resistant. Metal spraying is used for the purpose of making hard wear resistant surfaces and for repairing worn surfaces.

Overload

Overload failures are usually attributed to faulty design, extra loads applied, or an unforeseen machine movement. Shock loads or loads applied above the design limit are quite often the cause of the breakdown of machinery. Although mechanical engineers always plan for a high safety factor in designs (for instance the 10 to 1 safety factor above the yield strength that is sometimes used in fasteners), the operators of machinery often tend to use machines above their design limit. Of course, this kind of over-stress is due to operator error. Inadequate design can sometimes play a part in overload failures. Improper material selection in the design of the part or improper heat treatment can cause some failures when overload is a factor. Often a machinist or welder will select a metal bar or piece for a job based upon its ultimate tensile strength rather than upon its yield point. In effect this is a design error and can ultimately result in breakdown.

Basically there are only two modes or ways in which metals can fracture under single or monotonic loads. These two modes are shear and cleavage and they differ primarily in the way

the basic metal crystal structure behaves under load. Almost all commercial solid metals are polycrystalline. Each individual crystal or grain is a structure composed of a very large number of atoms of the constituent elements. These atoms are arranged in cells within each crystal in a regular, repetitive three-dimensional pattern. Adjacent cells share the corner atoms and their positions are balanced by electrical forces of attraction and repulsion. Applied forces can cause distortion of the cells. Shear deformation represents a sliding action on planes of atoms in crystals. In a polycrystalline metal slight deformation causes no permanent change in shape, it is called elastic deformation. That is, the metal returns to its original size and shape, like a spring, after being unloaded. If a greater load is imposed, permanent or plastic deformation occurs because of irreversible slip between certain planes of atoms that make up the crystal structure. If the applied load or force is continued, the shear deformation causes tiny microvoids to form in the most highly stressed region. These tiny voids soon interconnect and form fracture surfaces. The cleavage mode of separation of the cell is different. In this case separation occurs suddenly between one face of the cell and the mating face of the adjacent cell without any deformation being present.

Fracture will originate whenever the local stress, i.e. load per unit cross-sectional area, first exceeds the local strength. This location will vary depending upon the strength of the metal and the applied stress. When a shaft or similar shape is pulled by tensile force it becomes longer and narrower. For ductile metals the shear strength is the weak link and these metals fail through the shear mode. These metals fail when shear stress exceeds the shear strength. In the case of brittle metals, these fail because the tensile stress exceeds the tensile strength. Brittle metals always have a fracture that is perpendicular to the tensile stress and little or no deformation because fracture takes place before the metal can deform plastically as ductile metals do.

When a cylinder is loaded in axial compression, a ductile metal becomes shorter and thicker. In short it bulges when squeezed by the compressive force and there is no fracture. A brittle metal in pure compression will fracture parallel to the length of the cylinder.

Brittle and ductile fracture

Fracture preceded by a significant amount of plastic deformation is known as ductile fracture, otherwise it is brittle fracture. Brittle fracture occurs, when plastic flow is inhibited either by the effective locking of atomic dislocations by precipitates or elements or by the pre-existence or formation of cracks and imperfections acting as local stress raisers in the material. All materials can be embrittled if the temperature is lowered sufficiently. Glass, sealing wax, germanium, silicon and other materials though ductile at temperatures close to their melting point are brittle at ordinary temperatures. In most materials the brittle strength, defined as the maximum tensile stress withstood without the occurrence of brittle fracture, is low compared with the ideal strength the fault-free material would be expected to exhibit. The source of brittle fracture is therefore to be sought in the presence of structural defects.

As has already been mentioned brittle metals always have a fracture that is perpendicular to the tensile stress and have little or no deformation because fracture takes place before the metal can deform plastically. Thus a tensile fracture of a brittle metal has a fracture plane that is essentially straight across. It also usually has a characteristic bright sparkling appearance when freshly fractured.

The pattern of a break can often reveal how the failure was precipitated. For example, if the break was caused by a sudden shock load such as an explosion, there are usually chevron-shaped formations present that point to the origin of fracture. When a stress concentration is present, such as a weld on a structure that is subject to a sudden overload, the fracture is usually brittle across the entire break, showing crystals, striations, and wave fronts. Brittle fractures are often

intergranular (along the grain boundaries); this gives the fracture surface a rock candy appearance at high magnification. When grain boundaries are weakened by corrosion, hydrogen, heat damage, or impurities, the brittle fracture may be intergranular. Brittle failures can also be transgranular (through the grains): this is called cleavage.

Cleavage fracture is confined to certain crystallographic planes that are found in body centred cubic or hexagonal close-packed crystal structures. For the most part, metals having other crystalline unit structures do not fail by cleavage unless it is by stress-corrosion cracking or by corrosion fatigue. Cleavage should normally have a flat, smooth surface; however, because metals are polycrystalline with the fracture path randomly oriented through the grains and because of certain imperfections, certain patterns are formed on the surface.

Small quantities of hydrogen have a great effect on the ductility of some metals. Hydrogen can get into steels when they are heated in an atmosphere or a material containing hydrogen, such as during pickling or cleaning operations, electroplating, cold working, welding in the presence of hydrogen-bearing compounds, or the steel-making process itself. There is a noticeable embrittling effect in steels containing hydrogen. This can be detected in tensile tests and seen in the plastic region of the stress-strain diagram showing a loss in ductility. Electroplating of many parts is required because of their service environment to prevent corrosion failure. Steel may be contaminated by electroplating materials that are commonly used for cleaning or pickling operations. These materials cause hydrogen embrittlement by charging the material with hydrogen. Mono-atomic hydrogen is produced by most pickling or plating operations at the metal-liquid interface, and it seems that single hydrogen atoms can readily diffuse into the metal. Preventive measures can be taken to reduce this accumulation of hydrogen gas on the surface of the metal.

A frequent source of hydrogen embrittlement is found in the welding process. Welding operations in which hydrogen-bearing compounds such as oil, grease, paint, or water are present, are capable of infusing hydrogen into the molten metal, thus embrittling the weld zone. Special shielding methods are often used that help to reduce the amount of hydrogen absorption. One effective method of removing hydrogen is a baking treatment in which the part, or in some cases the welding rod, is heated for long periods of time at temperatures of 121 to 204°C. This treatment promotes the escape of hydrogen from the metal and restores the ductility.

Stress raisers such as notches on the surface of a material have a weakening effect and cause embrittlement. A classical example is provided by the internal notches due to graphite flakes in cast irons. The flakes embrittle the irons in tension. Therefore in structural applications cast irons are most usefully employed under compressive loads. Their brittle strength and toughness can, however, be increased appreciably if the graphite is allowed to form in spheroidal rather than flaky form. This can be done by alloying the melt, for example, with magnesium.

1.4.3. Concepts of rupture development in metals

Most of the ideas related to the development of defects in materials have already been discussed in Section 1.4.2. Rupture occurs when the size of these defects, specially cracks, reaches a certain critical size.

1.5. Quality and standardization

1.5.1. Quality

Quality of an industrial product does not mean the best or excellent. On the other hand it is defined as the fitness of the product to do the job required of it by the user. It may also be said to be the ability of the product to meet the design specifications which usually are set keeping in

view the purpose and the use to which the product is expected or intended to be put. As stated earlier it would be better to set or define an optimum quality level for a product rather than trying to make it of best possible quality which will unnecessarily make the product more expensive which may not be acceptable to the customer.

In a generalized way, the typical characteristics of industrial products which help in defining and fixing its specifications and quality are chemical composition, metallurgical structure, shape and design, physical properties of strength and toughness, appearance, environmental properties, i.e. response to service conditions and presence or otherwise of internal defects. These requirements should be met within the specified tolerances. The cost, of course, is an important component. The ability of an organization to meet quality criteria in production of goods or services will ultimately bear on the profitability and survivability of that organization. If it cannot produce goods to the customer's requirements, it cannot compete except under very abnormal and short-term circumstances. However, if the customer's requirements are impossible to meet, or difficult to meet within the financial constraints imposed, the solution may very well be to redefine the requirement. Insistence on an unnecessarily high performance requirement may be completely impractical. In every industry, in every corner of the world, striving for quality has become a popular activity, applied with more or less success depending on the organization and its level of commitment. It should be recognized that quality is not an accident, rather, it should be planned. Quality cannot be inspected into a product after it is made. Instead, the inspection criteria are only to verify that quality criteria are being achieved. The complexity of management of quality within an organization depends on the complexity of the product and the process as well as on the performance criterion. Once a customer's requirement is accepted, quality is the producer's responsibility.

1.5.2. Quality control

Quality control can be defined as the controls applied at each manufacturing stage to consistently produce a quality product or in another way it is said to be the applications of operational techniques and activities which sustain quality of a product or service that will satisfy given needs, also the use of such techniques and activities. The concept of total quality control is defined as a system for defining, controlling and integrating all company activities which enable economic production of goods or services that will give full customer satisfaction. The word "control" represents a management tool with four basic steps, namely, setting quality standards, checking conformance with the standards, acting when the standards are not met and assessing the need for changes in the standards.

1.5.3. Quality assurance

As the name suggests quality assurance is the taking of all those planned and systematic actions necessary to assure that the item is being produced to optimum quality level and it will, with adequate confidence, perform satisfactorily in service.

Quality assurance is aimed at doing things right the first time and involves a continuing evaluation of the adequacy and effectiveness of the overall quality control programme with a view to having corrective measures initiated where necessary. For a specific product or service this involves verification audits and evaluation of quality factors that affect the production or use of the product or service. Quality assurance is quality control of the quality control system.

1.5.4. Examination and testing

Examination and testing are those quality control functions which are carried out, during the fabrication of an industrial product, by quality persons who are employees of the manufacturer. Testing may also be defined as the physical performance of operations (tests) to

determine quantitative measures of certain properties. Most of the non-destructive testing is performed under this heading.

1.5.5. Inspection

Inspections are the quality control functions which are carried out, during the fabrication of an industrial product by an authorized inspector. They include measuring, examining, testing, gauging or otherwise comparing the findings with applicable requirements. An authorized inspector is a person who is not the employee of the manufacturer of an industrial product but who is properly qualified and has the authority to verify to his satisfaction that all examinations specified in the construction code of the product have been made to the requirements of the referencing section of the construction code.

1.5.6. Process of standardization

The objective of most non-destructive testing methods is to detect internal defects with respect to their nature, size and location. This is done by different methods depending upon their inherent capability or sensitivity to flaw detection. A method is said to have a good or high sensitivity of flaw detection when it can detect relatively smaller flaws and vice versa. The sensitivity of flaw detection for different NDT methods depends upon a number of variable factors. Now imagine that someone is to perform, say, ultrasonic testing of circumferential welds in steel pipes of 50 cm diameter having a 10 cm wall thickness. He will undertake extensive experimentation to establish the values of different variable factors to evolve a method which gives reliable and reproducible results of desired sensitivity. This person is wise enough to carefully write down his procedure for testing of pipe welds. If someone else anywhere had a problem of ultrasonically inspecting pipe welds of similar specifications, there would be two options open to him. First he could undertake all the extensive experimentation involving lot of time, effort and money, and second he could request the first person and use his procedure which was known to be giving reliable and reproducible results of desired sensitivity. Many persons in one city, country or different countries could use this method as a guide or recommended procedure or practice. These many persons might sometimes get together in a meeting, conference or a committee to exchange their views and experience related to this procedure. They might mutually agree on a standard procedure for ultrasonic testing of circumferential welds in steel pipes of 50 cm diameter and 10 cm wall thickness and recommend it to the standard issuing authority of their country to issue this as a national standard. Some such standards issued by the standard issuing authority of the country could be taken up by the legislature or parliament of the country and their use made obligatory by law. This briefly explains in very simple terms the otherwise complex and time consuming process of formulation and issuance of codes and standards.

1.5.7. Guides and recommended practices

Guides and recommended practices are standards that are offered primarily as aids to the user. They use verbs such as “should” and “may” because their use is usually optional. However, if these documents are referenced by codes or contractual agreements, their use may become mandatory. If the codes or agreements contain non-mandatory sections or appendices, the use of referenced guides and recommended practices by them, are at the user’s discretion.

1.5.8. Standards

Standards are documents that govern and guide the various activities occurring during the production of an industrial product. Standards describe the technical requirements for a material, process, product, system or service. They also indicate as appropriate, the procedures, methods, equipment or tests to determine that the requirements have been met.

1.5.9. Codes and specifications

Codes and specifications are similar types of standards that use the verbs “shall” or “will” to indicate the mandatory use of certain materials or actions or both. Codes differ from specifications in that their use is mandated with the force of law by governmental jurisdiction. The use of specifications becomes mandatory only when they are referenced by codes or contractual documents. A prime example of codes is the ASME boiler and pressure vessel code which is a set of standards that assure the safe design, construction and testing of boilers and pressure vessels.

1.5.10. Procedure

In non-destructive testing, a procedure is an orderly sequence of rules or instructions which describe in detailed terms where, how and in which sequence an NDT method should be applied to a production.

1.5.11. Protocols

The rules, formalities, etc., of any procedure, group, etc. (The Concise Oxford Dictionary 8th Edition).

1.5.12. Report

A report of a non-destructive examination or of testing is a document which includes all the necessary information required to be able to:

- (i) Take decisions on the acceptance of the defects by the examination.
- (ii) Facilitate repairs of unacceptable defects.
- (iii) Permit the examination or testing to be repeated.

1.5.13. Records

Records are documents which will give, at any time in the future, the following information about a non-destructive testing examination, (i) the procedure used to carry out the examination, (ii) the data recording and data analyzing techniques used, and (iii) the results of the examination.

1.5.14. Development of a quality system

Quality system, also called quality assurance system, has already been defined in Section 1.5.3. It is an effective method of attaining and maintaining the desired quality standards. It is based on the fact that quality is the responsibility of the entire organization and that inspection alone does not assure quality or more precisely, does not assure conformance to requirements of the control or customer order. This applies not only to complex products such as satellites or nuclear submarines, but also to simple products such as nails or pipe fittings. Regardless of the product or service involved, the essentials of an effective quality assurance system include:

- (i) Independence of the quality assurance department from the design and production departments.
- (ii) Standards of quality that reflect both the needs of the customer and the characteristics of the manufacturing process.
- (iii) Written procedures that cover all phases of design, production, inspection, installation and service, with a programme for continuous review and update of these procedures.

- (iv) Control of the flow of documents such as order entry, order changes, specifications, drawings, route slips, inspection tickets and shipping papers.
- (v) Methods for maintenance of part identity which must establish traceability through the process.
- (vi) Methods for timely detection and segregation of non-conforming material which must also include programmes for corrective action.
- (vii) Schedules for periodic calibration of inspection equipment.
- (viii) Schedules for retaining important records.
- (ix) Programmes for training and qualification of key production and inspection personnel.
- (x) Systems for control of specifications incorporated into purchase order; for control of the quality of purchased goods and for appropriate inspection of purchased goods.
- (xi) Systems for control of manufacturing, assembly and packaging processes, including inspection at key points in the process flow.
- (xii) A system for periodic audit of any or all of the above by persons having no direct responsibility in the area being audited.

The quality assurance system is an evaluation or audit of each one of these subsystems to determine how effectively the functions are being performed. Evaluations are usually conducted each year to determine which elements and subsystems need improvement. The overall rating provides a comparison with past performance or with other plants of a multiplant corporation. These subsystems are briefly described in the following sections.

Independence of quality assurance department

Responsibility for the development, operation and monitoring of an effective quality assurance programme in a plant usually rests with the quality assurance manager. Companies having several plants may have a corporate quality assurance department that reviews and coordinates the system for the entire organization. To be effective this should be an independently staffed department that reports directly to an upper level manager such as general manager, vice president or president. The quality assurance department should be free to devise and recommend specific systems and procedures and require corrective action at their discretion.

Establishment of quality standards

No single quality level is necessary or economically desirable for universal use; the quality requirements of a paper clip are obviously quite different from those of a nuclear reactor. Many professional groups, trade associations and government agencies have established national codes and standards. However these codes and standards generally cover broad requirements, whereas a set of detailed rules for each product or class of products is required for the control of quality.

In most plants it is the responsibility of the quality assurance manager to interpret national codes and standards in terms of the purchase order and from these to devise process rules uniquely suited to the specific products and manufacturing methods used in that particular plant. The set of process rules thus devised may be known by various names: in these training notes it will be called an 'operating practice description'. There may be thousands of operating plant descriptions in plant files, each varying from the others as dictated by code or customer requirements, limits on chemical composition or mechanical properties, or other special characteristics. Large plants may have computerized storage systems permitting immediate retrieval of part or all of the operating practice descriptions at key locations throughout the plant.

Written procedures

Written procedures are of prime importance in quality assurance. Oral instructions can be inadequately or incorrectly given and thus misunderstood and incorrectly followed. Clear and concise written instructions minimize the likelihood of misinterpretation. Vague generalizations that do neither assign specific responsibilities nor determine accountability in case of error must be avoided. For instance, procedures should be specific regarding the type and form of inspection records, the identity of the individual who keeps the records and where the records are kept. Similarly, a calibration procedure should not call for calibration at 'periodic intervals' but should specify maximum intervals between calibrations. Depending on the type of equipment, calibration may be performed at intervals ranging from a few hours to a year or more.

Control of document flow

The original purchase order, which is often less than one page in length, may generate hundreds of other working papers before the ordered material or part is shipped. All paperwork must be accurate and must reach each work station on time. In some industries where there may be an average of two or more specifications or drawing changes per order, an effective system of material tracking that is separate and distinct from material identification is necessary.

Control of document flow places direct responsibility on departments not usually associated with quality control. The sales office (which is responsible for entry of the customer order), the production planning group (which is responsible for scheduling work and tracking material) and the accounting department (which is responsible for billing and shipping) are all involved. Many large plants have computerized order systems, the heart of which is an 'active order file'. This computer file receives periodic inputs to update information on specifications, drawings, material sizes, shop operations, shipping and routing. In turn this file may be accessible from various terminals in the sales office, home office or plant, when information is needed on material location, order status and the like.

Maintaining identity and traceability of materials

In high speed manufacturing operations, particularly those involving hot work, identity markings on the raw material (such as paint mark, stencils or stamps) are usually destroyed during processing. In such instances, procedures must be devised for maintaining identity not by marking alone but also by location and count. These procedures sometimes must provide for traceability of individual units of products by a method suitable for the product and process and must include any additional identity that the customer may require. Ultimately both producer and customer must be confident that the goods actually delivered are described accurately in the shipping papers, test reports and certificates of compliance. This confidence is of great importance in certain applications in the aerospace and nuclear industries.

Non-conforming material and corrective action

A system for detection and segregation of non-conforming material requires:

- (a) Written inspection instructions that can be clearly understood.
- (b) Identified, segregated holding areas for parts that have been rejected.
- (c) A structured group (sometimes called a materials review board) to evaluate rejected material, make final judgement on its fitness for use, decide what is to be done with non-conforming material and prescribe action for the cause of rejection.

In many instances rejected parts are only slightly out of tolerance and their usefulness is not impaired. Even so, all decisions of a materials review board to accept non-conforming material must be unanimous. In the absence of unanimity, the problem may be referred to top management for a decision based on overall business judgement. In some companies, the authority of the materials review board is limited to merely deciding whether or not non-conforming material is fit for use. However, in many companies the board also determines what is to be done with non-conforming lots; whether they are to be shipped 'as is', sorted, repaired or scrapped, and fixes the accountability for incurred losses. When corrective action is recommended by a materials review board, it is usually systems oriented, that is, intended to prevent recurrence of the non-conformity by avoiding its cause. In instances where a lot has been rejected because the acceptance number for a sampling plan has been exceeded, decisions concerning disposition of the lot often are made on the basis of costs, the solution that results in the least total cost to both producer and customer is adopted. Sometimes, material that is slightly out of tolerance and therefore not fit for use by one customer may meet the specifications of another customer.

Calibration of equipment

The quality assurance system must recognize that the accuracy and repeatability of measuring and testing equipment may be affected by continued use; maximum intervals between calibrations should be specified in the written quality assurance procedures. Except perhaps for small hand instruments such as micrometers, each testing machine or instrument should be plainly labelled with the last date of calibration. Calibration standards should be traceable to recognized industry or national standards of measurement. It is also desirable to maintain a central file of calibration records for each plant or department.

Retention of records

A quality assurance system must designate which records are to be retained and must set down minimum time periods for retention of such records. It is usual for important documents to be retained for 25 years or more; the nuclear industry is required to maintain records for 40 years. Retention time, however, should be consistent with real needs as dictated by projected lifetime of products or by legal requirements. Besides satisfying certain contractual or other legal requirements, retained records can provide important cost benefits to both producer and customer. In one instance, extensive and costly testing of a 50 years old structure prior to repair was avoided when the fabricator was able to produce original drawing and material test reports.

Personnel training and qualification

National codes exist for the qualification of certain specialized workers, for instance welders and inspectors. When applicable, codes should be incorporated as minimum requirements for training and qualification of key personnel. All of these, however, must be supplemented by local written procedures for both on-the-job and classroom training. Quality assurance management must reduce complex procedures to the simplest form that will permit a trainee to understand exactly what the job is and how it is to be performed.

Control of purchased material

All specifications and orders for outside purchases of material whose performance may affect product quality should be subject to approval by quality assurance management. Inspection of incoming material should be subject to approval by quality assurance management. Inspection of incoming material should be incorporated into the quality assurance programme. The main purpose of receiving inspection is to check for failures of vendor quality programmes, but receiving inspection should not be expected to compensate for poor quality control by vendors.

The purchaser should evaluate and periodically audit the quality assurance system of each major supplier to make sure that the purchased material can be expected to have the specified level of quality.

Manufacturing, assembly and packaging

All manufacturing, assembly and packaging processes should be controlled to ensure attainment of the finished product of the right quality at the time of its reaching the customer. Design drawings and the processes of manufacturing and assembly should be assessed whether appropriate methods of adequate capability and sensitivity are being applied and whether the results being obtained are reliable and reproducible or not. The tests should be applied at appropriate stages during manufacture and all test reports should be properly signed by authorized persons. All manufacturing, testing, assembly and packing should be done according to verifiable written procedures.

Quality audit

Quality audit is an independent evaluation of various aspects of quality performance to provide information with respect to that performance. Quality audits are usually made by companies to evaluate their own quality performance, by buyers to evaluate the performance of their vendors, by regulatory agencies to evaluate the performance of organizations which they are assigned to regulate.

Purpose of audit is to provide assurance that:

- Procedures for attaining quality are such that, if followed, the intended quality will be obtained.
- Products are fit for use and safe for the user.
- Laws and regulations are being followed.
- There is conformance to specifications.
- Written procedures are adequate and being followed.
- The data system is able to provide adequate information on quality.
- Corrective action is being taken with respect to deficiencies.
- Opportunities for improvements are identified.

For an internal quality audit typically the organization is divided up into its component parts and each area is audited. The time taken depends on the size of the organization. For a small NDT organization one could audit the following:

- Documentation of NDT procedures.
- Control of stores.
- Receipt of job instructions.
- Purchasing of equipment and accessories.
- Maintenance of equipment and accessories.
- Calibration of equipment.
- Contract administration.
- Safety.

- Accounting.
- Office administration, e.g. wages, leave, superannuation.
- Organizational structure.
- Research and development.
- Reports and records.

A periodic audit of quality of the system performance against written standard is needed to detect corner-cutting, non-compliance and intentional violations of established quality procedures. To be as unbiased as possible, such audits should be performed by persons not having responsibility in the area being audited. In companies having multiple plants, each individual plant may conduct its own internal audit, but in addition should be subject to audit by corporate staff personnel. The most important activities of corporate staff aside from auditing are review of the quality system with the highest level of plant management and follow up to approve corrective action for any discrepancies found during an audit.

Periodic review of the quality assurance system and reaffirmation of quality objectives by top management should be part of company policy. This will in part ensure long range viability of the business enterprise.

2. PHYSICAL PRINCIPLES OF THE TEST (PT)

2.1. General description of the method

Penetrant inspection consists essentially of the following sequence of operations:

- (1) The surface of components to be inspected is prepared by cleaning, creating a clean dry surface.
- (2) Penetrant is applied to the prepared surface to be inspected.
- (3) A period of time is allowed for it to enter any discontinuity open to that surface.
- (4) The excess penetrant is removed in such a manner that will ensure retention of penetrant inside of the discontinuity.
- (5) A developer agent is applied to draw the penetrant liquid from the discontinuities out to the surface and thereby give an enhanced indication of such discontinuities.
- (6) The discontinuities are then visually examined and assessed under appropriate viewing conditions.
- (7) The part is then cleaned and, as necessary, a corrosion preventative is applied.

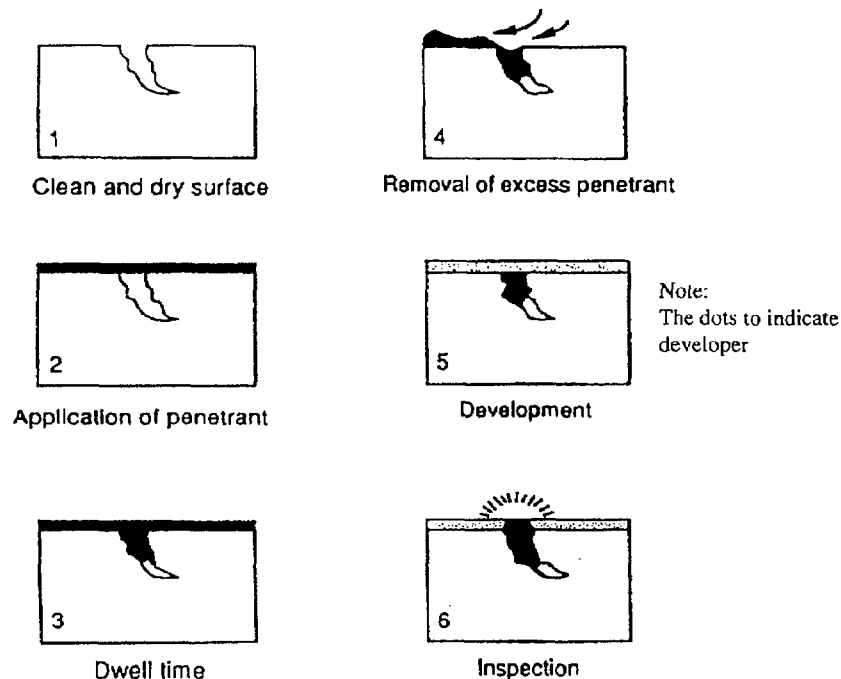

Fig 2.1: Mechanism of penetrant flaw detection.

2.2. Properties of liquid penetrants

2.2.1. Viscosity

Liquids have the ability to flow because molecules of the liquid can slide over each other. The resistance of liquid to its flow is called viscosity Figure 2.2. In other words, viscosity of a liquid is a measure of its internal resistance to flow.

The resistance to flow is because of the internal friction among the layers of molecules. Liquids which flow very slowly like honey or glycerine, have high viscosities as compared to ether and water having low viscosities.

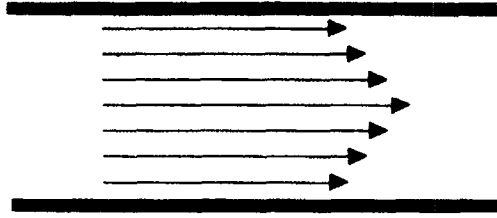

Figure 2.2: Viscosity of a liquid. The velocity of flow of liquid nearer to the sides of tube is less than the velocity of flow in the centre of tube.

If a liquid flowing in a tube is considered as made up of a series of layers, the layer of the liquid in contact with the walls of the tube remains stationary. The layer in the centre of the tube has highest velocity. Each layer exerts a drag on the next layer and causes resistance to flow. High viscosity penetrants have a disadvantage of a slower rate of penetration; conversely too-low viscosity penetrants can drain away too rapidly and have a tendency to drain out of shallow defects.

The Newton's law of viscous flow.

$$F = \eta S \, dv/dr. \quad (1)$$

The proportionality constant η is the co-efficient of viscosity which is defined as the force required per unit area to maintain a unit difference of velocity between the two adjacent layers which are a unit distance apart. The dimensions of η are $(\text{mass}) (\text{length})^{-1} (\text{time})^{-1}$. The SI unit is $\text{kg. m}^{-1} \text{s}^{-1}$. The C.G.S. unit called the poise (p) is equal to 1/10th of SI unit of viscosity.

The reciprocal of co-efficient of viscosity is called Fluidity and it is given by the symbol ϕ (Phi).

$$\text{Fluidity} = 1/\eta \quad (2)$$

Fluidity is a measure of the ease with which a liquid can flow.

Now in case of liquid penetrants viscosity does have an important practical consideration in their choice. It is an important factor in determining the speed with which a penetrant will enter the defect. Fluidity is the reciprocal of viscosity and thus a viscous penetrant will penetrate or emerge more slowly than a less viscous one. If on the other hand the viscosity is too low, the excess penetrant on the surface of the penetrant will drain away too quickly and not leave a pool of penetrant to act as a reservoir to top up the defect as penetration takes place. Furthermore the 'thin' penetrants can also be more easily washed out of defects during cleaning.

2.2.2. Surface tension

Surface tension in a liquid is an example of cohesive force, where the molecules are attracted to like molecules. The cohesive force tends to bind them together, having affinity for each other. Two examples are water and mercury. When either of these liquids is spilled, they tend to form spherical shapes, the cohesive force binding them together by surface tension.

Surface tension is one of the two most important properties which determines whether a liquid makes a good penetrant but is not in itself the controlling factor. The term surface tension can be described as force per unit length on an imaginary line drawn on the surface of a liquid. The formation of penetrant indication on development is a reverse capillary action. The rise of

liquid in capillary tubes when dipped in it is due to surface tension and its wetting ability. The value of surface tension can be calculated by the formula:

$$T = g \rho r/2 (h + r/3) \quad (3)$$

Where:

g = acceleration due to gravity = 980 cm/sec²

ρ = density of the liquid (gram/cm³)

h = height of liquid rise in capillary tube

r = radius of the capillary tube (cm)

T = surface tension (dynes/cm).

The surface tension of the liquids is affected by change in temperature, density of liquid and nature of surface in contact. With rise in temperature surface tension of a liquid decreases. At a temperature close to the critical temperature, the surface tension becomes very small as the greater thermal agitation reduces the attractive forces which are pulling the molecules inward. Generally, a high surface tension is desirable, but water which although has a high surface tension in its pure form is not a good penetrant due to its poor wetting ability. The wetting ability can however be improved by adding a wetting agent which reduces the contact angle drastically, and even though surface tension is also reduced the resulting combination can make water a good penetrant.

2.2.3. *Angle of contact between liquid and solid*

Angle of contact refer to Figure 2.3 determines the wetting ability of the liquid. It is defined as the angle made between the surface of the liquid and the point of contact as the liquid advanced along the surface. The magnitude of contact angle determines the penetrativeness of fluids. Liquids with high contact angle make them poor penetrants.

Water though has a high surface tension but due to high contact angle is a poor penetrant. The contact angle between a liquid and surface varies widely with the material, surface roughness, cleanliness, etc. of the surface under test.

2.2.4. *Capillarity*

The mechanism of entry and coming out of fine discontinuities is due to capillary forces. The capillary pressure is a function of the surface tension of the liquid and its ability to wet the surface of the tube. A liquid will rise to a considerable extent if the upper end of the tube is open and to a lesser extent if the upper end is closed. It would seem that a sealed tube is similar to a fine crack, and that some air will be trapped. For a given penetrant and crack-like defect the pressure developed may be expressed by the formula:

$$P = 2T \cos \theta/w \quad (4)$$

Where:

T = surface tension

θ = contact angle between the liquid and crack surface

w = width of the crack.

It is evident from the above relation that larger values of surface tension and smaller contact angles or crack widths, will increase this pressure. It is also possible at these pressures that the entrapped air may in time dissolve into the penetrant and diffuse out to surface to escape. It has been shown that a good penetrant can enter an opening 5 micro inches wide (127 μ m).

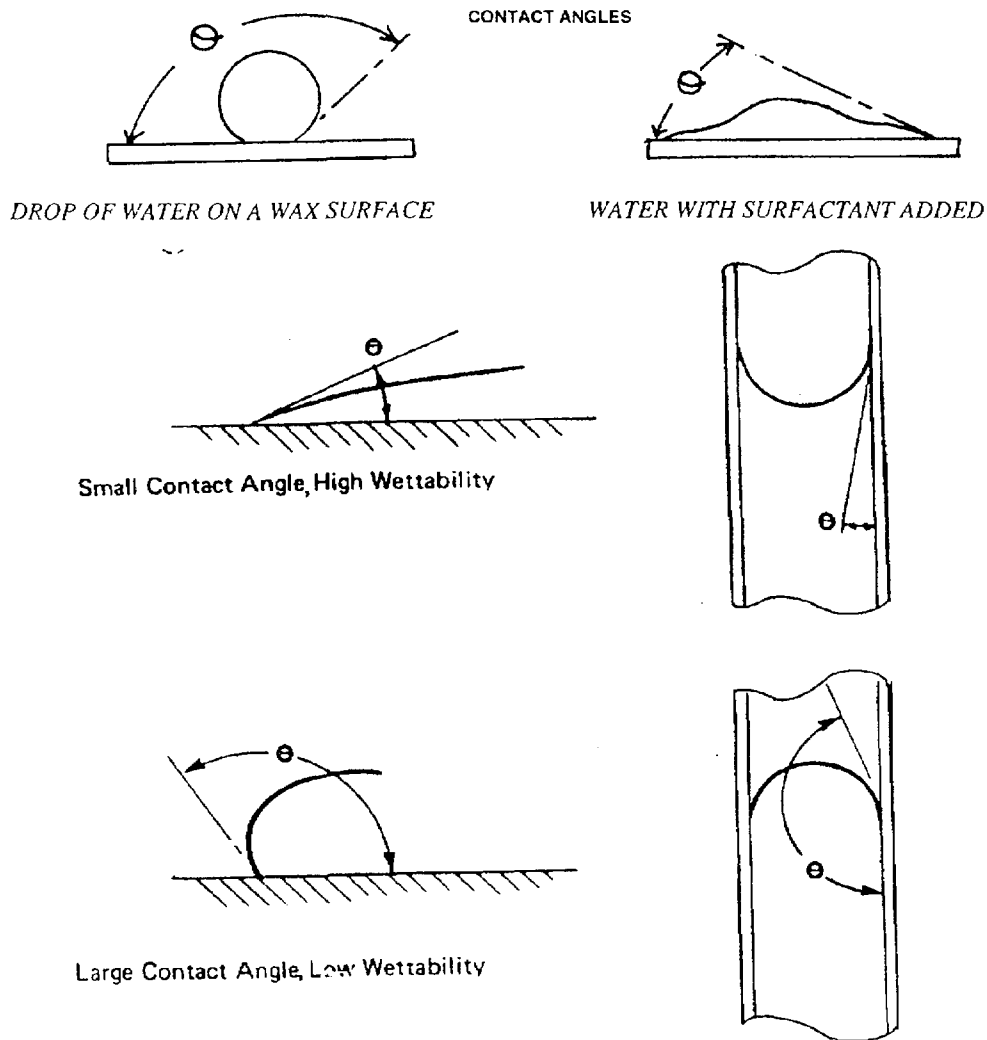

Figure 2.3: Wetting ability, a function of contact angle.

2.3. Behaviour of liquid penetrants

2.3.1. Wettability

Wetting ability has an important effect on overall performance of the penetrant. A penetrant that has good wetting properties will spread completely over the surface of the treated part. On the other hand, a liquid of poor wetting characteristics will pull back on itself, leaving areas of the test surface completely devoid of penetrant. When this occurs, defects which may be present in the uncovered areas will not be shown since there is no indicating material available to enter them. Wetting ability refers to the angle of contact with the surface, e.g. water is an excellent solvent, with a very high surface tension. However, the addition of a surfactant can decrease the contact angle, improving its penetrating properties while still maintaining its solvent properties.

2.3.2. Penetrability

A good penetrant is the one which has a high penetrativeness. Parameters such as viscosity and wetting ability have an influence on the liquid to be a good or bad penetrant. Low viscosity materials run off parts more rapidly and may not remain on the test surface long enough to permit complete penetration. On the other hand, high-viscosity materials may be dragged out in such quantity as to be non-economical in use.

2.3.3. Washability

An important requirement for a good penetrant is its suitable removability from the surface of the part after the penetration into defects has taken place. This implies that the penetrant must be soluble in the solvent, remover, or in water to achieve this. Removal performance is very important since surplus penetrant must be removed from the surface of the part or the entire part will have a high background/fluorescence. This will greatly reduce the contrast between the defect indication and the rest of the surface area. On the other hand, if the penetrant can be removed too easily, it will be washed out of the defects. This will cause greatly reduced flaw detection sensitivity capability, particularly for the shallower discontinuities.

2.3.4. Retention and bleeding

A penetrant should possess the ability to penetrate readily into fine and relatively coarse openings and resist cleaning out of them. Similarly, it should have tendency to spread or bleed out of discontinuities on development. The process of bleeding can be described as to be a reverse capillary action. The developer acts as blotter helping the penetrant sitting in fine surface-open discontinuities to come up to the surface to form an indication. The rate and extent of the action associated with capillary depends upon such factors as forces of cohesion and adhesion, surface tension and viscosity. Liquid penetrants in non-destructive testing should have low surface tension and high capillarity.

2.3.5. Influence of surface state of the sample, the contamination and temperature

The principle of all penetrant processes is that the penetrant must enter the surface openings of discontinuities if it is later to identify them. Therefore unless the part is clean and free from foreign materials that may cover the discontinuities, or perhaps later confuse the indications, reliable inspection cannot be made. Scale and rust as contaminations have to be got rid of from the surface of the test part. They tend to cover defects or may cause confusing indications by trapping and holding penetrant on the surface of the part. For soft materials, the methods such as shot blasting, sandblasting, emery cloth, wire brushing or metal scraping are not recommended as they may cover the defects by peening or cold working the surface. Solid contamination such as carbon, varnish, paints, and similar materials should be removed by vapour blast, chemical dip and other acceptable methods. Oil and grease on surface should also be completely removed from the test part as many oils are somewhat fluorescent and are also good penetrants. They can thus fill the discontinuities and also produce false indications due to fluorescence under black light.

Acids and chromates should also not be left on the surface of the test parts or within the surface discontinuities because these chemicals adversely affect some penetrants. It is essential that the parts pre-cleaned for inspection should be thoroughly dry. Any liquid residue will hinder the entrance of the penetrant. Drying may be accomplished by drying the parts in drying ovens with infrared lamps, forced hot air, or exposure to ambient temperature. Parts' temperature should not exceed 125 °F (52 °C) prior to the application of the penetrant. The requirement of inspection to be carried out within 16 °C–52 °C is mainly because of the following facts:

- (a) In case of fluorescent dyes, their fluorescence is reduced by heat. Resistance to heat is therefore, of greater importance. This is so, as loss of fluorescence mean loss of sensitivity to fine or any defect.
- (b) In situations where colour contrast penetrant with red dye are shipped or stored at 0 °F or low, there may occur possibility of the separation of the dye out of solution. This may reduce the brilliance of the penetrant due to loss of dye content. If this occurs then warming of the can up to (70 °F or above) and agitation can help in re-dissolving the dye.

- (c) At higher temperatures the volatile constituents of the carrier fluid may evaporate significantly, thus there can be no fluid left to make the tracer dye get into the defects as its carrier.

2.4. Solutions and dispersions

2.4.1. Solvents

The primary purpose of the solvent removers is removal of excess (non-water-soluble) liquid penetrant prior to application of the developer. Solvent removers are often used also for pre-cleaning and for post-cleaning of test objects to remove penetrant processing residues.

Solvents are also used as carrier fluid for colour and fluorescent type tracer dyes of the penetrant. In such penetrants, dyes are selected to be soluble in the solvent used as their carrier fluid. Such penetrants are thus easily removable from the surface of the test part during the removal process of excess penetrant by the particular solvent used as a cleaner. Usually such cleaners are organic compounds.

The high sensitivity visible dye penetrants contain maximum amount of dark red dye suspended in the vehicle without precipitation. Similarly, the sensitivity of fluorescent penetrant is influenced by the dye concentration and colour shade. It is thus essential for the carrier or vehicle to dissolve the dye and be its solvent.

2.4.2. Dispersive agents

The liquids used in the penetrant making should also possess the ability to distribute the dye evenly and completely over the surface to be inspected and carry it to the defects present on the test surface. This ability is in addition to the above mentioned characteristic of the penetrant which should be of strong wetting ability to be a strong dispersive agent. The carrier material with good wetting ability will help spread the penetrant evenly and smoothly over the surface even in the presence of surface contamination.

2.4.3. Emulsifiers

Emulsifier is a liquid that combines with an oily penetrant to make the penetrant water washable. In penetrants which are water-washable, this emulsifier is already incorporated into them. If washing of parts becomes noticeably difficult, the emulsifier should immediately be checked. The most possible cause of deterioration of emulsifier is its contamination with water. The loss of effectiveness in removing excessive penetrant is generally accompanied by a change in appearance or physical properties. The low-tolerance (water-tolerance) materials generally become viscous or gel completely. The high tolerance emulsifiers may become cloudy or show a tendency to thicken. The emulsifiers are essentially of two types such as oil based (lipophilic) and water-based (hydrophilic).

Lipophilic emulsifier

Lipophilic emulsifiers have three basic properties that must be balanced to assure the proper washing characteristics. The emulsifier must diffuse or interact with the penetrant oil at a somewhat slow rate to allow for handling time during processing and to provide time so that the washing of a range of surface roughness' can be controlled. The three properties of emulsifiers that control the washing characteristics are (1) activity, (2) viscosity, and (3) water tolerance. These properties must be factored against the characteristics of the oil base of the penetrant. If the penetrant vehicle is highly insoluble in water, a more active emulsifier is needed. A highly active

emulsifier with a low viscosity can be adjusted by blending with a more viscous emulsifier to provide the desired washing characteristics.

Emulsifier activity is defined as the rate that the emulsifier interacts with the penetrant sufficiently in order to be removed with water. The interaction is related to the ability of the emulsifier to act as a solvent for the oil of the penetrant. Viscosity and activity of the emulsifier are interrelated. A more viscous emulsifier will diffuse into a penetrant at a slower rate. Balancing the activity with the viscosity provides the control necessary to meet a prescribed emulsifier dwell time. The viscosity can range from 10 to 100 centistokes. The higher the viscosity, the more emulsifier is used due to drag-out on the parts during processing. If a lower viscosity emulsifier can be used to produce the desired results, it will be more economical.

Water tolerance is another property of emulsifiers. In practice, the emulsifier tank is normally situated near the wash station. If water is accidentally splashed or sprayed into the emulsifier, the emulsifier takes on a cloudy appearance. A common specification requirement is that emulsifiers must tolerate the addition of up to 5% of water. Some will tolerate up to 15–20% of water. The addition of water will reduce the activity of the emulsifier. However, water reduces the viscosity of the emulsifier and thereby increases its activity.

Hydrophilic emulsifier

Hydrophilic emulsifiers used in penetrant testing are essentially surface-active agents (surfactants) or detergents. The word "hydrophilic" means water-loving or water-soluble. Hydrophilics have an infinite water tolerance. In practice, the emulsifier is supplied as a concentrate and is mixed with tap water to the desired dilution.

2.5. Mechanism of development

The primary purpose of a developer is to form an indication detectable to the unaided eye from penetrant being held in a surface discontinuity. The developer has four basic functions:

- (a) Drawing out a sufficient amount of penetrant from the discontinuity to form an indication;
- (b) Expanding the width of the indication enough to make it visible;
- (c) Increasing the brightness of a fluorescent dye above its bulk brightness; and
- (d) Increasing the film thickness of the indication to exceed the dye's thin film threshold in order to make it detectable.

2.5.1. Granulometry of powders

The developer action appears to be a combination of solvency effect, absorption and adsorption (adsorption implies collection by adhesion to a surface). Absorption refers to assimilation of liquid into the bulk of an absorbent material. The developer powder exerts a combination of adsorptive-absorptive effects on penetrant residues, drawing entrapped penetrants to the test surface. As the penetrant disperses in the developer powder, it forms test indications that can be readily observed by the inspector.

2.5.2. Types and phenomena of fine powder aggregation

In the case of non-aqueous wet and film type developers, solvent action has been shown to play a part in promoting the withdrawal action and enhancing the penetrant indication. As regards their nature, the first powders to be used were simply chalk or talc. Later as the action of developers and their desired characteristics were understood, these developers were found to be

unsatisfactory. Recently much lighter amorphous silica powders are used and they are in many ways superior. Today the best dry powder developers are the combination of powders carefully selected to give all the characteristics in a developer.

Dry powders were the type first to be used with fluorescent penetrants. Today the powders are still very widely used with fluorescent methods, though they have little application with colour contrast penetrants. As regards their nature, the first powders to be used were simply chalk or talc. Later as the action of developers and their desired characteristics were understood, these developers were found to be not satisfactory. Recently much lighter amorphous silica powders are used and they are in many ways superior. Today the best dry powder developers are the combination of powders carefully selected to give all the characteristics in a developer. For safe and effective performance dry powder should be:

- (1) Transparent to ultraviolet and fluorescent radiation.
- (2) White or essentially colourless.
- (3) Uniform in particle size.
- (4) Low in bulk density.
- (5) High in refractive index.
- (6) Chemically inert.
- (7) Non-toxic; free from sulphur and halogen contamination.
- (8) In some cases hydrophobic (water repellent).

2.5.3. Suspension of powders in liquids

Two types of aqueous wet developers are in common use in penetrant inspection. The first consists of insoluble developer particles suspendible in water, while the second contains a developer that is actually soluble in water. Aqueous wet developers usually contain wetting agents and corrosion inhibitors to minimize attack on test objects and penetrant processing equipment. The solvent based developers are generally used in connection with visible dye penetrants.

Aqueous wet developers are normally supplied as dry powders to be suspended or dissolved in water, depending on the type of the wet developer. They differ from dry and other non-aqueous developers in that the developer is applied directly after washing and before drying of the test parts. A typical aqueous suspendible developer is composed of the following constituents:

- (1) Inert insoluble pigment.
- (2) Dispersing agent.
- (3) Wetting agent.
- (4) Corrosion inhibitors.

The developer particles are inert, insoluble, transparent pigments such as metallic oxides, insoluble carbonates, and selected clays. Dispersing agents are required to avoid particle lumping together. The wetting agents act to provide good wetting properties. They also aid in post removal of the dried developer, at the time of post cleaning.

Solvent-suspendible developers are composed of a dispersion of selective developer particles in a volatile solvent system which also acts as a solvent for the penetrant within the defect, thus enhancing the flaw detection capability. The characteristics desired are in general like those of the aqueous wet developers.

Dispersants which are essentially dispersive agents, and surfactants, are employed to ensure uniform developer particle distribution within the developer suspension. These chemicals also serve to reduce the developer particle to make lump by collecting many powder particles within themselves. The solvent suspendible developers, when used properly are the most sensitive developers available today.

2.6. Luminous and ultraviolet spectrum

For viewing the developed penetrant indications of colour dye liquids the inspection area should be luminous and possess a certain intensity. The luminous intensity is described as the amount of light emitted for a second in unit solid angle by a point source in a given direction. The SI unit (System International Units) of luminous intensity is the 'candela'. The term is restricted to a point source. The unit candela is the new international unit replacing the old unit for luminous intensity the candle power. The candela is defined as the luminous intensity, in per-surface of $1/600\,000$ square metre of a black body at a temperature of freezing platinum under a pressure of 101325 N m^{-2} . Black light is essential to the viewing of indications with fluorescent penetrants. Typical value of wavelength of black light radiations employed is 3650 \AA . The visible light which is a form of electromagnetic spectrum constitute the other wave lengths as in the Figure 2.4.

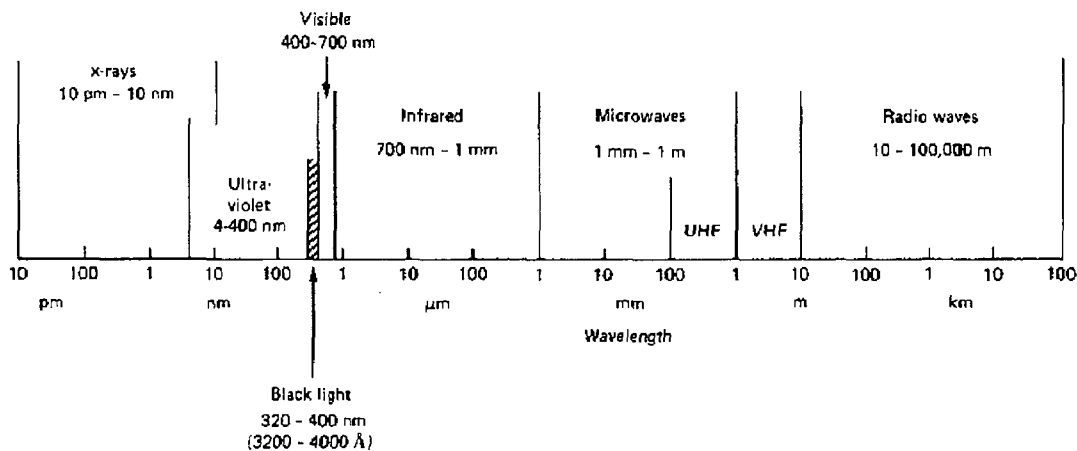

Figure 2.4: Spectrum of light through the visible, "black light" and ultraviolet wave lengths.

2.6.1. Colour and fluorescence

Fluorescence phenomena is a form of luminescence in which certain substances (e.g. cadmium sulphate, barium platinocyanid, paraffin oil, fluorescent solutions) are capable of absorbing light of one wavelength (i.e. colour, when in the visible region of the spectrum) and in its place emitting light of another wavelength or colour. Unlike phosphorescence, the phenomena ceases immediately after the source of light is cut off. Dyes commonly in use in fluorescent penetrants give off light when irradiated by black light in the yellow-green or green-blue portion of the visible spectrum

2.6.2. Colours

Colour is the visual sensation resulting from the impact of light of a particular wavelength on the cones of the retina of eye. Light has three characteristics hue, which is determined by its wavelength, saturation, the extent to which a colour departs from white and luminosity, a measure

of its brightness (for a light or other emitting source). If the source is a pigment, dye etc. that reflects rather than emits light this characteristic is called lightness.

2.6.3. Absorption of light

The observation of indications arising due to discontinuities for fluorescent penetrants is due to absorption of light. The phenomenon of fluorescence occurs when fluorescent penetrants absorb light of typical wavelength and emit light of other wave length of visible colour. Use of black light is made to observe such indications which glow as greenish yellow.

2.6.4. Beer's law

If two solutions of the same coloured compounds are made in the same solvent one of which, say, is twice the concentration of other, the absorption of light due to a given thickness of the first solution should be equal to that of twice the thickness of the second. Mathematically, this may be expressed:

$$I_1 c_1 = I_2 c_2 \quad (5)$$

When the intensity of light passing through the two solutions is constant and if the intensity and wave length of light incident upon each solution is the same.

2.6.5. Fluorescent pigments

Fluorescent dyes are selected for high fluorescence and permanence under ultraviolet light. Fluorescent pigments used as tracer in liquid carrier of the penetrant make it more sensitive than to visible dye penetrant for minute indications such as cracks or pinholes. The indications appearing because of surface open discontinuities fluorescence under black light.

2.7. Basic formulation of penetrating liquids with oily and non oily base

2.7.1. Additives and conditioners

The penetrants for use in the water-washable process are not simple dye solutions but rather complicated formulations of a number of ingredients. These include penetrating oils, dyes, emulsifying agents and stabilizing agents. The constituents are added or incorporated into such proportions so as to give a penetrant with high penetrativeness, dye solubility, ease of washing and stability of dye i.e. it does not separate itself under wide variations in temperatures and other operating conditions.

In visible dye penetrants, there is a dye, usually red, used as tracer in the carrier or vehicle fluid. In the case of fluorescent penetrants, there is added a brilliant fluorescent dye into the carrier fluid. The carrier fluid can be oily base or non oily. Water washable penetrants contain an emulsifier so that they are self emulsifiable or water washable. In addition they also contain dispersive agents and corrosion inhibitors. The function of dispersive agents is to help in distributing the dye evenly and completely over the surface to be inspected and carry it to any surface open defects. This ability is in addition to the characteristic of retaining the dye in solution or suspension. In case of post emulsifiable and solvent removable penetrants, there is no emulsifier incorporated into them. These are designed to be insoluble in water and cannot be removed with water rinsing alone. They are designed to be selectively removed from the surface of a part by the use of a separate emulsifier, which makes the excess surface penetrant water washable after a given proper emulsification time. In case of solvent removable penetrants, the excess surface penetrant is removed by the use of a lint free cloth moistened with solvent.

2.8. Removers used in the process

2.8.1. Basic formulation and properties

The removers are required in the following three stages of the penetrant processes:

- (a) Pre-cleaning.
- (b) Removal of excess penetrant.
- (c) Post cleaning (following penetrant inspection).

Removal of light oil or grease on the surface of the test piece is usually carried out by treatments such as degreasing, emulsion cleaning, solvent wiping or alkaline cleaners. The removers used in dye penetrant processes are organic solvents, which include, aliphatic petroleum or chlorinated hydrocarbons (similar to those used in vapour degreasing), or blends of two or more solvents. Aliphatic petroleum include such familiar fluids as kerosene, naphtha, mineral spirits and stoddard solvent. Other solvents include alcohols, ketones, benzol, toluol, 1, 1, 1, – trichloroethane, glycol and other as well as unsaturated chlorinated hydrocarbons such as trichloroethylene.

2.8.2. Emulsifiers

The use of emulsifiers is made in case of post-emulsifiable penetrant process to make the excess surface penetrant water-washable. The proper control of emulsification time is critical as can minimize the chances of over-washing and thereby increasing the sensitivity and reliability for the detection of shallow discontinuities. The test conditions which influence the selection of emulsification time are as under:

- (a) Penetrant and emulsifier being used.
- (b) Type of surface condition.
- (c) Performance desired.
- (d) Type of rinse used.

2.8.3. Lipophilic and hydrophilic agents

The lipophilic or oil base emulsifiers were the early type of emulsifiers to be used in the post emulsification of the penetrant. These emulsifiers being oil base dissolve readily and diffuse into oily penetrant at a some what uniform rate. They are used as supplied by the manufacturers. Figure 2.5 shows the basic action of the lipophilic emulsifiers during the removal of surface penetrant.

A red dye is incorporated in the emulsifier fluorescing pink under black light so that when washing a part under black light it is easy to follow the progress of removal of both emulsifier and penetrant. The most recent development is that of water-based or hydrophilic emulsifier. It is usually made of non-ionic surfactant concentrates. This type of emulsifier is dry powder or concentrated liquid, and must be dissolved or diluted in water before use. The desirable concentration depends upon the method by which the emulsifier must be applied to the test parts. Hydrophilic emulsifiers when applied by spraying, function by their detergent and scrubbing action.

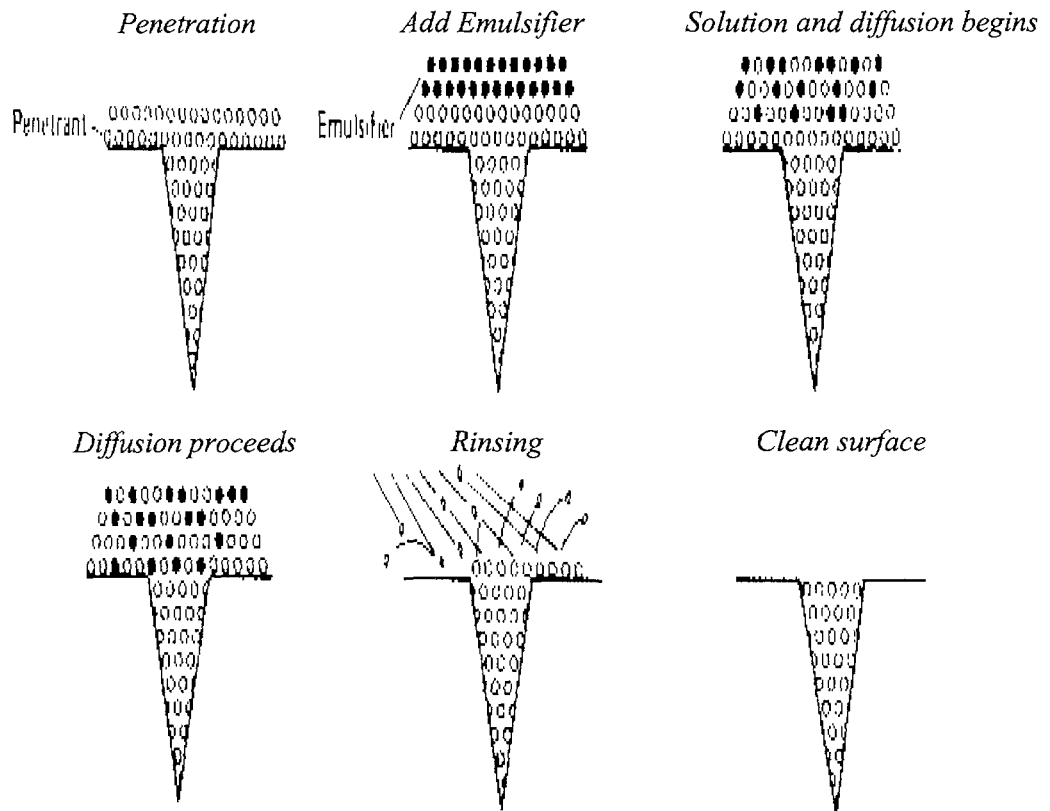

Figure 2.5: Mechanism of action of lipophilic emulsifier.

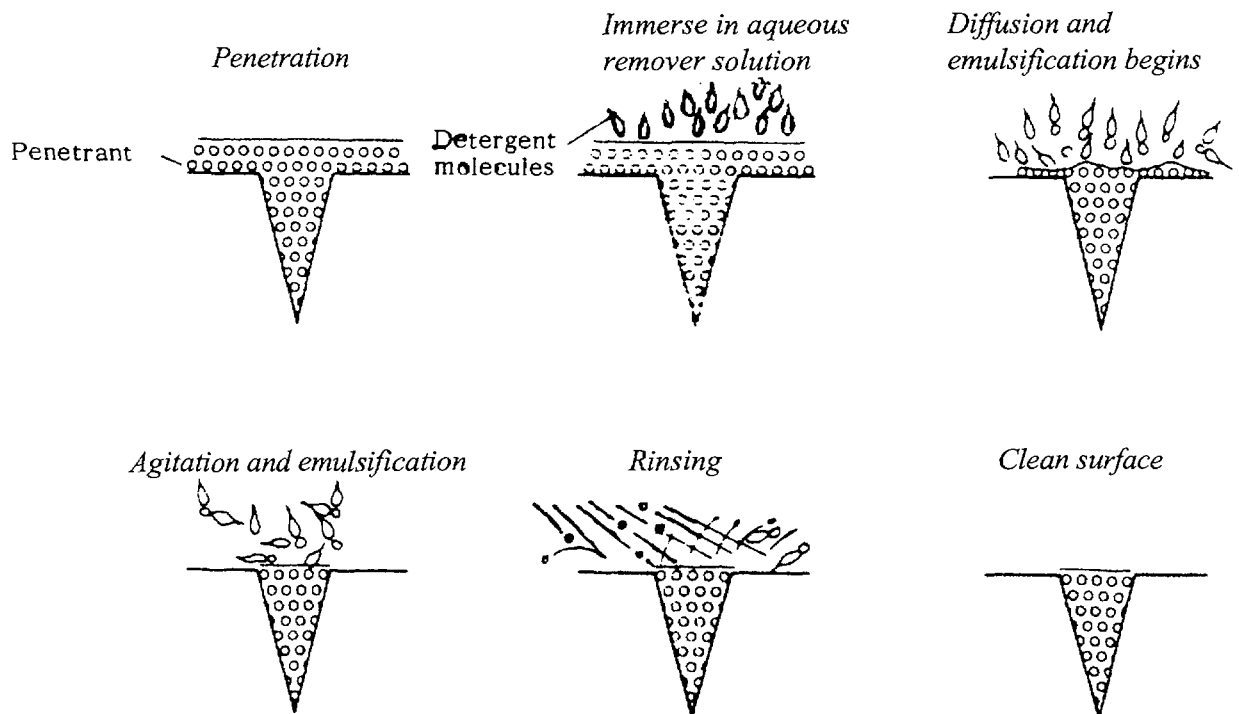

Figure 2.6: Mechanism of action of hydrophilic emulsifier.

3. PROCESSING (PT)

3.1. Reparation of the work-pieces, treatment, identification and protection of the areas not to be examined

3.1.1. Treatment

The success of any penetrant inspection procedure is greatly dependent upon the surface and the discontinuity being free of any contaminant that might interfere with the penetrant process. The contaminants can result in failure of penetrant to (a) wet the test object surface, (b) enter into discontinuities, and (c) bleed out of discontinuities. All parts or areas of parts to be inspected must be clean and dry before the penetrant is applied. By the word 'clean' we mean that the area under test be free of any rust, scale, welding flux, spatter, grease, paint, oily films, dirt, etc. The treatment processes involved for removing such contamination should be carefully chosen and adopted. Residues from cleaning processes can adversely react with the penetrant and reduce its sensitivity and performance greatly. Acids and chromate's, in particular, greatly reduce the sensitivity of fluorescent penetrants.

3.1.2. Identification

The materials to be inspected by dye penetrant inspection method can be identified and classified as to be metallic (ferrous and/or non-ferrous), non-metallic such as plastics, ceramics and glass. Among metallic materials they can be further recognized or categorized to be as-forged, as-rolled, as-welded and as-cast.

The materials to be inspected are further identified keeping in view their initial procedural requirements such as:

- (a) The material shapes or sizes to be examined, and extent of examination.
- (b) Type (number or letter designation if available) of each penetrant, remover, emulsifier and developer.
- (c) Processing details for pre-examination cleaning and drying, including the cleaning materials used and minimum time allowed.
- (d) Processing details for applying penetrant; the length of time that the penetrant will remain on the surface and temperature of surface and penetrant.
- (e) Processing details for removing excess penetrant and for drying the surface before applying the developer.
- (f) Processing details for applying the developer and length of development time before interpretation.
- (g) Processing details for post-examination cleaning.

The areas not to be examined should be protected from the penetrant processing materials.

3.2. Cleaning prior to inspection

3.2.1. Various techniques applicable

Solvents

There are a variety of solvent cleaners that can be effectively utilized to dissolve such soils as grease, oily films, waxes and sealants, paints and in general organic matter. These solvents should be residue free, especially when used as a hand wipe solvent or as a dip tank degreasing solvent. Solvent cleaners are not recommended for removal of rust, scale, welding flux, spatter and in general inorganic soils. In solvent cleaning, test objects are immersed and soaked in tanks of common organic liquid solvents. Organic solvents are normally used at or near room temperature. Oil, grease and loose metal chips are removed from metal surfaces, with or without agitation. After solvent cleaning the parts are dried at room temperature or by external heat. Since contamination removed from test parts is retained in the solvent, both cleaning efficiency and the final cleanliness of the test objects can decrease with continual use. Nearly all metals and alloys can be cleaned in common solvents unless acid or alkaline contamination is introduced into the solvents. Solvent cleaning is often used in combination with separate acid or alkaline cleaning procedures for removal of complex soils. Common organic solvents include aliphatic petroleum or chlorinated hydrocarbon or blends of two or more solvents. Aliphatic petroleum's include such familiar fluids such as kerosene, naphtha, mineral spirits and stoddard solvent. Other solvents include alcohol's (ethanol, methanol or isopropanol), ketones benzol, toluol, 1, 1, 1,-trichloroethene, glycol ethers as well as unsaturated chlorinated hydrocarbon such as trichloroethylene.

Vapour degreasing

Vapour degreasing is a preferred method of removing oil or grease type soils from the surface of the parts and from open discontinuities. It will not remove inorganic-type soils (dirt, corrosion, salts etc.) and may not remove resinous soils (plastic-coatings, varnish, paint, etc.). Because of the short contact time, degreasing may not completely clean out, deep discontinuities and a subsequent solvent soak is recommended.

Since vapour degreasing usually employs a chlorinated solvent, the aerospace and nuclear industries have become concerned about the effects of vapour degreasing on titanium, austenitic, stainless steels and other chloride-sensitive alloys. Some specifications forbid use of vapour degreasing method of cleaning for such materials.

The hot vapours of a chlorinated solvent such as 1, 1, 1-trichloroethane (which is less toxic than tri-chloroethylene or perchloroethylene) are used to remove oils, greases, or waxes from metallic test objects in preparation for penetrant inspection. An open steel tank contains the heated liquid solvent which boils and generates the solvent vapour. This vapour condenses upon the relatively cool metal surfaces of parts placed in the vapour zone above the heated tank. Some vapour degreaser units provide means also for immersing the test objects in the warm or boiling solvent or for spraying clean solvent upon the parts.

The preferred solvent is 1, 1, 1-trichloroethane (methyl chloroform) which boils at 72.2°C (167°F). During vapour degreasing, the contaminated solvent condensate drips back into the heated tank, carrying contaminants into the bath. During evaporation, only clean solvent vapours are produced, so that test parts are given adequate final rinsing in clean vapour. The test objects come out of the vapour degreasing operation both clean and dry, but warm. After adequate cooling, they are ready for application of the liquid penetrant if no other forms of contamination exist.

Detergent solutions

Detergent cleaning may be used to clean almost any specimen. They can be alkaline, neutral, or acidic in nature, but must be non-corrosive to the item being inspected. The cleaning properties of the detergent solutions facilitate complete removal of soils and contamination from the surface and void areas, thus preparing them to absorb the penetrant. Cleaning time should be on an average 10 to 15 minutes at 170 to 200°F (77 to 93°C) with moderate agitation, using concentrations (normally 6 to 8 oz/gal. or 45 to 60 kg/m³) as recommended by the manufacturer of the compound.

Solutions having a chemical action (acid and alkali removers, etc.)

Alkaline cleaners are non-flammable water solutions containing specially selected detergents for wetting, penetrating, emulsifying and saponifying various types of soils. Hot alkaline solutions are used for rust removal and descaling to remove oxide scale which can mask surface discontinuities. Parts cleaned by alkaline cleaning process must be completely free of cleaner and thoroughly dried by heat prior to the penetrant inspection process. Inhibited acid solutions (pickling solutions) are routinely used for descaling part surfaces. Acid solutions etchants are also used routinely to remove the smeared metal that peens over surface discontinuities. Etched parts and materials must be rinsed completely free of etchants, the surface neutralized and thoroughly dried by heat prior to the application of penetrants. While making use of alkaline cleaners, paint removers (solvent type) and acids, the parts must be rinsed thoroughly and dried before application of penetrants. Some cleaning solvents are flammable and can be toxic too, observe all safety precautions in their use.

Ultrasonic cleaning

Ultrasonic cleaning method adds ultrasonic agitation to solvent or detergent cleaning to improve cleaning efficiency and decrease cleaning time. It should be used with water and detergent if the soil to be removed is inorganic (rust, dirt, salts, corrosion products etc.) and with organic solvents if the soil to be removed is organic (grease and oily films etc.). After ultrasonic cleaning the parts should be heated to remove the cleaning fluid, then cooled to at least 125°F (52°C).

Mechanical means (grinding, sand blasting, brushing, etc.)

Metal loose scale removing processes such as filing, grinding, brushing, sand blasting etc. are often used to remove such soils as carbon, rust, scale and foundry adhering sands, as well as to deburr or produce a desired cosmetic effect on the part. These processes may decrease the effectiveness of the penetrant examination by smearing or peening over metal surfaces and filling discontinuities open to the surface, especially for soft metals such as aluminium, titanium, magnesium and beryllium alloy. Generally, abrasive methods are used on surfaces that are file hard. However, such techniques must minimize plastic metal flow to avoid covering defects at the surfaces. If it is suspected that discontinuity openings may have been closed, some method such as etching should be used to reopen the imperfection prior to testing.

3.2.2. Conditions and limitations of the different cleaning techniques

The conditions or the choice of a suitable cleaning method is based on such factors as:

- (a) Type of contaminant to be removed since no one method removes all contaminants equally well.

- (b) Effect of cleaning method on the parts.
- (c) Practicality of the cleaning method for the part (for example, a large part cannot be put into a small degreaser or ultrasonic cleaner).
- (d) Specific cleaning requirements of the purchaser.

The cleaning processes have to be carefully chosen, as no harm to the sample can be tolerated. Detergents can be alkaline or acidic in nature and as such should be employed for metals which do not show a strong reaction to acids and alkalis. Similarly abrasive blasting may be used only to the extent that the surface does not become peened to a degree that could seal a defect or contaminate the opening with abrasive residue. Use of steel wire brushes either flat or rotary are not used on non-ferrous metals. Vapour degreasing is the preferred method of final precleaning. An exception to vapour degreasing is titanium where chlorinated solvents are prohibited. The final pre-cleaning of titanium parts is with stoddard or dry-cleaning type solvent followed by oven drying at 52°C (125°F).

3.2.3. Comparison of the effectiveness of the different techniques in relation to the surface state of the specimen

The cleaning effectiveness of respective methods for precleaning of the surface for liquid penetrant testing has been summarized in a tabular form as given in Table 3.1.

3.3. Conditions and requirements for the different drying stages

Drying of the parts before any penetrants process is necessary for the following reasons:

- Water traces present within leaks or discontinuities will minimize or prevent the penetrants' entry into leaks or surface defects.
- The parts are also to be dried for the applicability of a particular process, for example, the part is dried after the removal of excess penetrant and prior to the application of dry or non-aqueous wet developer. When water-based wet developer is used, the specimen is dried after the developer has been applied.

3.3.1. Use of cold and hot air

Parts can be dried by using a hot air recirculating oven, a hot air blast, or by exposing to ambient temperature. Drying is best done in a thermostatically controlled recirculating hot air dryer.

3.3.2. Temperature and time

The temperature in the dryer is normally maintained between 150°F and 225°F (66°C and 107°C) for most applications. Parts' temperature should not exceed 125°F (52°C). The time for drying of parts in the drying oven should not be excessive enough to destroy the sample. Drying time is determined by the size and composition of the specimen, and visual observation usually fixes the length of the drying cycle. Excessive heat or too long a drying time tends to bake the penetrant out of discontinuities.

TABLE 3.1: COMPARISON OF THE EFFECTIVENESS OF DIFFERENT TECHNIQUES IN RELATION TO THE SURFACE STATE OF THE SPECIMEN

Sr. no.	Type of contaminants	Respective methods in order of their preference	Remarks
1.	Soluble contaminants such as mineral oils.	Vapour degreasing. Hot tank alkaline cleaning. Steam cleaning. Solvent emulsion cleaning. Water emulsion cleaning. Solvent washing.	Since vapour degreasing process usually employs chlorinated solvents, their effects on metals like titanium, austenitic stainless steels and other chlorine sensitive alloys are of concern in aerospace and nuclear industry. Hot alkaline cleaning can be corrosive to metals such as aluminium alloys and sensitized austenitic steels.
2.	Scale, Rust, Corrosion products and Oxides.	Alkaline or acid type removal procedures. Wire brushing vapour or sand blasting. Electrocleaning.	It is necessary to rinse the parts thoroughly after the use of acid or alkaline cleaning procedures. Acids or alkaline residues can act to reduce penetrant dye fluorescence and reduce the penetrant indications. High speed rotary brushes should be avoided since they can smear surface of the metal over defects.
3.	Carbon varnish, or other tightly held soil.	Solvent type carbon remover. Alkaline type carbon remover. Wire brushing. Vapour or sand blasting.	Mechanical processes that peen or smear surface material may act to close openings into discontinuities so that penetrant indications cannot be formed. Such abrasive methods often require a subsequent acid etching treatment to reopen the discontinuities.
4.	Paint coatings	Solvent type paint removers. Alkaline type paint removers. Wire brushing. Vapour or sand blasting.	Factors which influence paint removal include: Surface preparation prior to painting. Type of paint. Number of coats of paint. Age or cure of paint finish. Type of paint remover used. Nature of the substrate.
5.	Surface roughness.	Abrasive polishing. Electro-polishing. Strong acids or alkalis.	Surface roughness reduces ease of rinsing and increases difficulty of hand wiping. Rinse with fresh water. Use neutralizing rinse, fresh water rinse and dry.

3.4. Inspection process

3.4.1. Application of penetrating agent

Application techniques

It does not matter how penetrant is applied to surfaces, provided that it covers the entire surface to be inspected. Methods which can be used include immersion, flow-on, electrostatic spray, aerosol spray, conventional spray, brush-on, wipe-on or application as a fog. Small parts are quite often placed in a suitable basket and dipped into a tank of penetrant. On larger parts and with complex geometries, penetrant can be applied effectively by brushing or spraying. Both conventional and electrostatic spray guns are effective means of applying liquid penetrant to the test part. Figure 3.1 (a), (b).

Temperature

The temperature of the test part surface should be between 16°C to 52°C.

When it is not practically possible to make a liquid penetrant examination within the temperature range 16 to 52°C (60 to 125°F), the examination procedure at the proposed temperature requires further qualification. This shall be accomplished by producing quench cracks in an aluminium block.

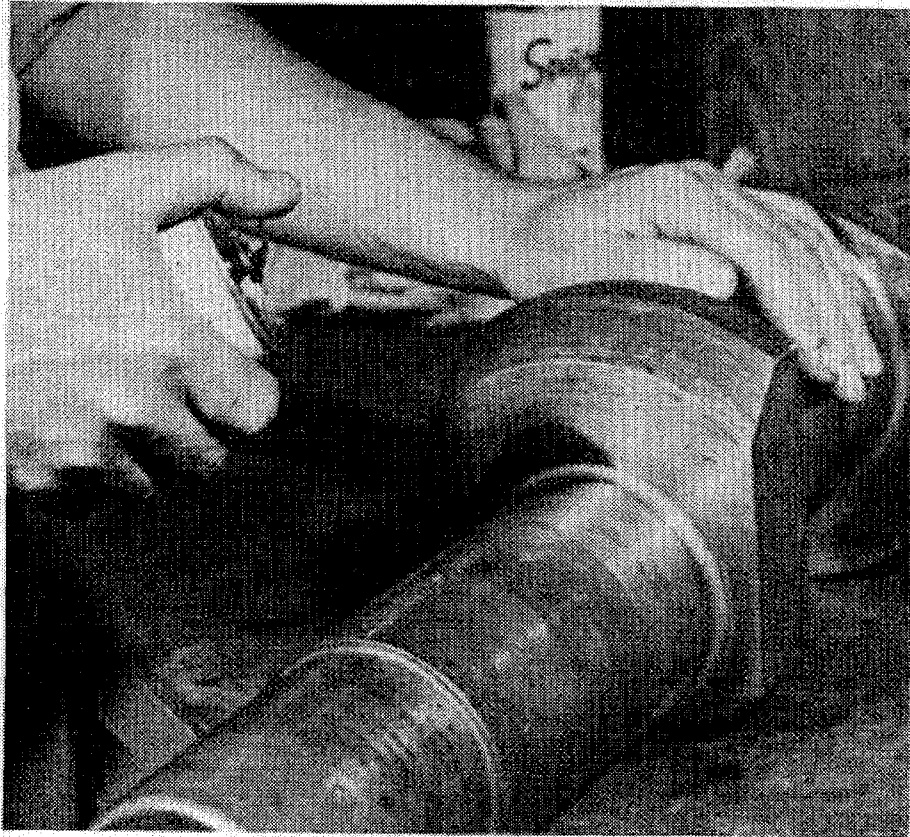

(a)

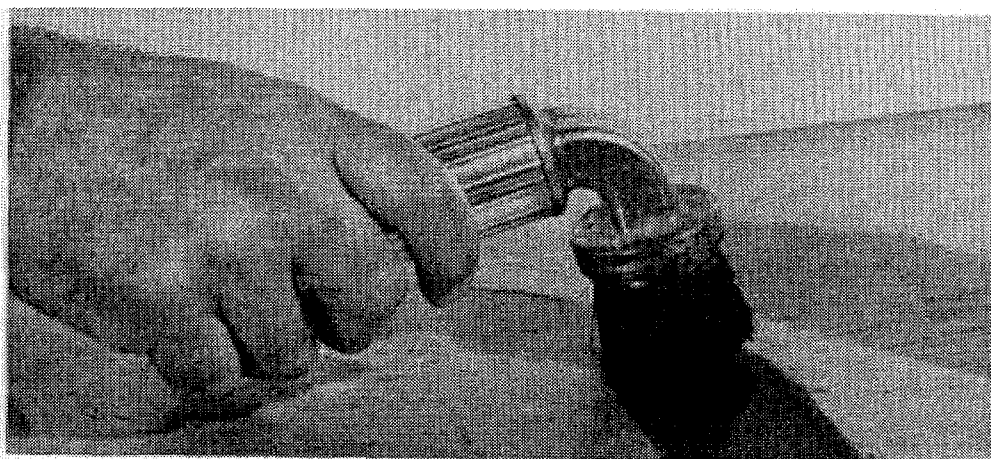

(b)

Figure 3.1: Penetrant application (a) by spray can, and (b) by brushing.

Penetration time

A broad guide to correct time is contained in Table 3.2. The specimen size, composition, nature of discontinuities sought and the temperature of the test area, all affect penetration time which is also called dwell time or residence time.

TABLE 3.2: TYPICAL MINIMUM PENETRATION TIMES

Material	Form	Type of discontinuity	Water-washable penetration time*	Post-emulsified penetration time*	Solvent removed penetration time*
Aluminium	Castings	Porosity	5 to 15 Min	5 Min**	3 Min
		Cold shuts	5 to 15	5 **	3
	Extrusions and Forgings	Laps	NR***	10	7
		Lack of fusion	30	5	3
	Welds	Porosity	30	5	3
		Cracks	30	10	5
Magnesium	All	Fatigue cracks	NR***	30	5
		Porosity	15	5**	3
	Castings	Cold shuts	15	5**	3
		Laps	NR***	10	7
	Extrusions and Forgings	Lack of fusion	30	10	5
		Porosity	30	10	5
Steel	Welds	Cracks	30	10	5
		Fatigue cracks	NR***	30	7
	All	Porosity	30	10**	5
		Cold shuts	30	10**	7
	Castings	Laps	NR***	10	7
		Lack of fusion	60	20	7
Brass and Bronze	Welds	Porosity	60	20	7
		Cracks	30	20	7
	All	Fatigue cracks	NR***	30	10
		Porosity	10	5**	3
	Castings	Cold shuts	10	5**	3
		Laps	NR***	10	7
Plastics	Extrusions and Forgings	Lack of fusion	15	10	3
		Porosity	15	10	3
	All	Cracks	30	10	3
Glass	All	Cracks	5 to 30	5	5
		Lack of fusion	30	5	3
Carbide-tipped Tools	All	Porosity	30	5	3
		Cracks	30	20	5
Titanium and High Temp. Alloys	All		NR***	20 to 30	15
All Metals	All	Stress or inter-granular corrosion	NR***	240	240

* For parts having a temperature of 60° to 125°F (16° to 52°C)

** Precision castings only

*** NR – Not Recommended.

3.4.2. *Removal of excess penetrating agent*

Various methods of removal depending on type of penetrant

(a) Water-dispersable

Due to ease of post-cleaning, water-base penetrants, both visible and fluorescent, that use water as the thinner instead of a hydrocarbon have been accepted for LOX (liquid oxygen) related apparatus inspection. Water-base penetrants, if their water content is sufficiently high, are found to be LOX insensitive when subjected to the impact test.

The success with water base penetrants under LOX usage condition is attributed to the ease of removal of residues, both surface and flaw entrapped. This residue will be primarily a water soluble surface active agent, a detergent in itself, which facilitates post cleaning (the most critical step in the process when LOX usage is involved). Post cleaning is simplified if the water-base penetrant is of the self-developing fluorescent types. Since there is no "remover" (other than water) and no developer, the post-cleaning operation involves only penetrant residue. Usually the residue of the water-soluble penetrant dissolves more readily when the water-base cleaner includes an additive such as a volatile glycol ether or light alcohol to lower the residue's viscosity. In addition to being water soluble, the residue of the water-base penetrant, once its water content has evaporated, also readily dissolves in chlorinated solvent cleaners such as perchloethylene.

(b) Water-soluble penetrants

For water washable penetrants, the excess penetrants can be removed directly from the part with water washing by using manual, semi-automatic, automatic wide fan shaped water spray or immersion equipment. Water pressure should be kept constant and not exceed 50 psi (345 kPa). Generally a coarse spray is recommended. The temperature of water for effective cleaning should be within a minimum of 60°F to 90°F (16°C to 32°C). The duration of the rinsing cycle should not be excessive enough to cause over-washing. For fluorescent penetrant, the rinsing operation should be monitored under black light.

Care must be exercised in rinsing to avoid over-washing or the removal of the penetrant from the discontinuities. Excess spraying time or excess spray pressure, as well as complete immersion of parts in rinse water, may cause removal of penetrant from discontinuities and should be avoided. This is in particular for wide and shallow defects where the chances of removal of penetrant out of such defects are more Figure 3.2.

(c) Solvent soluble penetrants

The volatile organic solvents used for penetrant removal are the most aggressive reagents used for this purpose, consequently great care must be taken in their use. When solvent removers are used in manual systems, they must only be applied by the wipe method. The excess penetrant is to be cleaned off, by using wipes of clean lint free material, repeating the operation until most traces of penetrant have been removed. Then lightly moisten with solvent a lint-free cloth and wipe the surface until all remaining traces of excess penetrant have been removed. On rough surfaces it may be necessary to apply cleaner to the rag or towelling prior to wiping part surfaces. Flushing the surface with solvent following the application of penetrant and prior to developing is prohibited Figure 3.3.

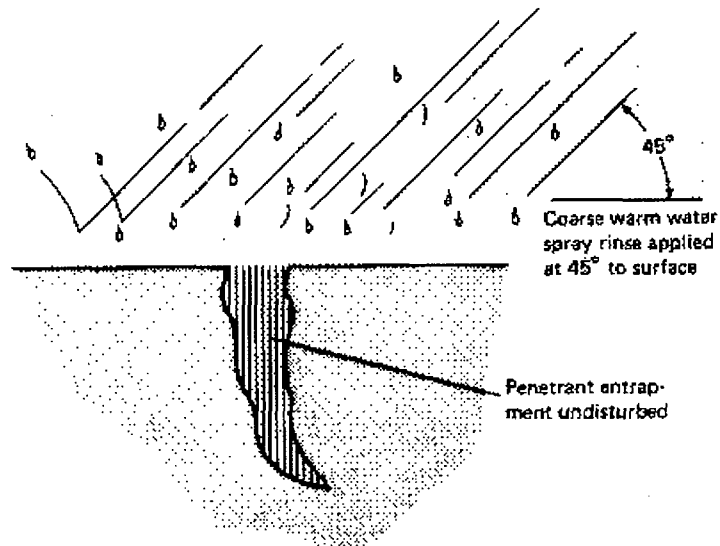

Figure 3.2: Angled coarse warm water spray for removal of excess water-washable penetrant.

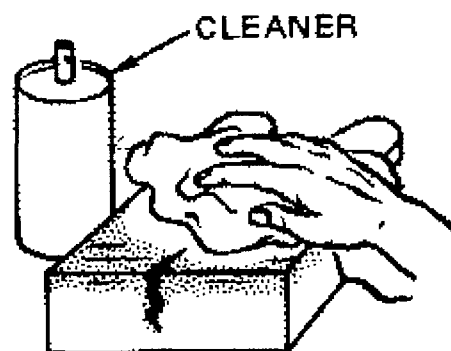
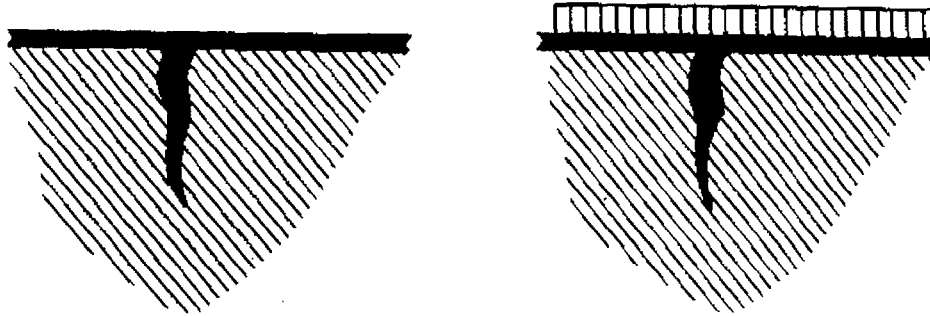

Figure 3.3: Cleaning of excess penetrant by solvent damped cloth.

(d) Post-emulsifiable penetrants

Post emulsifiable penetrants are not directly water-washable and they require the use of an emulsifier (oil or water base). After the required penetration time the excess penetrant on the part is emulsified by dipping, flooding, or spraying the parts with the required emulsifier. Application of emulsifier with brush is not acceptable. Effective rinsing of the emulsified penetrant can be accomplished in the maximum as for directly water-washable penetrant. The length of the time that the emulsifier is allowed to remain on the part and in contact with penetrant called the emulsification time is dependent on the type of emulsifier (fast acting, slow acting, oil base or water) and the surface condition of the part. In general the emulsification time is from few seconds to several minutes depending on the activity of the emulsifier, surface of the part and the type of discontinuities sought. The average emulsification time should be about 30 seconds. Figure 3.4 (a)–(f) explains various steps for a post-emulsifiable process.



(a) Penetrant seeps into discontinuity. (b) Emulsifier is applied to penetrant.

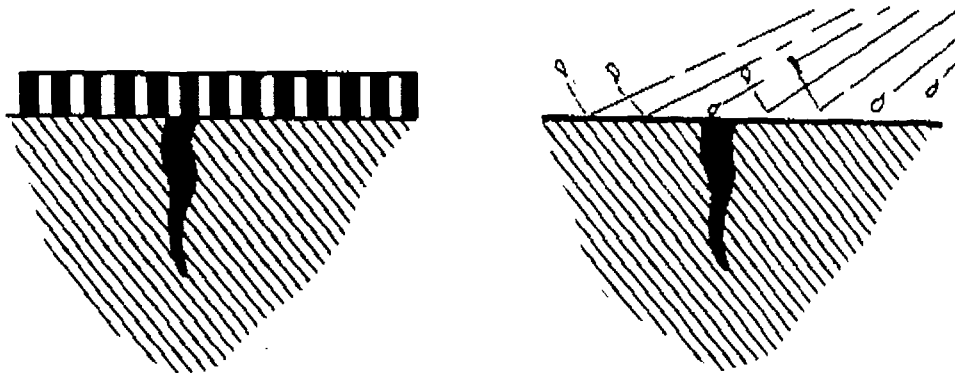

(c) Surface penetrant is emulsified. (d) Water spray removes emulsified penetrant.

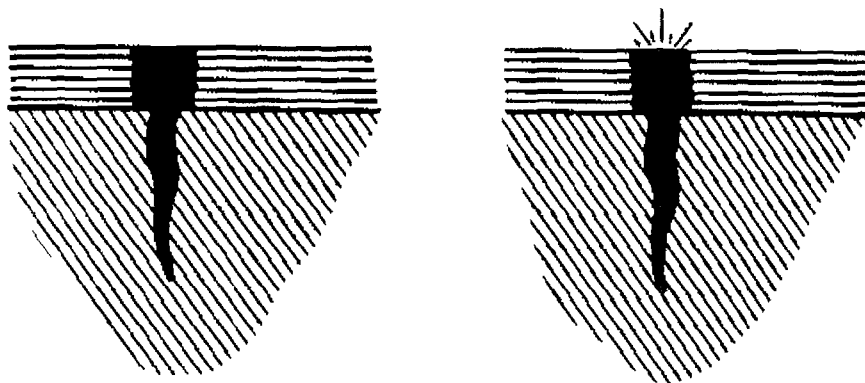

(e) Developer draws penetrant from discontinuity. (f) Depending on type penetrant, indication is viewed under visible light or black light.

Figure 3.4: Post-emulsification process.

3.4.3. Conditions for the application of lipophilic and hydrophilic emulsifiers

Application of lipophilic emulsifier

The most common method of application of lipophilic emulsifying agent is by immersion followed by drainage. Spray application followed by drainage has also been used successfully. Brush application of lipophilic emulsifier is forbidden, since this will cause loss of penetrant from discontinuity sites. Flowing on of a lipophilic emulsifier is not recommended since the contact time for this process is very critical and it is not possible to cover any but small components rapidly enough to ensure uniform processing. It is essential that complex-shaped components are rotated during the drainage stage so that the various surfaces receive similar processing.

Specific contact times for lipophilic emulsifier should be established for each application and are extremely important. Those values can vary between 60 and 180 seconds depending on the actual emulsifying agent, the penetrant in use and the surface state of the components. Lipophilic emulsifiers are used undiluted at temperatures between 15°C and 25°C.

Application of hydrophilic emulsifier

Application of such emulsifier is by immersion in an aqueous solution. The normal concentration is within the range 2.5 to 20% v/v. Specifications vary as to whether agitation is forbidden, allowed or required. If agitation is used, it should be mechanical rather than by use of compressed air, since compressed air can cause heavy foaming and may not be clean and may introduce contaminants. Maximum contact times are given in specification as being approximately 2–4 minutes, depending on application.

Hydrophilic emulsifier (detergent) solutions can also be applied by spray or as foam. The concentration of the solutions tends to be much lower (up to 2.5% v/v maximum) when these methods of application are used. Once conditions have been established, they should be strictly observed in practice.

Drying

The drying requirements are the same as discussed in Section 3.3.

Requirements and precautions in the removal stage

- (a) Care should be exercised to minimize the chances of over-washing and over emulsification.
- (b) When using solvent cleaner, flushing with solvent is prohibited.
- (c) Cloth used for cleaning should be lint free.
- (d) The coarse water spray is recommended. The water spray pressure should be kept constant and not be more than 50 PSI. The temperature of water for effective cleaning should be within a minimum of 60 to 90°F (16 to 32°C).

3.4.4. Application of the developer

General

Some penetrants provide sufficient discontinuity indications without a developer. They are self-developing. But generally, when maximum sensitivity is desired, a developer is required. The developer assists in the detection of penetrant retained in discontinuities by aiding in the capillary

bleed-out process (the developer acts as a blotting agent), and by accentuating the presence of penetrant in a discontinuity. Developer accentuates the presence of a discontinuity because it causes the penetrant from the discontinuity to spread out over a greater area. It also serves as a colour contrast background for the visible dye used in the visible dye processes and for the fluorescent material used in the fluorescent processes. Developer is available in both dry and liquid forms and the selection of developer is in accordance with the manufacturer's recommendation for the type of penetrant used. When a dry or non-aqueous wet developer is used, the specimen must be completely dry before the developer is applied. When a water-based wet developer is used, it is applied immediately after penetrant removal is accomplished and prior to the drying operation.

Dry developer

Dry developer, being a loose, fluffy talcose powder with high absorbent properties, is applied to a specimen by dusting, blowing, or dipping the specimen. The application is usually accomplished in a booth with a blower or fan arrangement that removes loose powder from the atmosphere. No preparation of the powder is necessary and the only requirement is that it be evenly distributed over the test surface, which must be completely dry Figure 3.5.

Nonaqueous wet developer

Non-aqueous wet developer is a suspension of absorptive white powder in a solvent vehicle. It is usually applied by spraying from a pressurized spray can or other spraying device such as a paint spray gun Figure 3.6. When used in bulk form, care must be exercised to keep the powder thoroughly mixed in the specimen without soaking the test surface. When properly mixed and applied, non-aqueous wet developer is the most sensitive of all the developers in detecting fine discontinuities.

Water-based wet developer

Water-based wet developer may be either a suspension of absorptive white powder in water, or a water-soluble absorptive white powder mixed with water. The suspension type requires mild agitation prior to and during use to keep the powder particles in suspension; the water-soluble developer does not. The water-soluble powder, once mixed with the water, remains in solution. After excess penetrant is removed from the specimen, and while it is still wet, wet developer is applied by either dip (immersion), flow-on, or spray techniques. These fast and effective methods of application, combined with the time saved by applying developer to the wet specimen, make water-based wet developer well suited for use in rapid, production line testing. Wet developer is applied so as to form a smooth, even coating, and particular care is taken to avoid concentrations of developer in dished or hollowed areas of the specimen. Such concentrations of developer mask penetrant indications and are to be avoided.

Previous treatment of the developer

The developers to be used are maintained and stored with care to keep their performance satisfactory. Dry developers require little care however they should be watched not to be badly contaminated with foreign matter. If insufficiently dried parts are continually placed in dry developer, lumps or balls of dry developer can form which will eventually ruin the effectiveness of developer. Slight contamination can also occur when lumps of penetrant soaked developer fall from heavy indications or poorly washed parts. When fluorescent penetrants are being used, developers should also be checked with black light periodically to ensure that developer tanks have not become contaminated with fluorescent material.

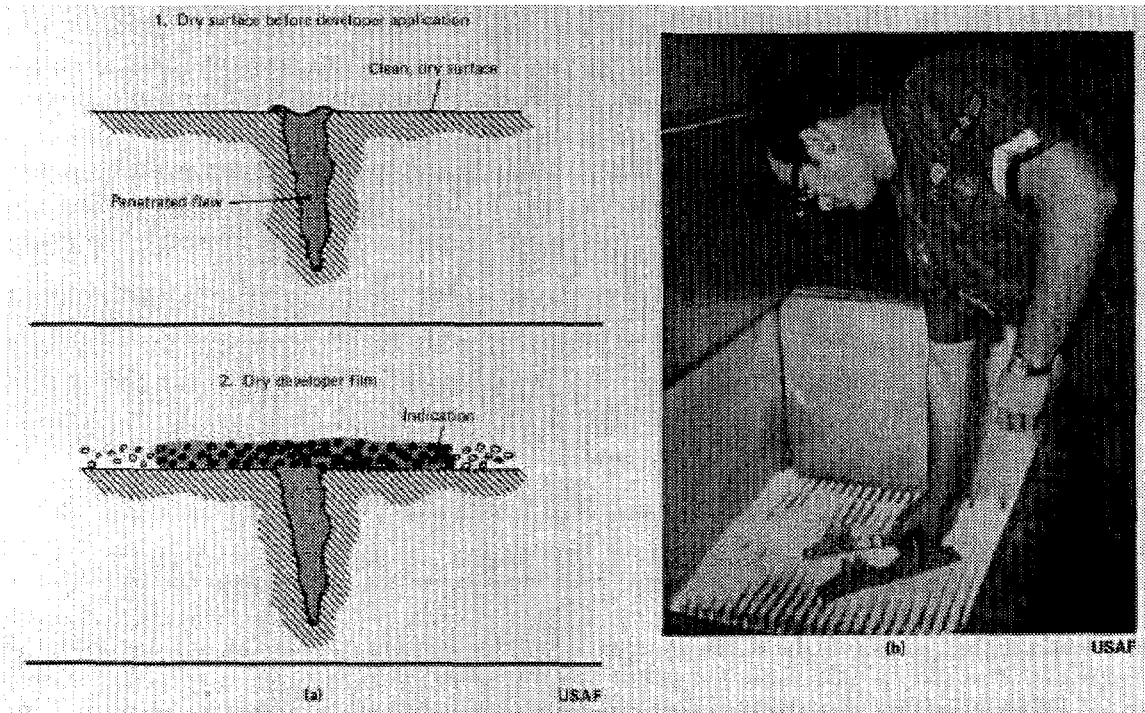

Figure 3.5: Application of dry developer by dipping method.

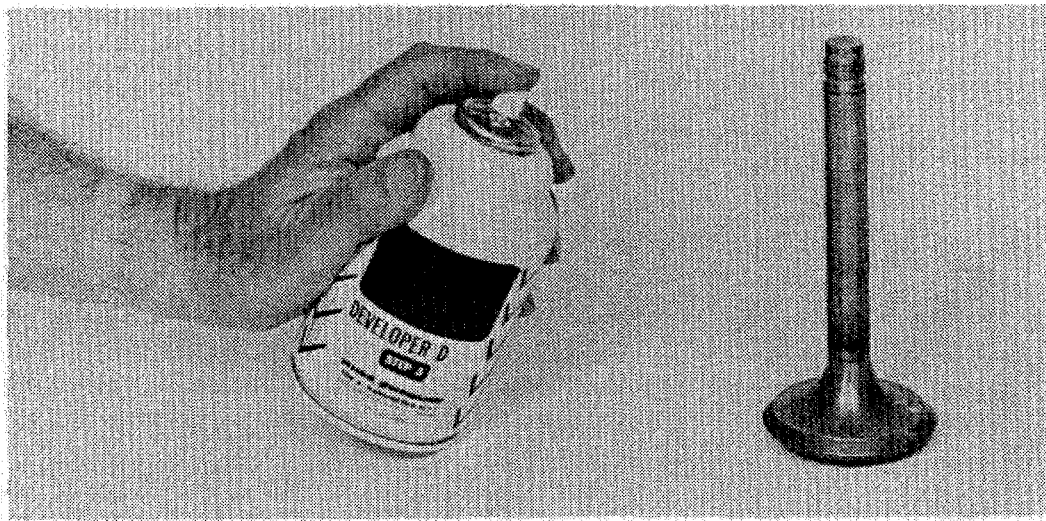

Figure 3.6: Application of developer by spraying method.

The other type of developers, for example, aqueous wet developers are prepared by mixing dry developer, powders or liquid concentrates with water in the proportions recommended by the manufacturer. The proper consistency of aqueous wet developer suspensions must be maintained by replacing water lost through evaporation or powder lost through dragout. The solvent suspendible developers exist in two types namely:

- (i) Non-aqueous plastic (lacquer) developers.
- (ii) Non-aqueous solvent suspendible developers.

Plastic or resin developers are characterized by their inherent ability to produce a high resolved penetrant indication in a strippable plastic film which can be stored as a permanent record if so desired. Chemically, the plastic film developers are composed of a variety of organic polymers of varying molecular weights, dispersed or dissolved in selective solvents. Functionally, plastic — solvent developers act by dissolving penetrant from the flaw into the amorphous plastic film where it is fixed when all of the solvent is evaporated. To avoid masking fine defects, a fine coating of white lacquer is applied first and then plastic film developer is applied by spraying in very thin light passes.

Most of the developers used with portable penetrant inspection kits are of the non-aqueous solvent type. These developers are in the form of pressurized cans and contain the necessary developer powder suspended in a volatile liquid medium. These cans should be thoroughly agitated before use to ensure the proper suspension of developer in solvent when applied to test parts.

3.5. Observation of indications

3.5.1. Lighting conditions for coloured liquids and UV radiation for fluorescent liquids

Visible penetrant indications can be inspected in either natural or artificial white light. According to ASME Code (Section V) the recommended minimum light intensity for visible dye indication to be inspected is 32.5 foot candles. Similarly for the inspection of fluorescent indications to be made under black light source, the allowed value of ambient white light is a maximum of 3 foot candles for critical inspection. It is recommended that the operator be in the darkened area for at least 5 minutes prior to inspection so that his eyes adopt to dark viewing.

For viewing fluorescent penetrant indications under black light, lamp intensity should be a minimum of $800 \mu\text{watt}/\text{cm}^2$ on the surface of the part. There is not a constant factor that relates milliwatt/ cm^2 to the candela/ cm^2 .

3.5.2. Sequence and time of observation

The length of time the developer should remain on the part prior to inspection should not be less than 7 minutes. Developing time begins as soon as the dry developer is applied and as soon as the wet (aqueous and non-aqueous) developer is dry (i.e. the solvent carrier have evaporated to dryness). If bleed out does not alter the inspection results, development period of over 30 minutes are permitted.

3.5.3. Interpretation of the findings and identification of the type of defects

By interpretation we mean to assess the cause of an indication or the evaluation of the significance of discontinuities from the stand point of whether they are detrimental defects or inconsequential blemishes. Penetrant indications provide the experienced operator with qualitative data on which to base a decision in all obvious cases. He must know the kind of flaw and its approximate magnitude before attempting to solve the problem of estimating probable damage to the part. If fluorescent penetrant is used and the examination is made under black light (ultraviolet), sound areas appear as a deep violet-blue, while discontinuities glow with a brilliant yellow-green light. If dye penetrant is used, the examination is made in ordinary white light, the developer forms a white back-ground and the defects are visible by a red colour indication.

Relevant indications

Relevant indications are those caused by discontinuities. The interpretation of an indication as relevant is a matter in observing the indication, eliminating the possibility of its being a false indication and then further determining that it is relevant.

A true indication immediately becomes subject to interpretation of the type of discontinuity and evaluation on the basis of the relevant acceptance standard or engineering decision based on the effect of the indicated discontinuity on the service life of the specimen. Definite appraisals require knowledge of the processes used in fabricating or in the case of a component in service, knowledge of its operation and the stresses to which it has been subjected.

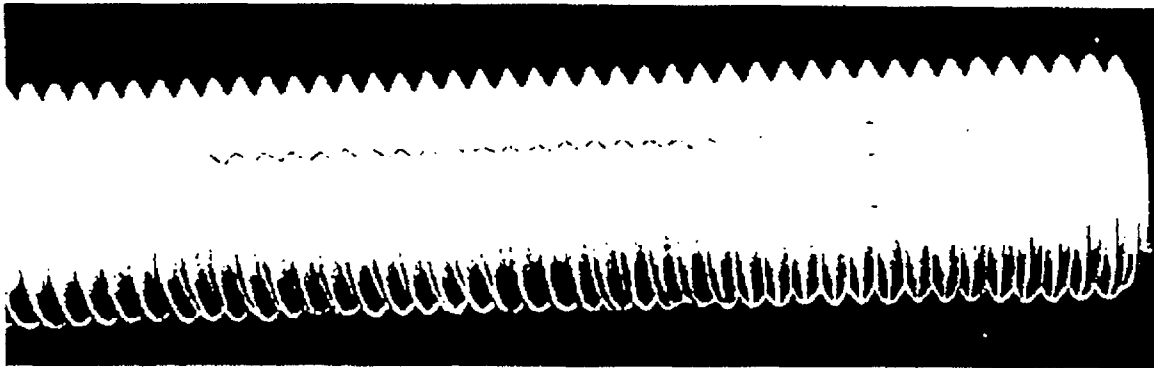

Figure 3.7: Relevant indications.

Discontinuity indications vary widely in appearance but for each indication two interpretative questions must be answered. What type of discontinuity causes the indication? What is the extent of the discontinuity as evidenced by the extent of the indication? Relevant indications fall into five categories; continuous line, intermittent line, rounded, small dots, and diffused or weak.

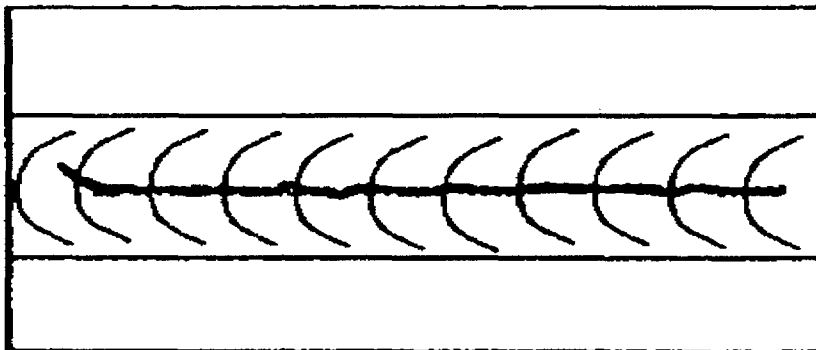

Figure 3.8: Continuous line.

Continuous line

Continuous line indications are caused by cracks, lack of fusion, incomplete penetration, forging laps, scratches or die marks. Cracks usually appear as jagged lines and forging laps as smooth, wavy lines. Scratches and die marks appear in a variety of linear patterns but are readily recognizable when all penetrant traces are removed. Seams provide a continuous line that differs from a crack in that the line is straight rather than jagged.

Intermittent line

The same discontinuities that cause continuous line indications may, under different circumstances, cause intermittent line indications. When an article is worked by grinding peening, forging or machining for example; portions of the discontinuities in the surface of the article may be closed by the metal-working process. When this occurs, the discontinuities will appear as intermittent lines. Very light cracks yield similar signs.

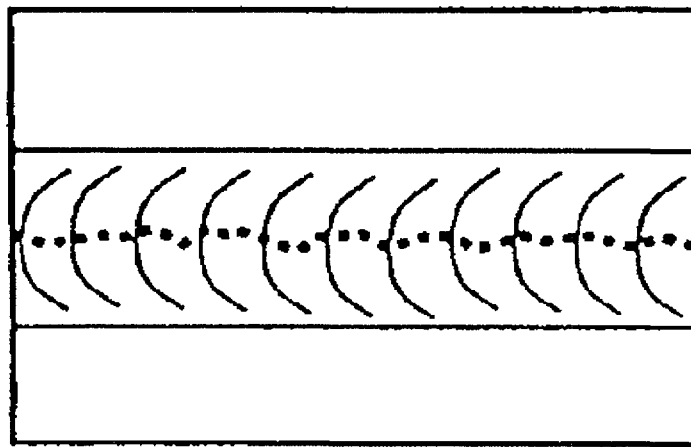

Figure 3.9: Intermittent line.

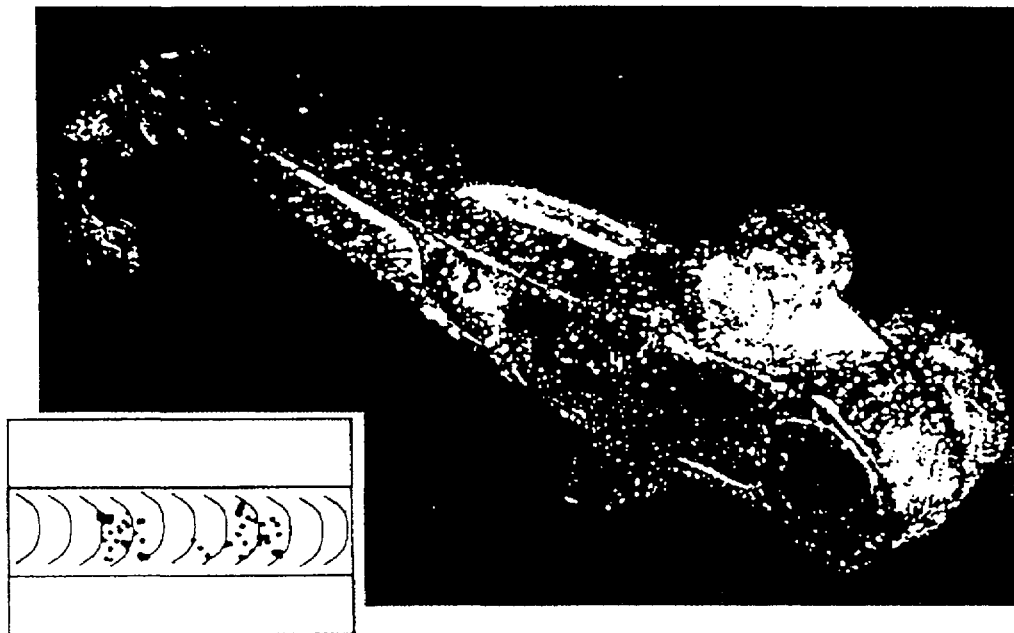

Figure 3.10: Round indications.

Round

Round indications usually are caused by porosity. The porosity may be the result of gas holes or pin holes. Deep cracks may also appear as round indications since they trap a large amount of penetrant that spreads when the developer is applied.

Small dots

Small dot indications result from fine openings such as pin holes, or may be the result of coarse grain in a cast alloy.

Diffused or weak indications

Diffused or weak indications are particularly difficult to interpret. When they appear, the workpiece is to be thoroughly cleaned and re-tested. While weak diffused indications may be caused by surface porosity, they are more often the result of insufficient early cleaning incomplete penetrant removal or too thick a layer of developer.

3.5.4. Spurious or non-relevant indications

False indications

False indications are those which are not associated with a discontinuity of any sort. The most common source of false indications is poor washing of water-washable and post-emulsifiable penetrant. When using fluorescent penetrant, the use of black light during the washing process is very important.

The operator can easily tell whether a good rinse is obtained by noting whether patches of fluorescence remain on the specimen. Care must be taken so that no outside contamination occur.

Typical sources of contamination are:

- (1) Penetrant on hands-off operator.
- (2) Contamination of wet or dry developer.
- (3) Penetrant rubbing from an indication on one specimen to the surface of another specimen.
- (4) Penetrant spots on the inspection table.
- (5) Lint or threads.

Non-relevant indications

As well as the truly false indications there is a category of non-relevant indications which testing personnel can recognize. These are true indications in the sense that they are caused by surface design and therefore not flaws. Most of such non-relevant indications are easy to recognize since they are related directly to some feature of the assembly that accounts for their presence. They include those that appear on articles that are press-fitted, keyed, splined, riveted or spot welded and those appearing on castings as a result of loosely adherent scale or a rough surface due to burned-in sand. Such non-relevant indications must be carefully noted, since they may interfere with correct interpretation.

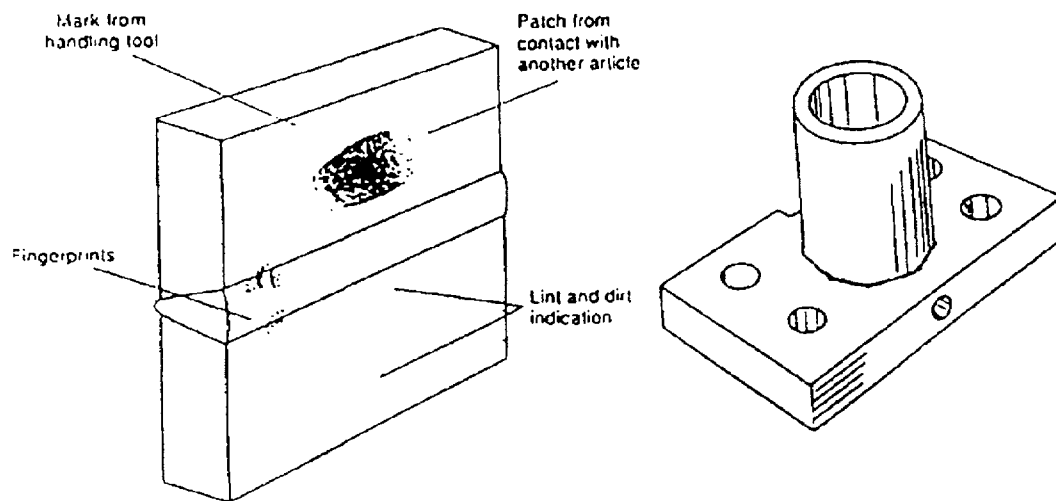

FALSE INDICATIONS

Figure 3.11: False indications.

3.6. Recording of findings

3.6.1. Test report forms

The test report forms should contain the necessary information on the type of chemicals used and the methods employed. The indication observed have to be categorized as linear or rounded. Linear indications are those in which the length is more than three times the width. Rounded indications on the other hand are those in which the length is equal or less than three times the width. The recording of indications as relevant should be made for those arising from unacceptable mechanical discontinuities. Only indications with major dimension greater than 1/16 inch (1.6 mm) are considered as relevant. The test report form should also indicate the location of defects.

3.6.2. Localization schemes

For welds the location of defect is determined by two co-ordinates L and W. L is the distance from certain mark of weld. W is measured from the weld centre line. The different sides of the weld are identified by letters A and B. The location of the defect is measured from the centre of the defect. The orientation of the defect is reported in relation to the weld. A defect shall be recognized as longitudinal if it is parallel to the weld and transverse if perpendicular to the weld. Figure 3.12 illustrates the scheme for localization of the defects.

3.6.3. Transfer of findings

For maintaining a record for later reference or presentation in a report the respective indications can be transferred into sketch forms, photographs and diagrams. Such diagrams should illustrate the location, direction and areas of discontinuities. Recording of such indications for report writing purposes are through a transparent cellulose tape transfer method.

3.6.4. Photographic techniques

Liquid penetrant indications observed using visible dye or fluorescent dye can easily be photographed. For fluorescent penetrant indications use of black light filters has to be made. The

3.6.4. Photographic techniques

Liquid penetrant indications observed using visible dye or fluorescent dye can easily be photographed. For fluorescent penetrant indications use of black light filters has to be made. The specimen test area is under black light which help pronouncing the indication through their fluorescence. A typical photographic arrangement for this purpose is shown in Figure 3.13.

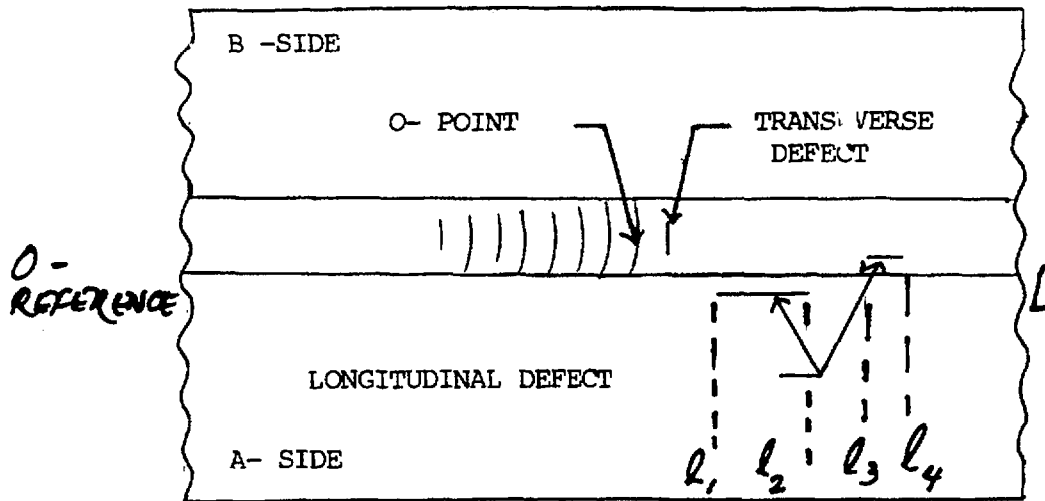

Figure 3.12: Location of defects in welded job.

3.6.5. Writing reports

The inspection report should contain complete information detailing the size, number and location, of indications as well as interpretation of the defect type. To assist in determining the acceptability of a component when working documents do not give acceptance criteria, it is necessary to know the position of the imperfections with respect to the most highly stressed areas. Sketches should be used to illustrate the location, direction and frequency of defects.

3.7. Testing techniques for detection of leaks by means of liquid penetrants

Testing for leaks is a distinctly separate application where penetrant inspection is very successful. Any thin walled casting, weld, or tank which must be leak proof in its final assembly may be inspected for leaks at any stage in its manufacture. The essential procedure of testing is to apply or coat one side of the assembly with penetrant and time is allowed for the penetrant to draw through the leaks by capillary forces. Any fine leak will show as a bright colour spot on the outer surface. Increased contrast is obtained by applying developer to this opposite face after the elapse of penetration time. The leak detected can be repaired before assembly or the part rejected before it has been expensively machined.

Penetration time depends on the nature of the leak and thickness of section. Coarse porosity in the path provides little capillary force and will slow up penetration by a considerable factor. Normal penetration rate is very rapid. The process works extremely well through thin sections such as welded sheet metal but rapidly drops in efficiency through sections over 1/4 inch unless penetrant is applied under pressure.

It is important that the leaks must be free of foreign material. It is important that no water test be tried before using penetrant as the water will plug all the fine passages. Even pressure tests with high moisture content may markedly reduce later penetration by penetrant.

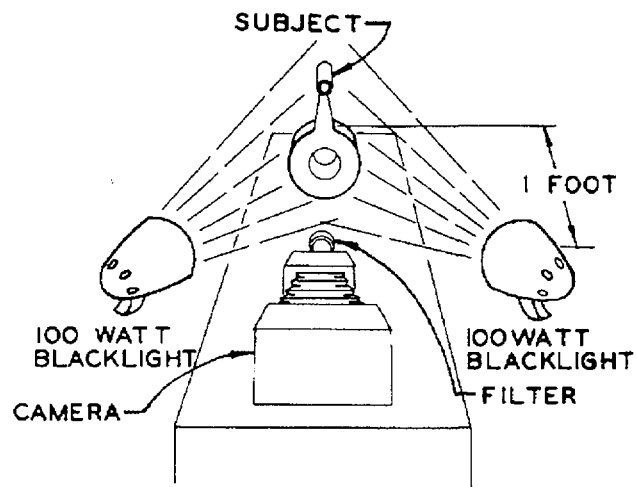

Figure 3.13: Diagram of set-up for black light photography.

4. TEST EQUIPMENT AND MATERIALS (PT)

4.1. Evaluation of the materials used in the test

The reliability of any penetrant test is determined in large part by the condition of the materials used. Even the best procedures are worthless if test materials are faulty. Quality control of incoming penetrant processing materials, as well as quality control of in-use inspection materials on a periodic basis, is essential to a reliable penetrant inspection programme. Many simple tests are available whose use could ensure that liquid penetrants do meet the applicable quality standards, as they are received from their manufacturer. The overall performance capabilities are evaluated to check the following common properties.

- (1) Visual appearance.
- (2) Viscosity.
- (3) Specific gravity.
- (4) Thin film penetrant brightness or colour.
- (5) Sensitivity shown on penetrant comparators or reference panels.
- (6) Emulsifier tolerance for penetrant contamination.
- (7) Ease of washability of excess penetrant.
- (8) Infrared spectrophotometric analysis.
- (9) Water tolerance of penetrants and emulsifiers.
- (10) Wetting ability.
- (11) Bulk density for developers, or apparent gravity for suspensions of wet developers.
- (12) Flash or fire points.
- (13) Capillary rise.
- (14) Sulphur and halogen content.
- (15) Liquid oxygen (LOX) impact sensitivity.

Since many of the tests used in the control of penetrant materials are comparison tests in which “used” materials are compared with “new” materials, control samples are taken at the time the materials are received from the supplier. These samples are kept in sealed containers and stored where they are not subject to deterioration from heat, light, or evaporation.

4.1.1. *Penetrating agents*

Characteristic properties

Viscosity

There are a number of methods for comparing the viscosity of two materials such as a ball setting test or tests using instruments specifically designed for measuring viscosity. Such instruments are called viscometers. Water can radically change the viscosity of water-washable penetrants, depending on their water tolerance. Solvents or oils can increase or decrease the viscosity of penetrants.

The change in viscosity affects the speed of washing characteristics. The increase in penetrant viscosity will increase dragout on test parts, slow penetration into discontinuities, and change the wash characteristics.

Density/Specific gravity

Specific gravity is a comparison of the density of a penetrant with the density of distilled water at 4°C. This is a characteristic which has no direct influence on the penetrating properties of a liquid. Most commercial penetrants have specific gravity less than one. This is because the principal constituents of penetrants are organic liquids of naturally low specific gravity. Some of the non flammable colour contrast type penetrants have a relatively high specific gravity. One advantage of a specific gravity of less than one is that water which may get into a tank of penetrant during use will drop to the bottom of the tank and not tend to interfere with the proper functioning of the penetrant.

Surface tension

Surface tension of the liquid penetrant, resists capillary flow into a crack. Any liquid contamination affects the penetrability of the penetrant by modifying its surface tension. Since water has a much greater surface tension than most oil base penetrants, water contamination will result in an increased surface tension and a reduced infiltration capacity and test sensitivity.

It is difficult to measure surface tension by any simple test; however, it is closely related to the contact angle and wettability, as discussed in Section 2. There are two tests that can be used to compare the wettability of a penetrant: (a) a drop test on a flat surface and (b) a capillary test using capillary tubes.

a) The drop method

The liquid is allowed to drop through a capillary orifice. The size of the drop is governed by the surface tension of the liquid. The instrument used is called stalagnometer. It is a pipette with a capillary tube at lower end as shown in Figure 4.1. The tube is thoroughly cleaned and the liquid is sucked up to the mark A. The drops are counted for the liquid between marks A and B.

The surface tension of the liquid is measured by using the relation:

$$T_1 = (\rho_1 n_2 / \rho_2 n_1) \times T_2 \quad (4.1)$$

Where n_1 and n_2 are the number of drops formed for volume of liquids between A and B.

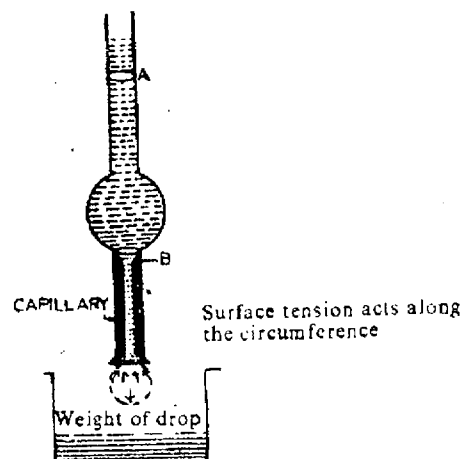

Figure 4.1: A stalagnometer.

b) The capillary rise method

Surface tension enables a liquid to rise up in a capillary tube. This phenomenon can be used for its measurement. When a clean capillary tube of radius r is dipped into a liquid in a beaker, the liquid will rise up the capillary to a height h , till the force due to surface tension which pulls the liquid upwards is counter balanced by the force of gravity pulling it downward. The surface tension T of the liquid with density ρ is given by the formula:

$$T = 1/2 (h + r/3) \rho g r \quad (4.2)$$

Ignition point

A satisfactory commercial penetrant should have a high flash point. Flash point and fire point should not be confused. Flash point of a liquid is defined as that temperature at which sufficient combustible vapour, under standard conditions, is given off to form an explosive mixture with the air immediately over the liquid when a flame is present. Fire point a higher temperature is the point at which the liquid will take fire and continue to burn if a flame is introduced into the vapour cloud over the liquid surface.

Flash points of volatile liquids are usually measured in an apparatus called the "tag" closed cup, or in a similar one called the Pensky-Martens closed cup. Closed cup flash points are lower than open cup flash points, since the former apparatus prevents stray air currents from blowing vapours away, and instead collects them in a closed chamber. Usually the tag closed cup test is used up to 175°F (80°C), while the Cleveland Open Cup Test is used above 175°F.

In the Tag closed test the liquid is placed in a brass container or cup heated electrically or by a gas flame at a specified rate. The cup is covered, the cover supporting a fixture which holds the thermometer with bulb in the liquid and supports the small test flame. At intervals, by moving a lever, a window in the cover is opened and the test flame brought to the opening. The temperature is recorded when this application of the flame ignites the vapour in the cup.

A penetrant with a low flash point may give off enough vapour when it gets warm, to "flash", over the surface with explosive force if a flame is brought near it and penetrants do get warm, from mere ambient heat in the shop or from immersion of hot parts fresh from a vapour degreaser. Low flash point liquids almost invariably have a low fire or ignition point and so constitute a definite fire hazard.

The flash point of a liquid affects the conditions under which it may be shipped in interstate commerce. Liquids with flash points lower than 80°F open cup (which corresponds usually to 60°F to 70°F closed cup) are classed as flammable, require a special red label, and must be shipped in small quantities by railway express or air freight. If the flash point is lower the restrictions are stiffer. Table 4.1 illustrates flash point values of some liquids. Many industrial and government specifications now limit the flash point of a desirable penetrant. It is considered that, under the average conditions of industrial use a penetrant with a closed cup flash point of 130°F or over is not a very serious fire hazard.

Halogen and sulphur content

When using penetrant inspection materials on austenitic stainless steels and titanium alloys total chlorine fluorine contents and for nickel base alloys sulphur contents shall be considered. Even though penetrants and processing materials are removed following inspection, residues may be retained in crevices, joints and blind holes or other inaccessible areas. With inadequate cleaning, such residues may react detrimentally with the alloy surface after the components are

placed in service. The continued incidence of stress-corrosion cracking in austenitic stainless steels has focused the attention on the halogens and sulphur content in liquid penetrant materials used for non-destructive testing. ASME (American Society of Mechanical Engineers) Boiler and Pressure Vessel Code limits the presence of the sulphur and chlorine contents to 1%. The same has to be determined/ analysed in accordance with the methods described in standards ASTM D129 and D808.

TABLE 4.1: FLASH POINTS OF DIFFERENT MATERIALS.

Material	Flash Point F-closed Cup	Material	Flash Point F-closed Cup
Ethyl Ether	-49°	Stoddard Solvent	100°
Carbon Disulphide	-22°	Cellosolve	104°
Acetone	0°	Cyclohexanol	154°
Ethyl Acetate	24°	Ethylene Glycol	232°
Naphtha	30°	Di-butyl phthalate	315°
Toluene	40°	Glycerine	320°
Methyl Alcohol	54°	SAE-10-Lub-Oil	450° (open cup)
Ethyl Alcohol	57°	Chloroform	Non-flammable
Turpentine	95°		

Colour

Visible dye penetrants contain red dye as tracer to give optimum contrast for high sensitivity inspection. This gives a red indication against the white background of the developer. The red visible dyes are stable, inert pigments; their concentration in the penetrant influences the total sensitivity. The dye concentration can be compared with a standard sample by using a light transmission comparison.

Fluorescence

Inspection with fluorescent penetrants is highly sensitive. In such penetrants the tracer is of or coated with fluorescent material. The fluorescent material absorbs the black light and re-emits the absorbed energy as visible light in the yellow green region of the visible light spectrum.

Fluorescent dyes have a number of properties that, if changed, can reduce the fluorescent brightness and, thus, the overall sensitivity. Contamination and exposure to sunlight or black light can cause the following conditions:

- Loss of initial brightness.
- Loss of brightness after drying.
- Increase in fading rate when exposed to black light.

Behaviour

Drop expansion

One of the necessary condition for a penetrant liquid to enter into fine discontinuities is to wet the test surface and thus disperse evenly on it. Now for liquids of non-wetting type, the contact angle exceeding 90° , the high surface tension of the liquid contracts the liquid droplet into a ball with minimum area of contact with the solid surface. For liquids where contact angle is very large (near 170°), the liquid does not spread. On the contrary contact angles for most liquid penetrants and liquid leak tracer is very close to 0° .

Now for a liquid to spread over a solid surface, the spreading coefficient, S_{SL} is given by the equation 4.3. Figure 4.2 illustrates the schematic diagram of liquid drop on an ideally smooth, clean surface at equilibrium showing contact angle.

$$S_{SL} = \gamma_{SG} - (\gamma_L + \gamma_{SL}) \text{ (N/m)} \quad (4.3)$$

Where:

S_{SL} is the spreading coefficient of liquid on solid.

γ_L is the surface energy of the liquid - gas interface.

γ_{SL} is surface energy of the solid - liquid interface.

γ_{SG} is the surface energy of the solid - gas interface.

SI units for each of the above parameters are N/m (dyne/cm in cgs system).

A necessary, but not sufficient, condition for spreading of the liquid on the solid surface requires that the surface energy of the solid — gas interface, γ_{SG} exceed the surface energy of the solid - liquid interface, γ_{SL} as indicated by the inequality.

$$\text{Spreading condition, } \gamma_{SG} > \gamma_{SL} \quad (4.4)$$

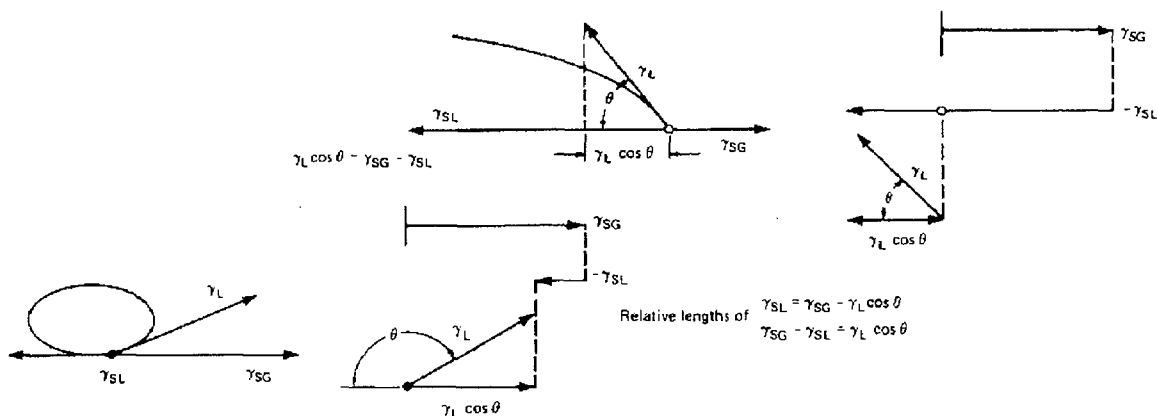

Figure 4.2: Schematic diagram of liquid drop on an ideally smooth, clean surface, at equilibrium, showing contact angle θ . With poor wetting, liquid drop has large contact angle θ , while with better wetting, liquid drop has smaller contact angle θ .

Washability

One of the requirements for a good penetrant is its washability. It should be soluble in water or a solvent or should become water washable through emulsification action. To achieve maximum contrast between indications and background, excess surface penetrant must be readily removable. In the water washability test, the washability performance of the penetrant being tested is compared to that of the reference penetrant. The penetrants are applied to separate test panels. After normal dwell and draining periods, and emulsification (if applicable), the penetrants are washed from the panels using a uniform water spray. If washing is found to be difficult, or retention of background dye is noticeably different from that of the reference penetrant, the penetrant is discarded.

Corrosion

Liquid penetrants are also incorporated with corrosion inhibitors among other additives. This is done so as to prevent the deterioration of the metal by their chemical or electrochemical reaction with its environment. Control of residues percentages and of halogen contents is of special importance in selection of a particular penetrant for a specific job.

Preservation

Proper maintenance is more difficult with liquid penetrants that are used in the open tanks where parts are dipped into them than when sprayed from storage cans. When expended as used particularly in the small portable kits, liquid penetrants are subject to very little contamination or degradation. There are also temperature limitations applicable to liquid penetrants. Test temperatures may vary widely with inspection conditions but must not exceed limits. Penetrants used in open tanks can withstand temperatures of up to 40°C (100°F) and above. If the penetrant is heated to a point where some of its light constituents are driven off its flaw detection capability will be greatly reduced. Prolonged exposure to elevated temperatures will degrade the fluorescence or visible dyes in penetrants, greatly reducing them to a level below which they are visible.

Materials packaged in aerosol spray containers are also not affected by normal storage conditions. Cold storage reduces the internal pressure so the can must be warmed to nearly room temperature to spray properly. Conversely, high storage temperatures raise the pressure, and extremely high pressures can cause bursting of the can. Therefore, aerosol can temperatures should never exceed 55°C (130°F).

Aerosol packages do not have infinite shelf life, largely because there is always some slight leakage of propellant through the valve. This leakage normally does not cause a significant change of spray performance until at least 2 years after the date of manufacture, but eventually there will be a loss. Some cans may be completely depressurized after storage for 3 to 5 years.

Stability under light and ultraviolet radiation

Penetrants are exposed to the ultraviolet radiation contained in ordinary light when kept in open tanks. They are again so exposed during the draining or penetration time after they have been applied to surfaces of parts. Black light is used during the step of washing or cleaning so as to ensure satisfactory removal of penetrant. Black light is again applied during inspection and in many cases a part is examined more than once under black light before its disposition is decided. Progressive loss of fluorescent intensity during this process is obviously highly undesirable and could be critical, especially in the case of very fine cracks. Fortunately the best dyes which have

been developed for penetrant uses, do have excellent resistance to fading under black light, though nearly all show some fading under such exposure. The poor dyes, however, fade so rapidly that they are generally unsatisfactory for penetrant purposes for this reason.

The fluorescent brightness test is usually performed with a modified photofluorometer. In this test, a small amount of the penetrant to be tested and the reference penetrant are diluted with a nonfluorescent highly volatile solvent such as methylene chloride. Test papers, cut to fit the sample holder of the photofluorometer, are then dipped into the solutions, withdrawn, and allowed to air dry. Following drying, the samples are placed in a preheated oven at 225°F (107°C) for 5 minutes. Five samples are prepared of the penetrant being tested and six of the reference penetrant (the extra reference penetrant sample is used as the master for setting up the photofluorometer). The samples are then alternately read on the photofluorometer and the results compared. If the fluorescent brightness of the penetrant being tested should drop below 85% of the reference penetrant, the penetrant is discarded.

4.1.2. Removers

Characteristic properties and behaviour

Removers are used to wash off excess penetrant and also as a precleaning/post cleaning agent. They can be water or solvent type depending upon the type of the penetrant.

In solvent cleaning test objects are immersed and soaked in tanks of common organic liquid solvents. Organic solvents are normally used at or near room temperature. Oil, grease and loose metal chips are removed from metal surfaces with or without agitation. After solvent cleaning, the parts are dried at room temperature or by external heat. Since contamination removed from test parts is retained in the solvent, both cleaning efficiency and the final cleanliness of test objects can decrease with continual use. Nearly all metals and alloys can be cleaned in common solvents unless acid or alkaline contamination is introduced into the solvents. Solvent cleaning is often used in combination with separate acid or alkaline cleaning procedures for removal of complex soils. Common organic solvents include aliphatic petroleum and chlorinated hydrocarbons similar to those used in vapour degreasing or blends of two or more solvents. Aliphatic petroleum include such familiar fluids as kerosene, naphtha, mineral spirits and Stoddard solvent. Other solvents include alcohol's (ethanol, methanol or isopropanol), ketones, benzol, toluol, 1, 1, 1, trichloroethene, and glycol ethers, as well as unsaturated chlorinated hydrocarbons such as trichloroethylene.

Portable penetrant kits for field use usually contain spray cans of penetrant, developer, and cleaner/remover. The cleaner/remover serves a dual purpose. It may be used to (1) clean the surface before penetrant application, although other stronger solvents are also used for precleaning in the field, or (2) remove the excess surface penetrant upon completion of the penetrant dwell time. When used to preclean, the spray solvent should be applied liberally and may be sprayed directly on the surface to be cleaned. Contaminant and excess solvent can then be removed from test surface with dry, lint-free cloth or paper towels. Adequate time to permit evaporation of the remaining surface solvent must be allowed prior to penetrant application. When solvent removers are used for removal of excess penetrant, caution must be exercised to prevent removal of the penetrant from shallow flaws. The solvent should be applied sparingly to a cloth which is then used to wipe off the excess surface penetrant. Never spray solvent directly on the part surface to remove excess penetrant.

4.1.3. Emulsifiers

Characteristic properties and behaviour

Emulsifiers are liquids used to emulsify the excess oily penetrant on the surface of the part, rendering it water washable. There are two basic types of emulsifiers. Oil based and water-based (detergent removers) both of which can act over a range of time from a few seconds to several minutes, depending on part surface, viscosity, concentration and chemical composition. Oil based emulsifiers function by diffusing (dissolving) into the excess penetrant on the surface of the part and rendering it water washable. The rate of diffusion establishes the emulsification time. Water base emulsifiers (detergent type removers) are normally supplied as concentrates, to be diluted with water and used as dip or spray. Water based emulsifiers function by displacing the excess penetrant film from the surface of the part through detergent action. The force of the water spray or air agitation of open dip tanks provides the scrubbing action while the detergent displaces the film of penetrant. The emulsification time will vary, depending on the concentration of the detergent in water.

Sensitivity test

The emulsifier sensitivity test is performed on aluminium comparator block, ceramic test block, or anodized test plate. After processing the indications panels are visually compared, if a noticeable difference exists the emulsifier is discarded.

Contamination test

The principal contaminant of emulsifiers held in open tanks is the penetrant. To limit this contamination, a fluorescence test is periodically performed. In this test, two blends of emulsifier and penetrant are prepared. The first blend consists of 75% new emulsifier and 25% new penetrant. The second blend consists of the same percentages of used emulsifier and penetrant. The samples are applied to separate test panels and permitted to drain at a 45 degree angle for 15 minutes.

The “used” penetrant-emulsifier test panel is then dipped momentarily in the emulsifier being tested; the reference panel is dipped in the reference emulsifier. The dwell period used will depend on the emulsifier but it usually ranges from 3 to 30 seconds. Then, using a special spray apparatus and a 20-grain hard water solution and 5 pounds air pressure (34 kPa), the panels are rinsed for 30 seconds with the spray nozzle held 90 degrees to the surface and 12 inches (305 mm) away.

Following the rinse, the panels are dried in a warm air dryer, after which (if applicable) the appropriate developer is applied. The panels are then compared under black light. Should the residual fluorescence of the used penetrant-emulsifier combination noticeably exceed that of the reference sample (by visual observation), the emulsifier is discarded.

4.1.4. Developers

Characteristic properties and behaviour

Developers when applied after the removal of excess penetrant from test surface help in drawing out the entrapped penetrant from the surface-open discontinuities. Developers consist of fine powder which has the following functions.

- (a) It has a blotting action which serves to draw more penetrant from the surface open discontinuities.

- (b) It provides a reflective base over which the penetrant can spread and disperse, thus increasing the amount of penetrant covered surface exposed to eye.
- (c) The action of drawing out the entrapped penetrant is by solvent action in case of solvent type developers.

The characteristics required or desired in a good developer are:

- (a) The material must be absorptive so as to secure a maximum of blotting action.
- (b) It must not be itself fluorescent if used with fluorescent penetrants.
- (c) It must be easily removable after the inspection is completed.
- (d) It should be inert and non-toxic.
- (e) For purposes of storage and handling, as well as application, the powders should not be hygroscopic. This is of importance if the developer powder is stored in the humid atmosphere. This way they might lose ability to flow and dust easily.

Granulometry and apparent volume

Granulometry is defined as the measurement of grain sizes of sedimentary rock. A sediment is a mass of organic or inorganic solid fragment itself, that comes from weathering of rock and is carried by suspension or dropped by air, water or ice, or a mass that is accumulated by other material agent and that forms in layers on the earth's surface such as sand, gravel, mud, fill etc.

In case of powder particle, the apparent volume of the particle would mean its volume excluding open pores but including closed pores.

Sedimentation and compaction

Sedimentation is the method of analysis of suspension, by measuring the rate of settling of the particles under gravity or centrifugal force and calculating a particle parameter from the measured settled velocities.

Compaction is a technique for increasing the dry density of a granular material, particularly soil, by means such as impact or by rolling the surface layer. Process by which soil and sediment mass loses pore content in response to the increasing weight of overlying material.

Evaluation of processes

One of the basic and essential requirements of the wet developer is to form an even coating. The evaluation procedure involves checking the wetting ability and coating evenness. With large lumps occurring in developer coatings, small indications may be hidden under the lumps. If the coating does not cover the whole surface, indications in the uncovered areas will not be developed and rejectable parts may be accepted.

Developer baths that have lost their wetting ability can sometimes be brought back to working order by addition of more developer, or in special instance, by addition of the proper wetting agent. Usually, however the material must be replaced.

Another test for evaluating the performance of the developer in the penetrant process is the measurement of concentration of aqueous wet suspendible developer. The powder concentration in water suspensions generally range from 40 to 120 g of dry powder concentrated per litre of water. The specific gravity test for concentration is run by placing hydrometer directly in the developer tank or in a jar or cylinder. Any cracking of the developer coating during the drying operation in the normal inspection procedure indicates.

- A serious loss of water.
- An excessive over-concentration of the developer powder.

The third test that should be applied to wet developers is a check for fluorescence. Wet developer becomes fluorescent mainly from penetrant carried into it on test parts or which otherwise enters the developer. There is no way to reclaim penetrant contaminated developer so replacement is the only answer to such a problem.

Dry developer

Dry developers used in open tanks are usually tested only by observation. Since they are not hygroscopic, they do not absorb moisture from the air, and are relatively trouble-free if they do not come in contact with water. Any dry developer that is found lumpy or caked instead of light and fluffy, or that shows any other sign of having been wet, is discarded. Additionally the developer is visually examined for dirt. It is also checked under black light for fluorescent dry contamination. Should either condition exist, the developer is discarded.

Wet developer

Wet (aqueous) developers are usually tested only for proper density and possible contamination from dirt or penetrant. Specific gravity is measured with a hydrometer. If reading differs from specification requirements either powder or vehicle is added to the developer in sufficient quantities to bring the density within acceptable limits. Additionally, a small sample of the developer is taken from the tank and visually examined for dirt. It is also checked for fluorescent dye contamination under black light. If either condition is in evidence, the developer is discarded.

Use of standardized work pieces

The use of test blocks, plates, or panels is often specified in the performance of test procedures used in testing penetrant materials. Depending on the particular test, the materials used in the manufacture of test blocks include aluminium, steel, nickel, glass, and ceramic. Some of the blocks are designed primarily for checking penetrant or “system” sensitivity and performing comparison tests, etc., while others are designed specifically for testing penetrant or emulsifier washability. All, however, are prepared to rigid specifications as detailed in the following paragraphs.

Aluminium test blocks

Aluminium test blocks measure 2 by 3 inches (50 by 75 mm) and are cut from 5/16-inch thick (8-mm) bare 2024-3T aluminium alloy plate, with the 3-inch dimension in the direction of rolling. The blocks are heated non-uniformly and water quenched so as to produce thermal cracks. This is accomplished by supporting the block in a frame and heating it with the flame of a gas burner or torch in the centre on the underside of the block. The flame remains centered and does not move in any direction during the heating process. A 950 to 980°F (510 to 527°C)

Tempilstik, Tempilac, or equivalent, is applied to an area the size of a penny on the top side and directly in the centre of the block. The heat of the torch or burner is adjusted so that the block is heated approximately 4 minutes before the Tempilstik or Tempilac melts, after which the block is immediately quenched in cold water Figure 4.3. The same operation is then repeated on the other side of the block. A groove approximately 1/16-inch by 1/16-inch deep (1.5 by 1.5 mm) is cut in the 2-inch direction across the centre of the heat-affected zone on both sides of the block. This forms two specimen areas on each side of the block and permits the side-by-side application and comparison of two penetrants without cross-contamination. This type of block is widely used for comparing the performance of penetrants under actual crack-finding usage.

- (a) Preparation for use. Prior to use, aluminium test blocks are scrubbed with a bristle brush and liquid solvent, followed by vapour degreasing.
- (b) Preparation for reuse. After a test block has been used it is cleaned prior to reuse. The block is heated slowly with a gas burner to 800°F (426°C) as determined by an 800°F Tempilstik, or equivalent, after which the block is quenched in cold water. It is then heated to approximately 225°F (107°C) for 15 minutes to drive off any moisture in the cracks, and is allowed to cool to room temperature.

Ceramic test blocks

Ceramic test blocks are flat circular disks of unglazed ceramic that, although quite solid and impervious to liquids, have micro-pit surfaces that entrap liquid penetrants. Inasmuch as the micro-pit structure provides a range of pore sizes, a performance comparison can be made of two or more penetrants merely by noting the number or distribution of porosity indications and their brightness in a side-by-side comparison test. Indications appear as a large number of microscopic specks of fluorescence or colour, the number increasing as the sensitivity of the penetrant increases.

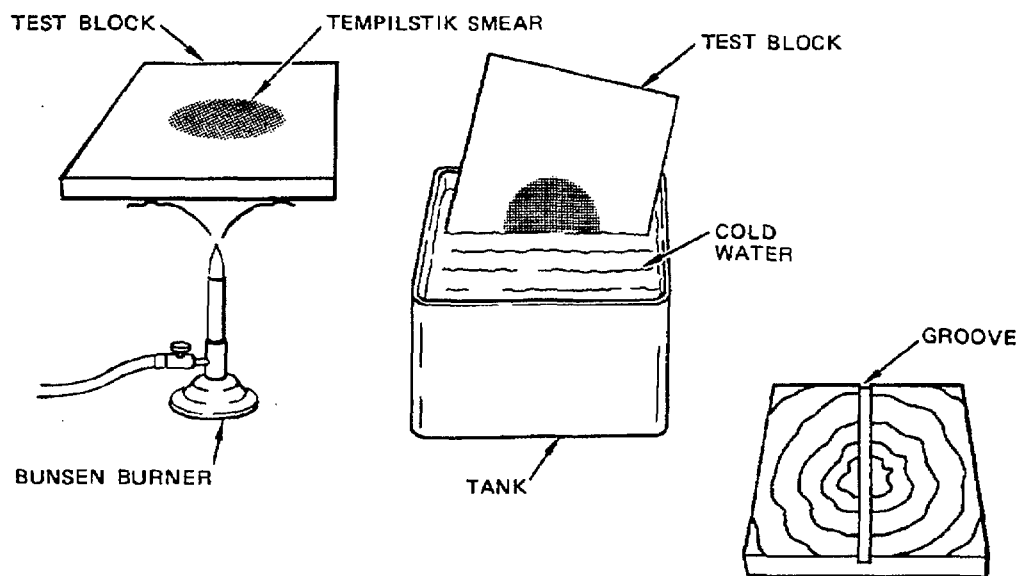

Figure 4.3: Heating and quenching of aluminium test block.

Preparation for use: The ceramic block is removed from its container (a shallow jar containing alcohol) using a pair of tweezers, or equivalent, to avoid touching with the fingers. The block is then wiped with a soft absorbent tissue, and allowed to dry 2 to 5 minutes.

Usage: Using a small applicator, a drop of each penetrant to be tested is applied to the flat surface of the test block. Immediately following application, the penetrants are blotted with a piece of soft tissue by pressing the tissue against the block using a glass platen or other flat object. This prevents the evaporation of the volatile materials in the penetrants from altering indications. The tissue and cover also hold the penetrants in proper contact with the test block and prevent excessive bleeding and possible cross-contamination. Following the required dwell period (usually 10 minutes), the penetrants are processed in accordance with the penetrant manufacturer's recommendations. A developer, however, is not used. In making visual comparisons, both the number of indications observed and the brightness of indications are noted.

Cleaning after use: After use, the ceramic block is placed on edge in alcohol and soaked for several hours or until the penetrant entrapments diffuse into the alcohol. The block is then returned to its storage container, covered with fresh alcohol, and sealed until again needed.

Anodized/Plated test panels

Stress-cracked anodized aluminium and chrome-plated nickel test panels are frequently employed in determining penetrant sensitivity and washability. The panels are classified according to the size of the cracks they contain. The grades are; coarse, medium, and fine. The coarse panels provide a low sensitivity level; the medium panels, a medium sensitivity; and the fine panels, a high sensitivity. The panel used depends on the level of sensitivity desired. See Figure 4.4.

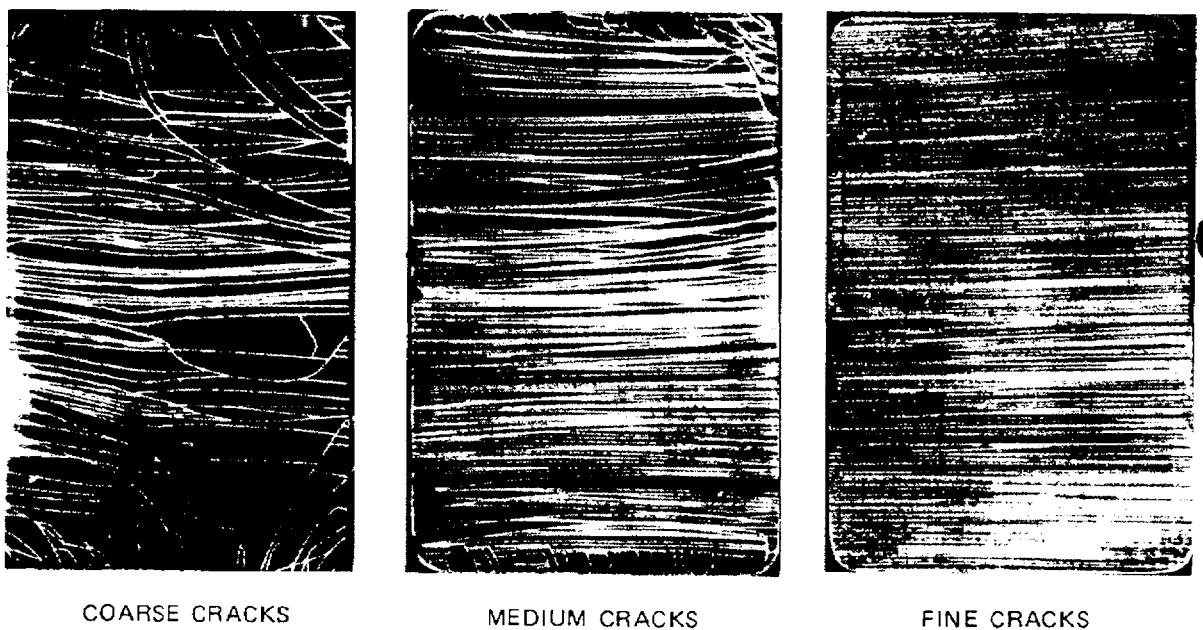

Figure 4.4: Fluorescent indications of stress cracks in chrome nickel test panels.

Preparation for use: Panel surfaces are scrubbed using moderate pressure and a cloth dampened with emulsifier or concentrated soap solution, and followed with a thorough rinsing using a water spray. Following rinsing, the panel is oven dried at 80 to 100°C for 3 to 5 minutes to drive off any moisture remaining in cracks. The panel is then dipped in acetone and agitated for a minute or so, removed, and again oven dried at 60 to 80°C for approximately one minute.

Usage: A line is usually drawn along the centreline of the panel and parallel to the length-wise dimension using a wax pencil or narrow vinyl tape. This forms two specimen areas and permits the side-by-side application and comparison of penetrant materials without cross-contamination.

Aluminium test panels

Aluminium test plates or panels are used in testing the washability of water-washable visible dye penetrants. The panels may be of any convenient size, 2 by 4 inches (50 by 100 mm) or larger, and are cut from clad aluminium alloy. The test surfaces are used in the “as-rolled” condition. Prior to use, the panel is degreased, after which it is heated to approximately 225°F (107°C), then cooled to room temperature in a dessicator.

Steel test panels

Steel test plates or panels are used in testing the washability of water-washable fluorescent penetrants, and visible dye or fluorescent penetrants involving the use of an emulsifier or solvent remover. The panels are prepared from annealed type 301 or 302 stainless steel and measure 2 by 4 inches (50 by 100 mm) or larger. Each is sandblasted on one side with 100-mesh average size grit, using 60 pounds air pressure (414 kPa), with the gun held approximately 18 inches (457 mm) from the surface. The sandblasting is continued until a uniform matte surface is obtained. It is the sandblasted surface that is used in performing tests.

Preparation for use: Prior to use, the panels are cleaned by vapour degreasing, heated to 225°F (107°C), and then allowed to cool to room temperature in a desiccator.

Cleaning for reuse: After each use, the panels are vapour degreased and resand-blasted.

Glass plates

One-quarter-inch thick (6 mm) glass plates (black for fluorescent penetrants and clear for visible dye penetrants) are also used to test the washability of penetrants. They are fabricated by sandblasting sheets of glass using 100-mesh average size grit at 60 psi air pressure (414 kPa), so as to provide a uniform matte surface.

4.2. Cleaning equipment

4.2.1. Degreasing vapour

One of the most common methods of preparing test parts for liquid penetrant inspection is vapour degreasing. This process is particularly suitable for removal of soluble organic contaminants such as mineral oils and greases. Unfortunately, vapour degreasing is not effective for removal of solid contaminants such as carbon, varnish, paints, scale, corrosion products or oxides. Other means of removal should be used instead of or in addition to vapour degreasing if any of these contaminants are involved. When steel or other ferrous metal parts are vapour degreased, the metal is usually highly susceptible to atmospheric corrosion if the air has high humidity or contains acid vapours, combustion products, or other corrodents. The hot vapours of

a chlorinated solvent such as 1, 1, 1-trichloroethane (which is less toxic than trichloroethylene or perchloroethylene) are used to remove oil, greases, or waxes from metallic test objects in preparation for penetrant inspection. An open steel tank contains the heated liquid solvent which boils and generates the solvent vapour. This vapour condenses upon the relatively cool metal surfaces of parts placed in the vapour zone above the heated tank. Some vapour degreaser units provide means also for immersing the test objects in the warm or boiling solvent or for spraying clean solvent upon the parts.

The preferred solvent is 1, 1, 1-trichloroethane (methyl chloroform) which boils at 72.2°C (167°F) This solvent eases parts handling problems during the later step of penetrant application, which is normally done at room temperature. During vapour degreasing, the contaminated solvent condensate drips back into the heated tank, carrying contaminants into the bath. During evaporation, only clean solvent vapours are produced, so that test parts are given adequate final rinsing in clean vapour. The test objects come out of the vapour degreasing operation both clean and dry, but warm. After adequate cooling, they are ready for application of the liquid penetrant, if no other forms of contamination exist. Figure 4.5 refers to a unit for precleaning by vapour degreasing.

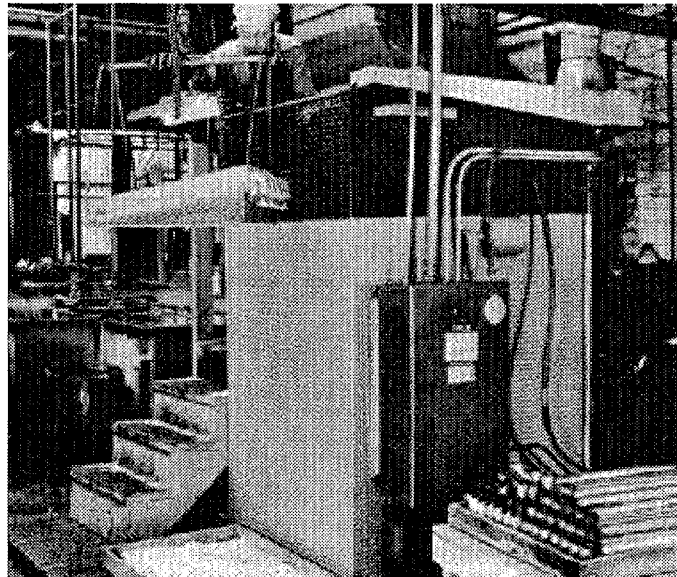

Figure 4.5: Commercial vapour degreasing unit.

4.2.2. Ultrasonic cleaning

Ultrasonic cleaning method adds ultrasonic agitation to solvent or detergent cleaning to improve cleaning efficiency and decrease cleaning time. It should be used with water and detergent if the soil to be removed is inorganic (rust, dirt, salts, corrosion products etc.), and with organic solvents if the soil to be removed is organic (grease and oily films etc.). After ultrasonic cleaning the parts should be heated to remove the cleaning fluid, then cooled to at least 125°F (52°C) before application of penetrant.

4.3. Compressed air equipment

4.3.1. Air filters

Automatic external drain air filter

They are used ahead of air tools, cylinders, valves and other pneumatic devices to filter out rust and scale particles and to separate water and sludge from compressed air systems. This helps prevent rusting and washing away of lubricants.

Oil remover filters

Where clean, oil free compressed air is essential, these coalescing filters do the right job. They remove more than 99.9% of oil mist over the entire operating line.

4.3.2. Supply of cold and hot air

There is a need of having supplies of cold and hot air available during penetrant inspection at the time of drying the parts after the removal of excess penetrant and for precleaned parts.

4.3.3. Compressed air pistols

Blow guns for compressed air are of different forms and purposes, few of the types are illustrated as under.

(a) Ionizing air pistols

Hand held, trigger actuated compressed air guns simultaneously clean and neutralize static charges on small or delicate parts. Once neutralized, contaminants will not be retracted.

(b) Safety flex air pistols

Air can be discharged from a controlled flow to full blast in any direction with a slight flex of the hose. When the hose is released, valve closes and shuts off the air flow. Please refer to Figure 4.6.

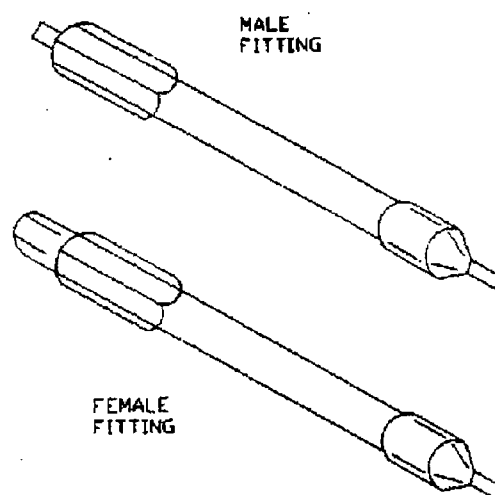

Figure 4.6: Typical flex air pistols.

4.3.4. Electrostatic pulverizers

Penetrants and developers may be applied by electrostatic spray. While the equipment is more costly than that required for immersion or normal air spraying techniques the method has the following advantages.

- (a) High speed operation.
- (b) No overspray.
- (c) Uniform coverage, which can be adjusted so that there is no drainage and only the minimum penetrant required for the process is applied. (Hence there is economy in the use of the high cost penetrant).
- (d) Absence of dust when spraying dry powder developer.

Principles of electrostatic spraying

The process is based on the fundamental law that electrically charged particles of opposite polarity attract one another, when these particles are placed within an electrical field they align themselves to the lines of force of that field. In practice, this electrical field is obtained by creating a potential difference between the workpiece, which is connected to ground, and the hand gun which is connected to the electrical generator. The negative charge on the particles is produced via a rotating atomizer in the liquid gun, and by a charged electrode surrounding the nozzle in the powder gun. The result is a wrap-around which allows all shapes of components to be evenly coated on the front and back with one pass of the gun.

Developers can also be electrostatically applied. However, solvents used as a vehicle in spray type developers should be non-polar or chlorinated.

The application of a high potential to the penetrant at the point of application has the following functions.

- (a) To cause the penetrant to break up into small electrically charged droplets due to the repulsion of electrical charges of the same sign. This may be assisted by discharging the penetrant from a rotating cup or disc and/or by the application of compressed air(though at a much lower energy than normal spray guns).
- (b) To produce an electrical field between the charged application and grounded component or area to be coated. The charged penetrant or developer particles then travel from the applicator to the grounded surface and since the field extends all around the grounded component, particles will deposit on the sides and behind the component giving the 'wrap around' effect.

As particles are deposited on the surface of the components they shield that particular area from the electric field, and deposition is enhanced on uncoated areas. Thus rapid uniform coverage is attained over the whole of the component or area.

Deep re-entrant shapes cause what is known as the Faraday Cage effect. This effect is the absence of charge on the inside of a hollow charged conductor. Thus, there would be no tendency for charged particles to enter such a region. This effect is overcome in practice by the use of a gentle compressed air assistance to the spray formation, giving the droplets sufficient energy to enter such charge free zones. An electrostatic gun for dry developer is shown in Figure 4.7.



Figure 4.7: Electrostatic spray application minimizes consumption of penetrant material and gives added assurance of full surface coverage. This technician is applying a fluorescent penetrant with a hand-held electrostatic spray gun.

4.3.5. Aerosoles

Penetrant materials such as penetrants, developers and solvent removers are also available in pressurized cans or aerosols. They have a storage life of about 2 years for normal use. Aerosol cans' temperature should however not exceed 55°C (130°F) as excessively high resulting pressures can cause their bursting.

4.4. Stationary installations for processing by immersion

The stationary equipment used in liquid penetrant testing ranges from simple to fully automatic systems and varies in size depending on the requirements of specific tests. Depending on the type of the penetrant and processing employed Figures 4.8 and 4.9, liquid penetrant test facility requires certain stations as shown in Figures 4.10 to 4.14.

4.4.1. Stations

In a typical testing facility for a post emulsification process, the following stations are required.

- Precleaning station, usually set at a remote place from the penetrant test station.
- Penetrant station (tank).
- Drain station (used with a penetrant tank).
- Emulsifier station (tank).
- Rinse station (tank).
- Developer station (tank).
- Dryer station (usually an oven type).
- Inspection station, enclosed booth or table with lighting facilities.
- Post cleaning (usually remote from penetrant test station).

Text continued on page 149

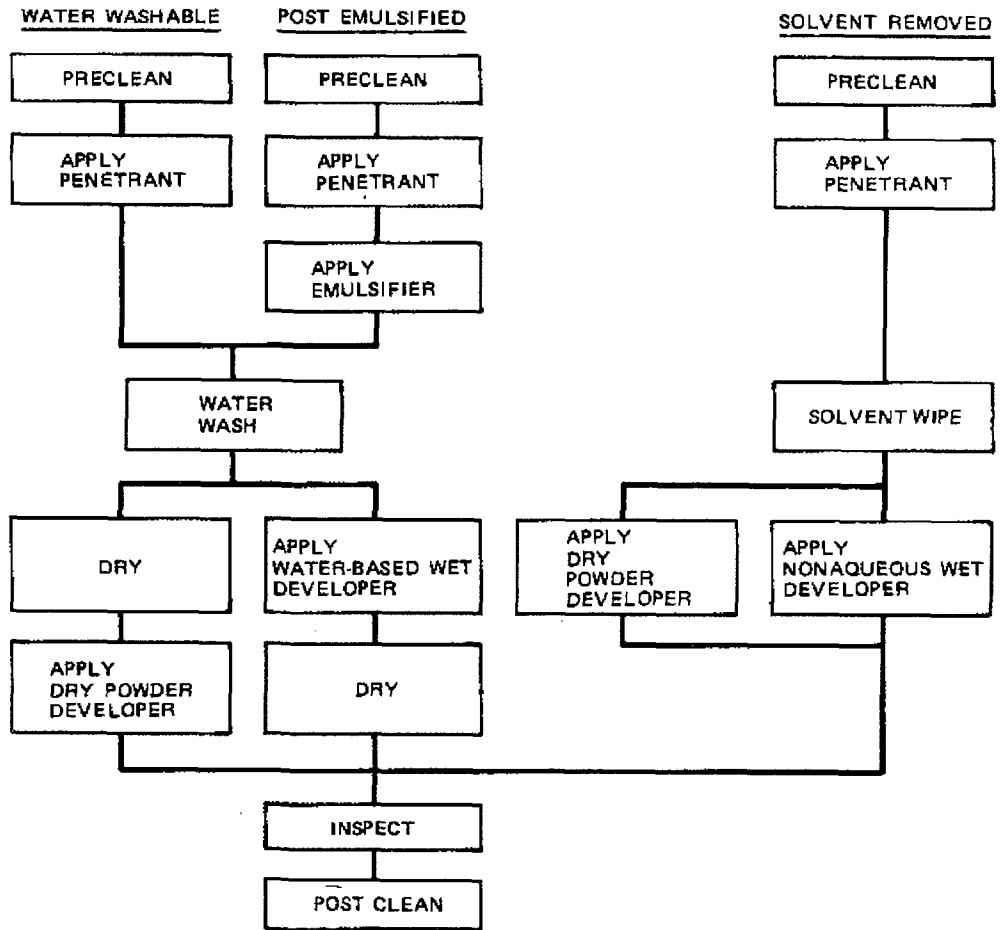

Figure 4.8: Visible dye and fluorescent penetrant process.

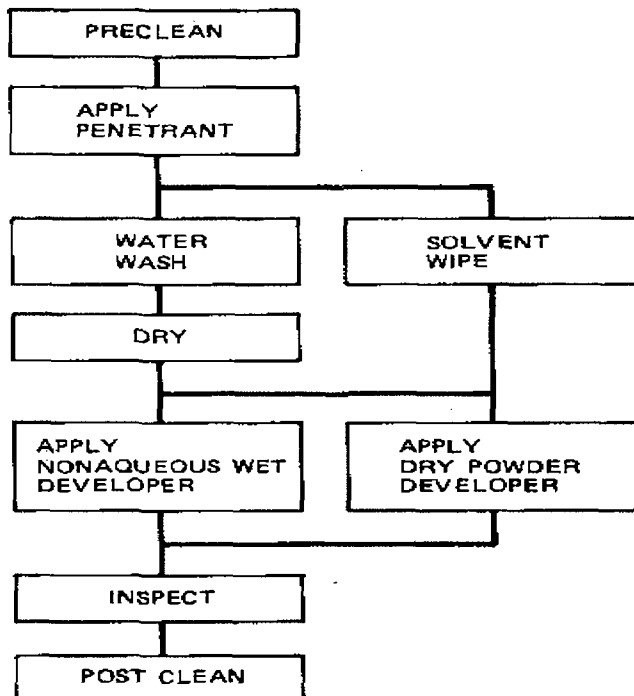

Figure 4.9: Dual sensitivity penetrant process.

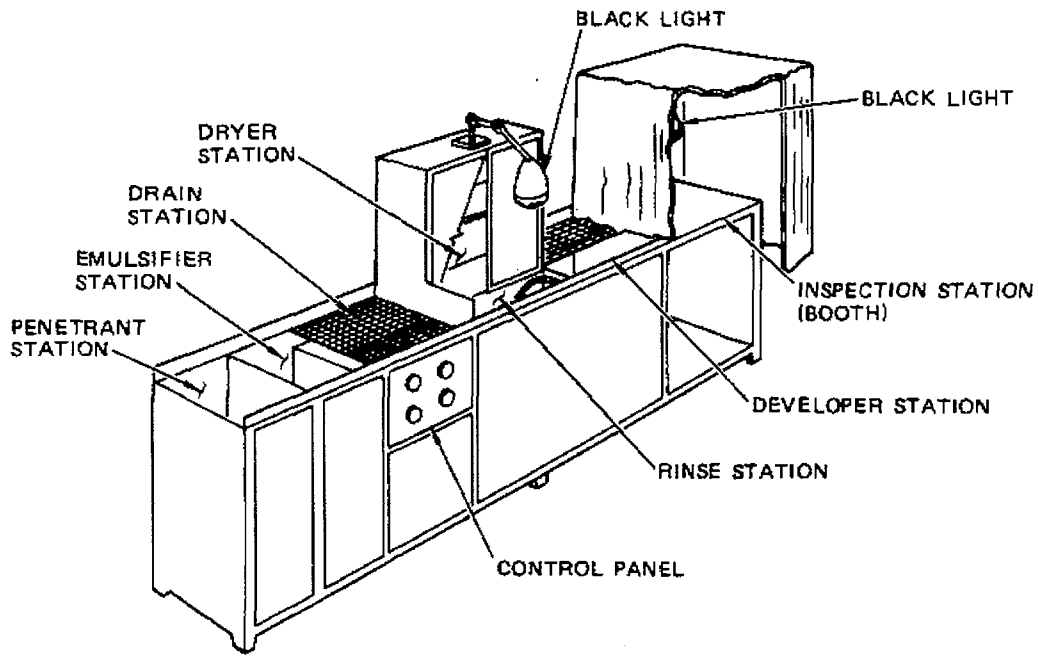

Figure 4.10: Typical small-sized test equipment employing fluorescent post-emulsified penetrant and dry developer.

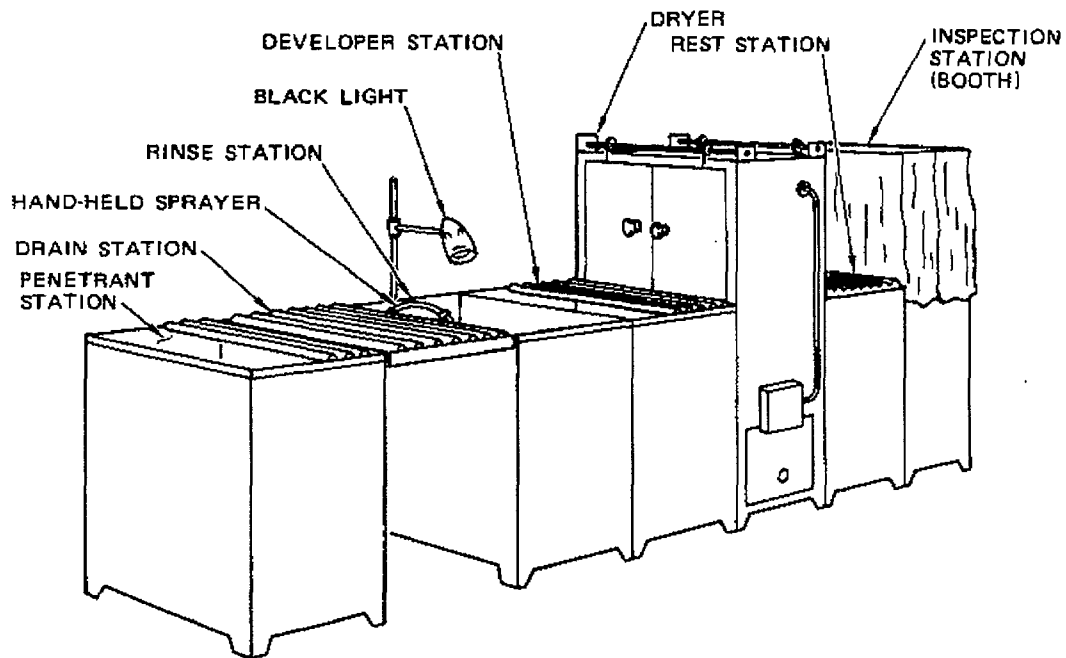

Figure 4.11: Typical medium-sized test equipment employing fluorescent water-washable penetrant and wet developer.

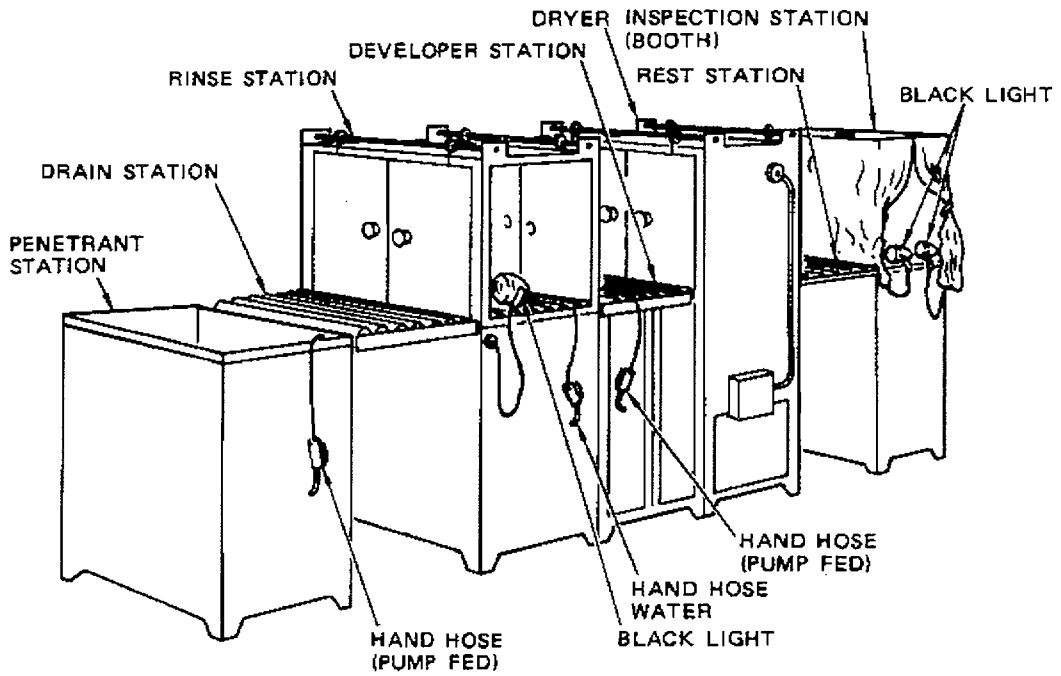

Figure 4.12: Typical large-sized test equipment employing fluorescent water-washable penetrant and wet developer.

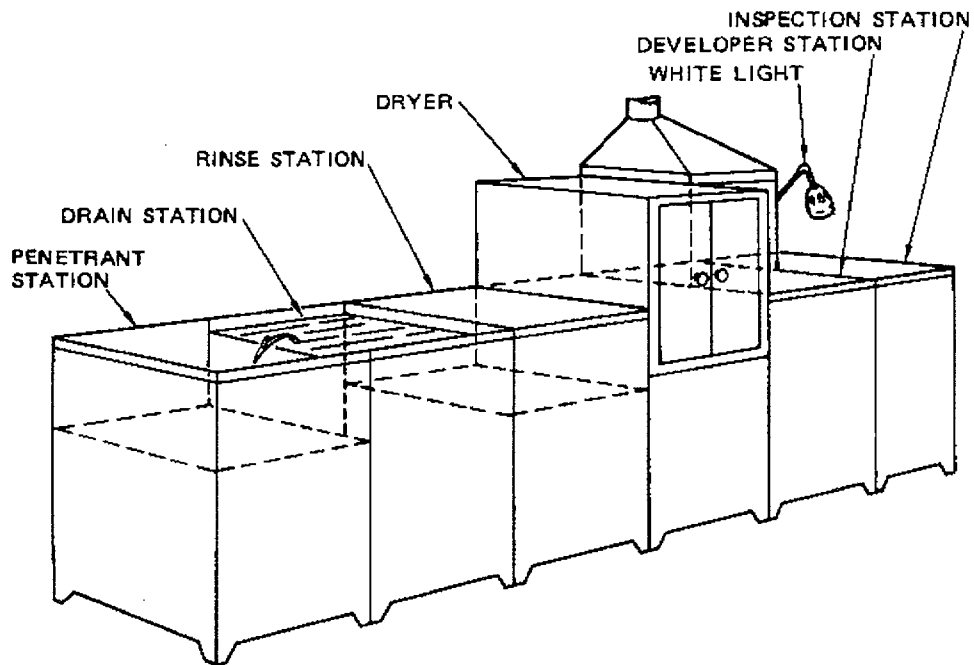

Figure 4.13: Typical medium-sized test equipment employing visible dye water-washable penetrant and dry developer.

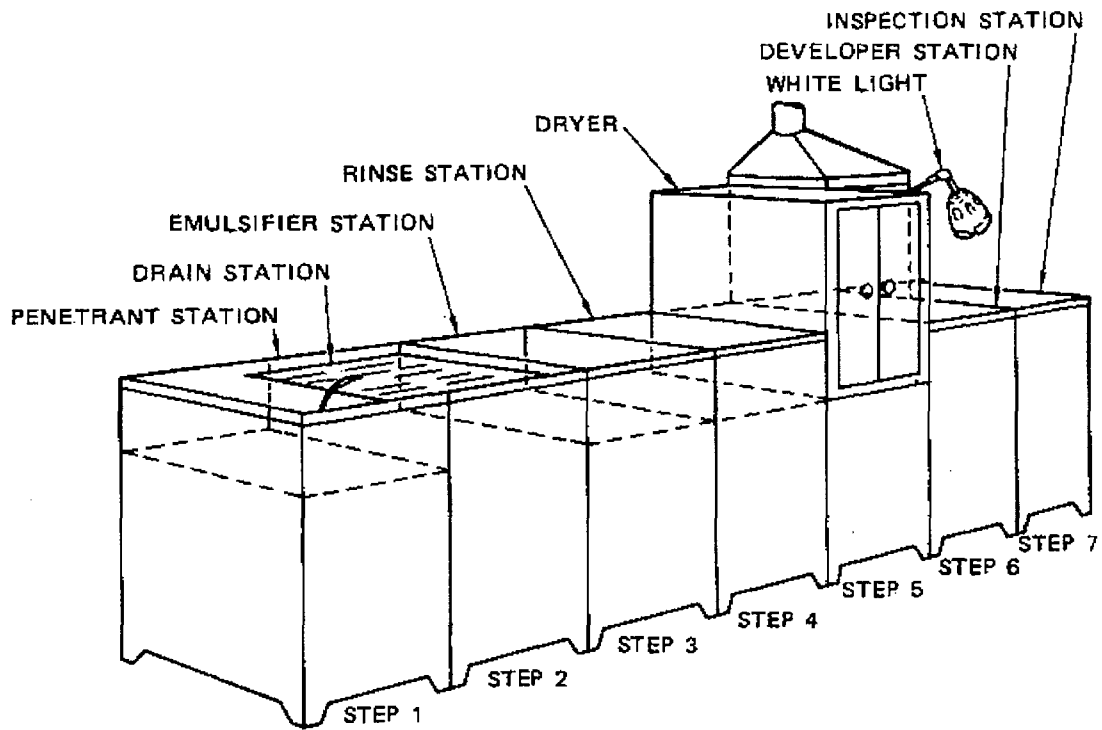

Figure 4.14: Typical medium-sized test equipment employing visible dye post-emulsified penetrant and dry developer.

4.4.2. Auxiliary equipment

Auxiliary equipment is defined as the equipment located at penetrant test stations (other than cleaning stations) required to perform penetrant testing. The auxiliary equipment being discussed below may be in some cases 'built in' at one or more of test stations.

Pumps

Various pumps installed at the penetrant, emulsifier, rinse, and developer stations are required to agitate the solutions, to pump/drain-off materials into the proper tank for reuse, and to pump hand held sprayers and applicators.

Sprayers and applications

Sprayers and applicators are frequently employed at the penetrant, emulsifier, rinse and developer stations. They reduce test time by permitting rapid and even application of penetrant materials and water rinse. Both conventional and electrostatic sprayers are used.

Lights

White lights as well as black lights are installed as required to ensure adequate and correct lighting conditions at all the stations. When fluorescent materials are used, black light is installed at both the rinse and inspection stations.

Timers

One or more 60-minute timer with alarm are used to control penetrant, emulsifier, developing and drying processes.

Thermostats and thermometers

These items are required and used to control the temperature of the drying oven and penetrant materials.

Exhaust fans

Exhaust fans are used when testing is performed in controlled areas to remove fumes and dust.

Hydrometers

The hydrometers as shown in Figure 4.15 are used to measure the specific gravity of the water-based wet developers. Normally floating type instruments are used.

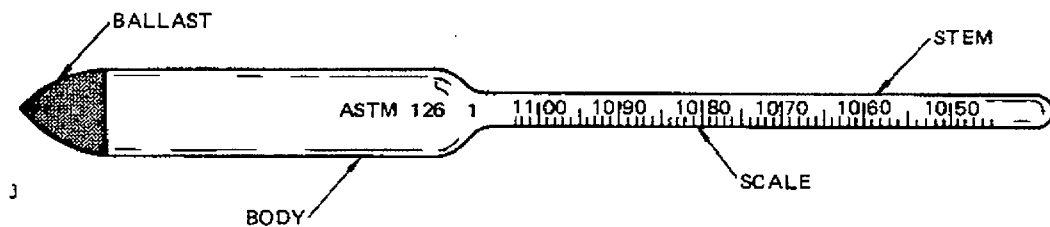

Figure 4.15: Typical hydrometer.

4.4.3. Automatic installations

Typical sequence of operations in automated penetrant inspection system

The use of automated systems for performing penetrant inspections of production aircraft and aerospace parts has become more common in recent years. Such systems have been installed at several aerospace companies to solve handling and inspection problems peculiar to their own situations. The following discussion outlines the basic components of a representative automated penetrant system for use with a fluorescent water washable penetrant. Figure 4.14 shows the typical sequence of operations in automated penetrant inspection of aerospace parts.

Techniques for handling of test parts

In a typical automated penetrant system, the parts to be inspected are initially racked on a load bar which is attached to an overhead conveyor system. The way in which the parts are racked is important in order for full coverage by the cleaning solutions, penetrant, water and developer to take place. Such factors as part size and geometry must be considered. If large varieties of parts are to be inspected in a typical inspection facility, it may be useful to develop technique cards for racking the parts to ensure that the inspection personnel rack a particular part the same way each time. The automated process is particularly effective for inspection of large numbers of simple geometry parts such as stringers but more complex parts can also be accommodated.

Automated pre-cleaning, rinsing and drying of parts

In order to prepare for application of the penetrant, the parts are first moved through a series of modules that apply the appropriate cleaning solutions. A typical sequence might be alkaline cleaning, tap water rinse, pickling tap water rinse, and deionized water rinse, as shown in Figure 4.16. Each chemical processing module is preceded and followed by an air knife. The function of the air knife is to prevent solutions from contaminating the previously applied solution or the next processing solution. After cleaning and rinsing a hot air knife with typical air temperature of approximately 80°C (180°F) is used to dry the parts thoroughly. Figure 4.16 is an illustration of automatic unit for penetrant inspection. The parts are moved through the processing modules at a controlled rate using continuously moving motor-driven, speed adjustable overhead conveyers. Automatic controls actuate the spraying systems of each module when the parts are positioned to utilize the sprays.

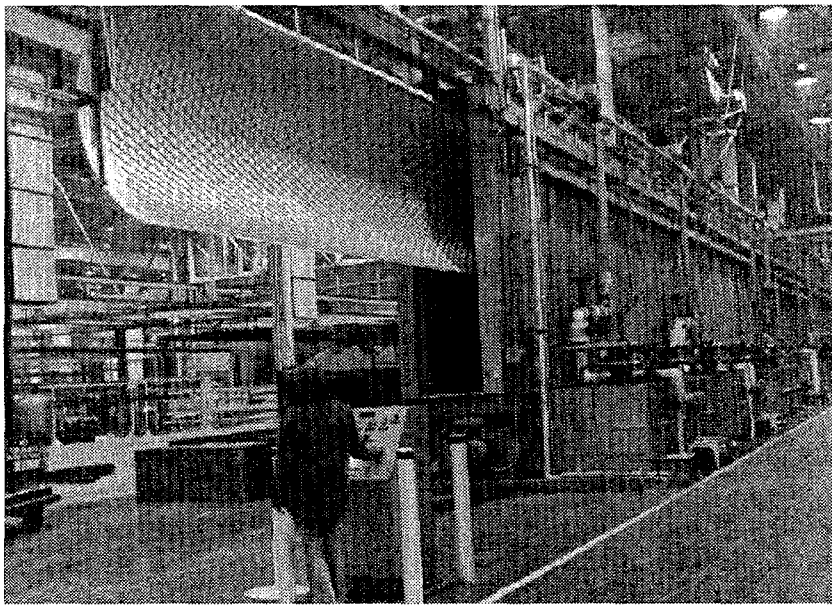

Figure 4.16: Automated aerospace penetrant spray processing and inspection system.

Automated electrostatic spray application of penetrants to parts

After the cleaning process, the parts are automatically moved into the module where the penetrant is applied. The spray guns may be installed to oscillate vertically or in any other suitable paths. The penetrant dwell time is controlled by the rate of movement of the overhead bar during transit from the penetrant spray modules to the water spray module.

Automated water spray for removal of excess surface penetrant

The parts rack automatically moves into a water spray module which removes excess penetrant from the parts. A series of adjustable water nozzles are commonly used in the module while air knives act to keep the water in the module. To prevent overwashing it may be necessary to conduct experiments to determine the proper wash water temperature, spray nozzle water pressure, time of washing, and positions of nozzles. Production parts with known crack or discontinuities or cracked reference panels could be used for this type of development programme.

Automated hot air drying, developing and visual inspection of parts

After the excess penetrant has been removed, the rack of parts is moved automatically into a hot air drying module where the air temperature is typically 80°C (180°F). Then, after application of developer, if desired, the parts are moved into a totally enclosed dark inspection room which has overhead black lights as well as hand held spot lights. Large parts can be lowered into a floor pit for ease of examination.

4.5. Light sources and light meters

4.5.1. Ultraviolet (UV) radiation sources (black light) and meters for measuring UV radiation intensity

The common sources of black light are:

- Incandescent lamps.
- Metallic or carbon arcs.
- Tubular 'BL' fluorescent lamps.
- Tubular 'BLB' fluorescent lamps.
- Enclosed mercury vapour arc lamps.

Because of low output, the first two types are not practically suitable for inspection. Similarly for low output of "BL" tubular fluorescent lamps, they are only usable in a very few special applications. However, both 'BLB' tubular fluorescent lamps and the enclosed mercury vapour lamps find many applications in fluorescent penetrant inspection.

Mercury vapour arc lamp sources of black light

Mercury vapour lamps are gaseous discharge devices in which an electric arc takes place in a controlled atmosphere and emits light whose characteristics depend on the nature of the atmosphere. The construction of a typical mercury vapour lamp is as shown in Figure 4.17.

Here, MC represents a quartz or hard-glass cartridge in which the mercury vapour is confined. E_1 and E_2 are the main electrodes that carry current to the arc stream which takes place along the length of the cartridge. E_3 is an auxiliary starting electrode. R represents a current limiting resistor. The entire assembly is sealed in an outer protective bulb, B, which may be either evacuated or filled with air or an inert gas, depending on the design of the bulb. The lamp is fed from a current regulating ballast reactance or transformer. This is required because the arc tube shows negative resistance characteristics and would quickly destroy itself if not throttled by an external device. A typical look of commercially available mercury arc black light source is as given in Figure 4.18.

A black light mercury arc bulb requires a housing and fixture:

- To support the filter.
- To prevent leakage of unwanted visible light and to permit the operator to direct the beam onto the area to be inspected. Mercury vapour arc lamps up to an intensity of 400 watt are also commercially available, but are normally not portable.

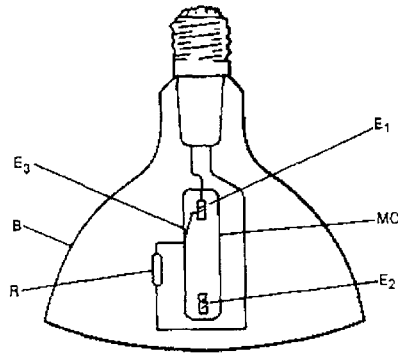

Figure 4.17: Mercury vapour arc bulb.

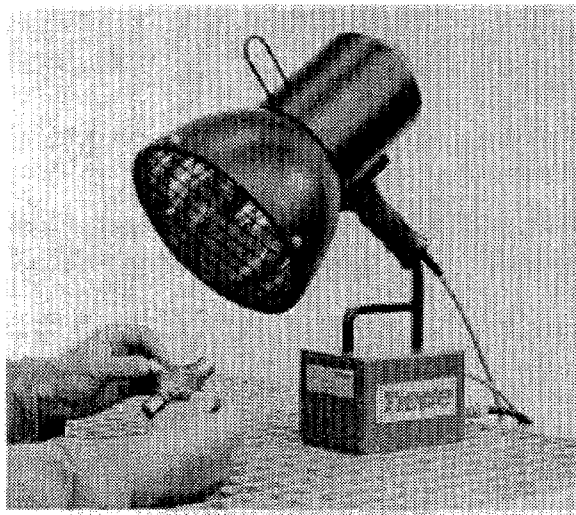

Figure 4.18: Portable 100 W mercury arc black light source.

Tubular fluorescent cold discharge black light sources

The second type of black light source used for inspection is the black light fluorescent bulb. Electrically and mechanically, these are standard fluorescent bulbs that come in sizes from 2 to 60 input watts and over. These cold discharge tubular lamps contain low-pressure mercury vapour glow discharges. Their primary radiation is hard ultraviolet of 253.7 nm (2537 Å) wavelength. This is used to excite a special cerium-activated calcium phosphate phosphor which is coated on the inside of the tube. This phosphor, when activated by the ultraviolet, emits black light with a range of 320 to 440 nm wavelengths peaking at 360 nm. Because a significant amount of visible light is emitted along-with the black light, these bulbs are often made of a purple-red filter glass similar to that used over the high-pressure arc lamps previously described. This greatly reduces the black light emitted, but still leaves what is often an excessive amount of visible blue light, considering the relatively low intensity of the black light produced. A look of commercially available such lamps is as shown in Figure 4.19.

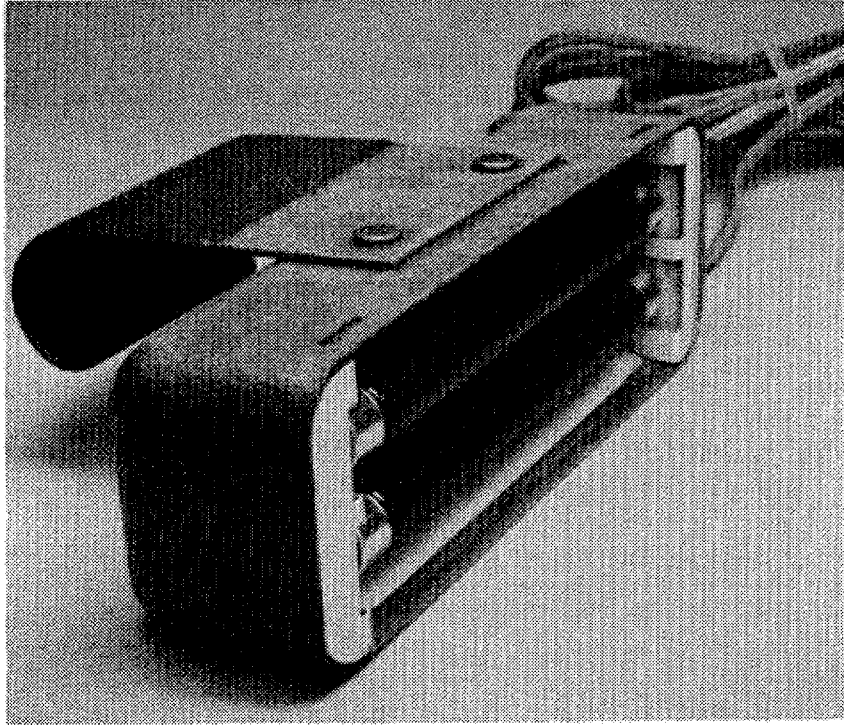

Figure 4.19: AC operated tubular low intensity black light.

Advantages and limitations of fluorescent tubular black light sources

Fluorescent black light bulbs put out reasonable amounts of black light, but because of their configuration they cannot be easily focused. Therefore, their intensity per unit area illuminated is much lower than that provided by the high-pressure mercury arc lamps. Thus, fluorescent black lights are not usually considered adequate for critical fluorescent penetrant inspections. Fluorescent lamp sources of black light for fluorescent penetrant inspection offer the significant advantages of instant starting, cool operation, and low cost as compared to the commonly used mercury arc lamps.

Incandescent filament black light sources

This type of source of black light comes in 75 and 150 watt sizes. It comes as standard incandescent bulb with a filter glass envelope. These sources give a considerable portion of visible light along with black light, as such are thus even less usable and suitable than the fluorescent black light sources.

4.5.2. Measurement of ultraviolet radiation intensity

As far back as 1942, selenium cell photoelectric meters were being used to measure black light intensity. The most common, easily used foot-candle meters made by Weston and General Electric were designed for use by illumination engineers. The foot-candle was used as a unit of visible light as seen by the human eye under photic conditions. There is no such thing as a foot-candle of black light. For convenience, black light was incorrectly measured in foot-candles for many years, with an unfiltered Weston 703 foot-candle meter. Even though these readings did not make sense, they did give reproducible numbers. Further, no other meter capable of true measurements in the near-ultraviolet wavelength range was then available.

Measurement of black light intensity requires the use of a special meter calibrated in watts per square metre or microwatt per square centimetre. The meter J-221 is shown in Figure 4.20. This meter is filtered so that it responds only to black light. It is also filtered so as not to read short wave ultraviolet. The meter scale runs up to 5000 $\mu\text{watt}/\text{cm}^2$, which is expandable up to 25000 $\mu\text{watt}/\text{cm}^2$ by attaching a multiplier screen supplied with the meter.

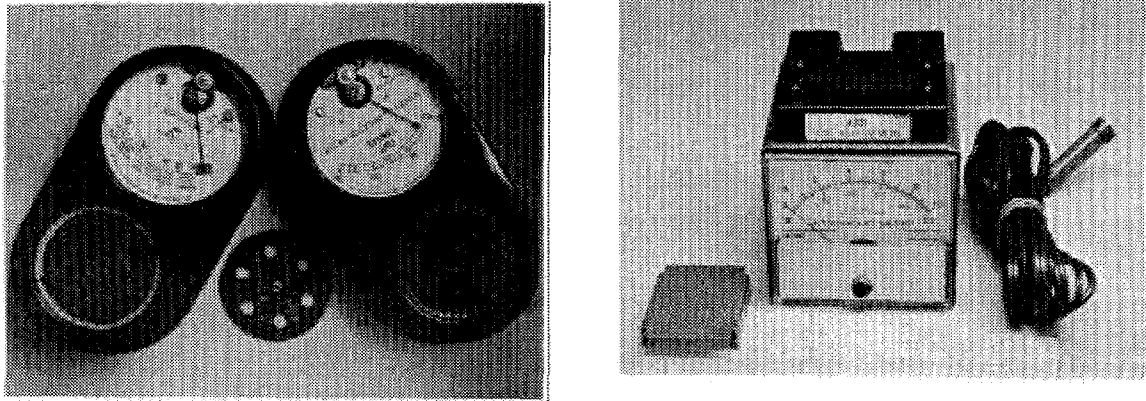

Figure 4.20: Photoelectric instruments used to measure black light intensity.

4.5.3. Checking the efficiency of ultraviolet lamps

An integral part of the fluorescent penetrant system is the ultraviolet light source (black light), the intensity of which is vital to a reliable result. It is recommended that this intensity be checked weekly or more often if the light is being operated at an intensity level close to the minimum. The instrument commonly used for measurement of black light intensities is the Ultra Violet Products Model J-221 Black-Ray Ultraviolet Intensity Meter. Measurements are taken at distances of 38 cm (15 inch) from the face of the filter on the black light, in the centre of the ultraviolet light beam. Various specifications call for minimum black light intensities of 8.6 to 10.2 W/m^2 (865 or 1020 mW/cm^2) when using the Black Ray J-221 Meter.

Once having established a level of illumination necessary for a particular job, it is important to observe precautions to ensure that this level is maintained. Several things can cause reduction in light from a black light source. Experience and tests have shown that light output decreases gradually with age and use of black light source. A tremendous reduction in output can result from improperly maintained enclosures. Oil and dust if collected at filter glass and external reflector can reduce light intensity at the work surface by 50% or even more.

4.5.4. Cabinets for observation of fluorescent penetrating liquids

For best results, inspection for fluorescent indications should be done in darkened area. The darker the area of inspection, the more brilliant the indications appear. This is extremely important, particularly when inspection is being performed for very fine, crack-like defects which may have trapped only a small amount of penetrant. It is also desirable that the inspection table or darkened area should be free of random fluorescent materials. If penetrant has been spilled in the inspection area, on the table, or on the operator's hands, it will fluoresce brilliantly and is likely to distract the operator's attention from defects.

The visible light intensity in an inspection area has a dramatic effect on inspection performance and reliability. More visible light makes fluorescent indications harder to see, requiring higher black light intensity to permit detection of indications.

Black light booths do not have less than 10 to 20 lux (1 to 2 foot-candles) visible light intensities because black lights (with filters) have some visible light output, and because of the induced fluorescence from the test parts, the inspector's clothing and spills of fluorescent material within the inspection booths.

The intensity of black light at the inspection surface can be altered by adjusting the distance. A typical black light test to meet most specifications, when using a J-221 meter, calls for distance of 38 cm (15 inch) and a minimum intensity not less than 10 W/m².

A black light booth or cabinet is considered to be best if the ambient visible light present is up to 10 lux or 1 foot-candle.

4.6. Standardized work pieces for evaluating processes and qualifying procedures

4.6.1. Comparator test blocks

Of all the tools currently used to evaluate penetrants and to judge the continued serviceability of a penetrant inspection system, the quench-cracked aluminium comparator block is the most popular. The cracked aluminium test block is described in both the ASME Code Section V and in the U.S. MIL-I-25135 specifications.

Article 6 on Liquid Penetrant Examination of Section V of the American Society of Mechanical Engineers ASME Boiler and Pressure Vessel Code contains a specification for fabricating cracked aluminium comparator blocks as already described in section 4.1.4.

Procedures for producing cracked aluminium comparator blocks

Several procedures have been evaluated for producing 8 by 50 by 75 mm (5/16 by 2 by 3 in.) 2024-T3 aluminium cracked standard panels. The first procedure, described in MIL-I-25135, involved heating with a torch to 510°C (950°F) for 4 min and quenching the panels in cold water. The torch was adjusted to heat the top centre of the specimen. Each specimen was heated and quenched from five to ten times successively to produce varied crack patterns. These panels had a grain direction parallel to the 75 mm (3 in.) dimension. A second procedure used to produce 10 by 75 by 100 mm (3/8 by 3 by 4 in.) 2024-T3 aluminium panels involved heating in a furnace to 540°C (1000°F) for 30 min and quenching in ice water. These specimens were quenched individually and checked after each quench in order to obtain an acceptable crack pattern with a minimum number of severe cracks extending through the specimens. The specimens that did not show an adequate crack pattern after twelve cycles of heating and quenching were then heated with a torch and quenched in the same manner as the 50 by 75 mm (2 by 3 in.) specimens until an acceptable crack pattern was obtained. These panels, which were cut from bar stock, represented an end grain condition (the grain direction was parallel to the 10 mm, or 3/8 in. thickness dimension).

The use of the Aluminium cracked block produced can then be made by following standard procedures as specified in specifications such as ASME Code, article 6.

Cracked chromium-plated test panels

The cracked chromium-plated reference panel provides a surface containing cracks of known dimensions and these flaws fall within a range of magnitudes close to the limit of the ability of test penetrants to reveal them. The chromium-plated test panels are useful for evaluation

of a penetrant system's flaw detection performance. They can provide useful results in qualitative side-by-side comparisons of penetrant performance. This type of panel is made by burnishing a brass or copper panel to a mirror finish, then electroplating a thin layer of nickel followed by a layer of chrome upon this polished surface. The chrome layer is brittle, and cracks can be generated in it by bending the panel over a curved form. Crack depth is controlled by the thickness of the layer of chrome plating, but there is no control over crack width. Crack depth may range from 1 or 2 to nearly 50 μm . Crack width is determined by the degree of deformation of the panel during bending and straightening. The width varies from a fraction of a micrometer (for thin chrome layers) to up to about 2 μm for chrome layers having a thickness in the range of 50 μm .

Variations in the composition of the plating baths and plating techniques determine the type and size of cracking in the nickel chrome test panels. Particulars on the preparation of three different crack size panels were published in MIL-I-8963.

- (a) Coarse crack panel with cracks measuring about 10 μm in width and 50 μm in depth.
- (b) Medium crack panel with cracks about 2 to 3 μm in width and 40 μm in depth.
- (c) Fine crack panel with cracks about 0.5 μm in width and 2 μm in depth.

Application of nickel-chrome test panels in evaluating penetrant system

Since the nickel-chrome sensitivity panel can be used over and over again, it is possible to compare one penetrant system to another sequentially by first testing one system and accurately recording results and then, after cleaning and drying, testing the second system.

A simultaneous comparison test of two different penetrant systems can also be made by dividing the chrome panel into two equal sections by means of a longitudinal wax line or narrow vinyl tape. One penetrant is applied to one half and a second on the other half of the panel. Using this technique, it is possible to obtain a side-by-side comparison of two penetrants or process materials. However, evaluation of variations in processing times and techniques is not so feasible. Penetrant systems should be compared not only as to the completeness of the flaw patterns but as to brightness and legibility of indications on the cracked chrome test panels.

Care and handling of nickel-chrome test panels

Do not bend the nickel-chrome panels. Flexing or bending will increase the size of the existing cracks and may create new cracks. Post-cleaning is important after each test. A suggested procedure for cleaning the panels between tests is as follows:

- (1) Scrub the panels with a soft cloth saturated with a mild liquid detergent solution. A typical hydrophilic emulsifier would be a suitable detergent. Then rinse the panels thoroughly with a water spray. This removes developer and some of the penetrant.
- (2) Immerse the panels in acetone for several minutes with some agitation. This removes crack-entrapped penetrant. Replace the acetone at frequent intervals.
- (3) Dry the panel.

If cleaning does not seem complete, repeat steps 2 and 3.

4.6.2. *Non-standardized test pieces for checking penetrability*

Penetrants have been shown to enter cracks or spaces as small as 5 micro-inches (127 nm) or even smaller. How fine a crack can a penetrant enter? If one can produce a very fine crack of given size or a graduated series of cracks, one might find the limit of penetrability. In Figure 4.21 the glass plate experiment aimed at producing cracks of known width is shown.

To produce cracks of known width, two pieces of heavy plate glass are clamped together. Each plate is 10 inches (254 mm) long by 1.5 inches (38 mm) wide by 3/8 inch (9.5 mm) thick, and is transparent. The extent of penetration can thus be determined by observation through the glass. When clamps are sufficiently tight and specimens are viewed under sodium light (5986Å) dark areas indicating plate contact appear between the plates under and adjacent to the clamps. Interference fringes extend outward from these areas making a convenient measure of the small opening between the plates. The distance between any two consecutive fringes represents a change in separation equal to one half the wave length of the light used to produce the fringes. Under sodium light, the separation at the last fringe before the black contact area would be 13 micro inches (330 nm). Fluorescent penetrant is swabbed onto the exposed edge of the interface between the glass plates, with the specimen in a horizontal position. The liquid penetrates the entire space between the plates up to the black contact area, where it feathers out. This demonstrates penetration into a space at least as narrow as 13 micro inches (330 nm) and is estimated at a minimum of 5 micro inches (127 nm). It has since been shown that modern "super bright" penetrants can be seen to a point well within this last interference ring.

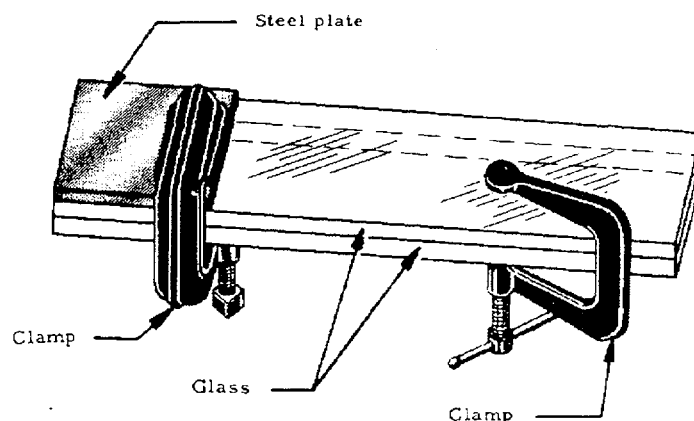

Figure 4.21: *Glass plate experiment.*

4.6.3. *Equipment for checking fluorescence efficiency of UV lamps*

Determination of fluorescent brightness can be done experimentally to evaluate the performance of fluorescent penetrant. A brief description of methods and related equipment is described as under:

(a) Laboratory fluorometers

These instruments normally contain the photometer sample holder and ultraviolet light source all in one package. They are normally designed to measure test tubes full of fluorescent liquid. When fluorometers are used for penetrant brilliance measurements, they must be equipped with proper filters, primary and secondary. The primary filters to absorb visible light and at low passage of ultraviolet light and secondary which corrects the photo detector to the correct wave length response. Figure 4.22 illustrates a laboratory type fluorometer specified by MIL-I-25135.

(b) Spectrophotometer instruments for measuring fluorescence brilliance

The most accurate measurement of fluorescent penetrant colour and brightness requires spectro-photometer. Spectrophotometers are instruments that separate light into many narrow spectral bands for measurement. Spectrophotometers are, however, seldom used for measurement of brilliance of actual penetrant test indication because the light available in one colour band is very low in intensity. Only very expensive spectrometers have sensitivity high enough to measure such low light levels. Many spectrophotometers are not possibly arranged to measure only spectra of lights emitted by the penetrant sample, instead they also receive the black light incident upon the sample to excite it.

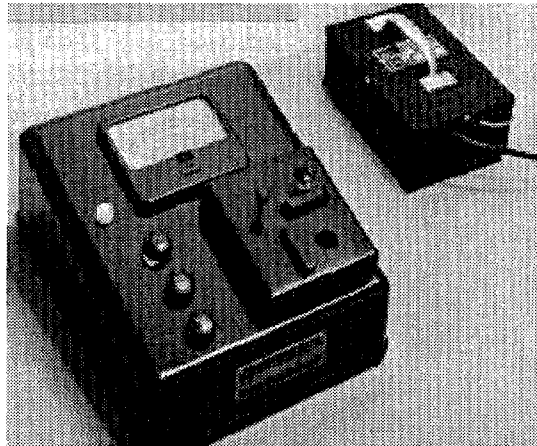

Figure 4.22: Laboratory-type fluorometer specified by MIL-I-25135 containing built-in black light source and interchangeable for light modification.

Because of difficulties encountered in the use of such spectrophotometers, use of filter photometer is made for determining the fluorescent brilliance of the penetrants. Filter photometers in general include a light-sensitive cell, a meter activated by the cell, and provisions for installation of light filters to exclude unwanted portions of the spectrum.

The meters used to measure the fluorescent brilliance of the penetrant materials should be filtered in such a way that the total response is as nearly equivalent as possible to the response of the normal eye.

5. CODES, STANDARDS, PROCEDURES AND SAFETY (PT)

5.1. Standards applicable to liquid penetrant testing

5.1.1. Test methods

British Standards Institution (BSI)

- (1) BS 4124. Penetrant flaw detection of steel forgings.
- (2) BS 4416. Methods for penetrant testing of welded or brazed joints in metals.
- (3) BS 6443. Method for detecting surface flaws in materials and components during manufacture and in service by penetrant flaw detection.
- (4) BS 3889. Methods for non-destructive testing of pipes and tubes. Part 3A describes penetrant testing of pipes and tubes.
- (5) BS 3683. Glossary of terms used in penetrant flaw detection. (Part 1)

American Society for Testing and Materials (ASTM)

- (1) ASTM A 462. Procedure for liquid penetrant inspection of steel forgings.
- (2) ASTM E 165. Standard recommended practice for liquid penetrant inspection method.
- (3) ASTM E 270. Definition of terms relating to liquid penetrant inspection.

Society of Automotive Engineers USA (SAE)

- (1) AMS 2645. Materials and equipment for fluorescent penetrant inspection.
- (2) AMS 2646. Materials and equipment for visible dye or colour contrast penetrants.
- (3) AMS 3155. Specifications for solvent soluble fluorescent penetrant.
- (4) AMS 3156. Specifications for water soluble fluorescent penetrant.
- (5) AMS 3157. Specifications for high fluorescent solvent soluble penetrant.
- (6) AMS 3158. Specifications for water based fluorescent penetrant intended for use in liquid oxygen (LOX) systems.

Department of Defence (DOD) USA

- (1) Mil 125135. Specification for visible and fluorescent penetrant materials.
- (2) Mil-1-25135. Penetrant products.
- (3) Mil-F-38762. Fluorescent penetrant inspection unit.

American Society of Mechanical Engineers (ASME)

- (1) SE 165. Standard practice for liquid penetrant inspection method.
- (2) Article 6. Liquid penetrant examination.

5.1.2. *Materials for the test*

MIL Specifications

When penetrant testing is used for US military or government material or application, penetrant materials must conform to specifications (usually cited in contracts and purchase orders). The specification MIL-J-25135 covers materials used in the penetrant inspection of metal, non porous ceramics and plastic parts to determine material defects open to the surface.

ASTM Specifications

ASTM code describes the method for the determination of contaminant in the penetrant materials such as D-129 test for sulphur in petroleum product, D-808 test for chlorine in new and used petroleum products and D-1193 specifications for reagent water.

British Standards Institution

The standard on inspection BS 6443 describes the requirements of materials. One of the essential requirements being their compatibility with the materials to be inspected and the ultimate use of the component. In the absence of a peculiar requirement, it is recommended that the residual halogen content of penetrant process materials should be limited to 1%.

5.1.3. *American Society of Mechanical Engineers (ASME) Code*

The American Society of Mechanical Engineers set up a committee in 1911 to formulate standard rules for the construction of steam boiler and other pressure vessels. This committee is now called the Boiler and Pressure Vessel Committee.

The committee's function is to establish rules of safety governing the design, fabrication and inspection during construction of boilers and unfired pressure vessels; and to interpret these rules when questions arise regarding their intent. The committee has published the ASME Boiler and Pressure Vessel Code (BPV code) as an American Standard. The first code was published in 1914 and revised and updated editions have been issued at regular intervals since. The ASME Boiler and Pressure Vessel Code contains the following sections:

Section I: Power boilers

This section includes rules and general requirements for all methods of construction for power, electric and miniature boilers and high temperature water boilers used in stationary service. This section also includes power boilers used in locomotives, portable and traction service.

Section II: Materials specifications

- Part A; Ferrous materials.
- Part B; Non ferrous materials.
- Part C; Welding rods, electrodes and filler metals.

This section is a service section to the other code sections providing material specifications adequate for safety in the field of pressure equipment.

Section III: Rules for construction of nuclear power components

This section provides requirements for the materials design, fabrication, examination, testing, inspection, installation, certification, stamping and overpressure protection of nuclear power plant items such as vessels, concrete reactor vessels and concrete containments, storage tanks, piping systems, pumps, valves, core support structures and component supports for use in, or containment of, portions of the nuclear power system of any power plant. This system contains the following two divisions:

Division I:

- Subsection NB Class 1 Components.
- Subsection NC Class 2 Components.
- Subsection ND Class 3 Components.
- Subsection NE Class MC Components.
- Subsection NG Core Support Structure.

Division II:

- Code for Concrete Reactor Vessels and Containments.

Section IV: Heating boilers

This section covers minimum safety requirements for designing, fabrication, installation and inspection of steam generating boilers, and hot water boilers intended for low pressure service that are directly fired by oil, gas, electricity or coal.

Section V: Non-destructive examination

This section contains requirements and methods for non-destructive examination which are referenced and required by other code sections. This section also includes manufacturer's examination responsibilities, duties of authorized inspectors and requirements for qualification of personnel, inspection, and examination. Examination methods included in this section are intended to detect surface and internal discontinuities in material, welds and fabricated parts and components.

Section VI: Recommended rules for care and operation of heating boilers

This section covers the latest specifications, terminology, and basic fundamentals applicable to steel and cast iron boilers limited to the operating ranges of section IV, Heating boilers. This section also includes guidelines for associated controls and automatic fuel burning equipment.

Section VII: Recommended rules for care of power boilers

In order to promote safety in the use of stationary, portable, and traction type heating boilers, this section provides rules to assist operators of power boilers in maintaining their plants as safe as possible.

Section VIII: Pressure vessels

This section is divided into two divisions. Division 1 covers the minimum safety requirements applicable to the construction, design, and fabrication of pressure vessels under either internal or external pressure for operation at pressure exceeding 15 psig and to vessels

having inside diameters exceeding six inches. Pressure vessels made according to the rules of Division 2 require closer inspection of the required fabrication details, material inspection, welding procedures and details, material inspection, welding procedures and welding and more non-destructive examination, as the safety factor used for these vessels is less than the safety factor used for vessels fabricated according to the rules of Division 1.

Section IX: Welding and brazing qualifications

This section covers rules relating to the qualification of welders, brazers, and welding and brazing operators in order that they may perform welding or brazing as required by other code sections in the manufacture of components.

Section X: Fibreglass-reinforced plastic (FRP) pressure vessels

This section covers minimum safety requirements for construction of FRP pressure vessels in conformance with a manufacturer's design report. The production, processing, quality control and inspection methods are prescribed to assure the quality of the vessel.

Section XI: Rules for in-service inspection of nuclear power plant component division 1

This section provides rules and requirements for in-service inspection of Class 1, 2 and 3 pressure retaining components and their supports, and in-service testing of pumps, valves and components in light-water cooled nuclear power plants. This division categorises the areas subject to inspection and defines responsibilities, provisions for accessibility, examination method and procedures, personnel qualifications, frequency of inspection, record keeping and reporting requirements, procedures for evaluation of inspection results and subsequent deposition of results of evaluation, and repair requirements. This division provides for the design, fabrication, installation and inspection of replacements.

General format of section V

Section V contains requirements and methods for NDE, detailed in 16 articles which become ASME code requirements when referenced by other sections. These methods are intended to detect surface and internal discontinuities in materials, welds and fabricated parts and components. Article 1 (Appendix B) serves as an introduction and covers general requirements such as manufacturers examination responsibility, duties of the authorized inspector, written procedures, inspection, examination and qualification of personnel. The balance of section V is organized in two sub-sections, A and B, Appendix A (glossary of terms), Appendix B (SI units) and an index. Subsection A (Articles 2 to 10) defines the specific NDE methods required by the ASME code. Subsection B (Articles 21 to 27) contains the basic standards, procedures and recommended practice documents of each of the NDE techniques as adopted from the American Society for Testing of Materials (ASTM).

5.2. Test specifications and procedures

Specifications means “mentioned particularly, set down as requisite, being specific etc.” Specification: A statement in relevant document of a set of requirements to be satisfied by a product, a material or process indicating the means by which it may be determined whether the requirements given are satisfied. In non-destructive testing, a procedure is an orderly sequence of rules that describes how a specific technique shall be applied.

5.2.1. Interpretation

The terms “interpretation” and “evaluation” refer to two entirely different steps in the testing process. To interpret an indication means to decide what type of discontinuity caused it. It may be a crack, porosity, lack of bond, or merely some surface anomaly. To evaluate an indication means to assess its potential effect on the usefulness of the article. The inspector is required to process each specimen, interpret indications, evaluate the seriousness of discontinuities, and determine the disposition of the specimen. He or she is normally provided with an acceptance standard which covers the type, size and spacing of discontinuities which are rejectable.

5.2.2. Formulation of instructions for the test

The successful use of liquid penetrant inspection method calls for the operator to follow a set of instructions as laid down in the written procedure. This procedure can be a general type or specific depending upon the nature of test. The procedure should however have at least the following details:

- (a) The materials, types, shapes, or sizes to be examined, and the extent of the examination;
- (b) Type (number or letter designation if available) of each penetrant, penetrant remover, emulsifier, and developer;
- (c) Processing details for pre-examination cleaning and drying, including the cleaning materials used and minimum time allowed for drying;
- (d) Processing details for applying the penetrant; the length of time that the penetrant will remain on the surface (dwell time) and the temperature of the surface and penetrant during the examination if outside 60°F to 125°F (16°C to 52°C) range;
- (e) Processing details for removing excess penetrant from the surface, and for drying the surface before applying the developer;
- (f) Processing details for applying the developer, and length of developing time before interpretation;
- (g) Processing details for post-examination cleaning.

General procedure of liquid penetrant inspection method (welds)

Description of the method

The liquid penetrant examination method is an effective means for detecting discontinuities which are open to the surface of non-porous metals and other materials. Typical discontinuities detectable by this method are cracks, seams, laps, cold shuts, lamination, and porosity.

In principle, a liquid penetrant is applied to the surface to be examined and allowed to enter discontinuities. All excess penetrant is then removed, the part dried, and a developer is applied. The developer functions both as a blotter to absorb penetrant that has been trapped in discontinuities, and as a contrasting background to enhance the visibility of penetrant indications. The dyes in penetrants are either colour contrast type (visible under white light), or fluorescent type (visible under ultraviolet light).

Scope

The procedure is adaptable for the three techniques:

- Water washable.
- Post-emulsifying.
- Solvent removable.

The use of either colour contrast technique or fluorescent technique will be made.

Fluorescent penetrant inspection will not be carried out after the colour contrast penetrant.

Surface preparation

- In general, satisfactory results are obtained when the surface of the part is in the as-welded, as-rolled, as-cast, or as-forged condition. Surface preparation by grinding, machining, or other methods may be necessary where surface irregularities could mask indications of unacceptable discontinuities. Blasting with shots or dull sand maypeen discontinuities at the surface and should not be used.
- Prior to all liquid penetrant examinations, the surface to be examined and all adjacent areas within at least 1 in. (25 mm) shall be dry and free of all dirt, grease, lint, scale, welding flux, weld spatter, oil, and other extraneous matter that could obscure surface openings or otherwise interfere with the examination.
- Typical cleaning agents which may be used are detergents, organic solvents, descaling solutions, and paint removers. Degreasing and ultrasonic cleaning methods may also be used.

Drying of test surface

After cleaning, drying of the surface to be examined may be accomplished by normal evaporation or with forced hot air, as appropriate. A minimum period of time should be established to ensure that the cleaning solution has evaporated prior to application of the penetrant.

Technique requirement

As a standard technique, the temperature of the penetrant and the surface of the part to be processed should, not be below 60°F (16°C) nor above 125°F (52°C) throughout the examination period. Local heating or cooling is permitted provided the part temperature remains in the range of 60°F to 125°F (16°C to 52°C) during the examination. Where it is not practical to comply with these temperature limitations the procedure should be established or qualified for such temperatures.

Application of penetrant

The penetrant may be applied by any suitable means such as dipping, brushing or spraying. The minimum penetration time shall be as given in Table 3.2.

Removal of excess penetrant

After the specified penetration time has elapsed, any penetrant remaining on the surface shall be removed, taking care to minimize removal of penetrant from discontinuities.

- **Water washable penetrants.** Excess water washable penetrant will be removed with a water spray. The water pressure shall not exceed 50 PSI (345 Pa), and the water temperature will not exceed 110°F (43°C).
- **Post-emulsifying penetrants.** With post-emulsifying penetrants, the emulsifier will be applied by spraying or dipping. Emulsification time is critical and governed by surface roughness and type of discontinuities sought. It will not exceed 5 minutes unless other times have been qualified by actual tests. After emulsification, the mixture may be removed by a water spray using the same process as for water washable penetrants.
- **Solvent removable penetrants.** Excess solvent-removable penetrants will be removed by wiping with a cloth or absorbent paper, repeating the operation until most traces of penetrant have been removed. The remaining traces shall be removed by lightly wiping the surface with cloth or absorbent paper moistened with solvent. To minimize the removal of penetrant from discontinuities, care will be taken to avoid the use of excess solvent. Flushing the surface with solvent, following the application of the penetrant and prior to developing, is prohibited.

Drying

For the water-washable or post-emulsifying technique, the surfaces may be dried by blotting with clean materials or by using circulating warm air, provided the temperature of the surface is not raised above 125°F (52°C).

For the solvent-removable technique, the surfaces may be dried by normal evaporation, blotting, wiping, or forced air.

Developing

The developer will be applied as soon as possible after penetrant removal, the time interval should not exceed that established in the procedure. Insufficient coating thickness may not draw the penetrant out of discontinuities, conversely, excessive coating thickness may mask indications.

With colour contrast penetrants, only a wet developer shall be used. With fluorescent penetrants, a wet or dry developer may be used.

- **Dry developer application.** Dry developer will be applied only to a dry surface by a soft brush, hand powder bulb, powder bulb, powder gun, or other means, provided the powder is dusted evenly over the entire surface being examined.
- **Wet developer application.** Prior to applying suspension type wet developer to the surface, the developer must be thoroughly agitated to ensure adequate dispersion of suspended particles.

(a) Aqueous developer application

Aqueous developer may be applied to either a wet or dry surface. It will be applied by dipping, brushing, spraying, or other means, provided a thin coating is obtained over the entire surface being examined. Drying time may be decreased by using warm air, provided the surface temperature of the part is not raised above 125°F (52°C). Blotting is not permitted.

(b) Non-aqueous developer application

Non-aqueous developer shall be applied only to a dry surface. It will be applied by spraying, except where safety or restricted access preclude it. Under such conditions, developer may be applied by brushing. Drying shall be by normal evaporation.

Interpretation

The true size and type of discontinuities are difficult to evaluate if the penetrant diffuses excessively into the developer. Consequently, the surface will be closely observed during the application of the developer to monitor the behaviour of indications which tend to bleed-out profusely. Final interpretation should be made after allowing the penetrant to bleed-out for 7 to 30 min. If bleed-out does not alter the examination results, longer periods are permitted. If the surface to be examined is large enough to preclude complete examination within the prescribed time, the surface will be examined in increments.

- **Colour contrast penetrants.** With a colour contrast penetrant, the developer forms a reasonably uniform white coating. Surface discontinuities are indicated by bleed-out of the penetrant which is normally a deep red colour that stains the developer. Indication with a light pink colour may indicate excessive background, making interpretation difficult. Adequate illumination is required to ensure adequate sensitivity during the examination and evaluation of indications.
- **Fluorescent penetrants.** With fluorescent penetrants, the process is essentially the same as above, except that the examination is conducted in a darkened area using filtered ultraviolet light, called black light. The black light intensity at the surface under examination shall be measured at least once every 8 hours, and whenever the work location is changed, using a metre which is sensitive to light in the ultraviolet spectrum, centred on 365 nano metre (nm) (3650 Å). Two readings shall be taken; the first without a filter and the second with an ultraviolet (365 nm) absorbing filter over the sensing element of the meter. The second reading shall be subtracted from the first and the difference shall be minimum of 800 $\mu\text{W}/\text{cm}^2$. The black light shall be filtered ultraviolet radiation of wave lengths within the range of 330 nm to 390 nm. The bulb shall be turned on and allowed to warm up for not less than 5 minutes prior to use in the examination.

Evaluation of indications

- All indications will be evaluated in terms of the acceptance standards of the referencing code section.
- Discontinuities at the surface will be indicated by bleed-out of penetrant, however, localized surface irregularities due to machining marks or other surface conditions, may produce false indications.
- Broad areas of fluorescence or pigmentation which could mask indications of discontinuities are unacceptable, and such areas will be cleaned and re-examined.

Qualification of techniques for non-standard temperatures

When it is not practicable to conduct a liquid penetrant examination within the temperature range of 60°F to 125°F (16°C to 52°C) the examination technique at the proposed temperature requires qualification. This will require the use of a quench cracked aluminium block, which is designated as a liquid penetrant comparator. One section of the block shall be examined at the proposed temperature, and the other section shall be examined at a temperature in the range of 60°F to 125°F (16°C to 52°C).

Report writing

The test indications observed will be recorded and reported as a report. The test report form should have all the necessary details on processing and processing materials used i.e. type, make etc.

5.3. National standards for liquid penetrant testing and testing personnel

Some of the organizations whose standards are commonly used in liquid penetrant testing internationally are:

- (1) ASME - American Society of Mechanical Engineers.
- (2) ASTM - American Society for Testing Materials.
- (3) IIW - International Institute of Welding.
- (4) ISO - International Organization for Standardization.
- (5) DIN - German Standardizing Body.
- (6) BSI - British Standards Institution.
- (7) JIS - Japanese Industrial Standards.
- (8) SAA - Standards Association of Australia.
- (9) SAE - Society of Automotive Engineers USA
- (10) DOD - Department of Defence USA
- (11) API - American Petroleum Institution.

Some of the well known international standards for qualification and certification of NDT personnel are the following:

- (12) Mil-STD-410 — Qualification of inspection personnel (Magnetic Particle and Liquid Penetrant).
- (13) ISO/DIS/9712 — Non Destructive Testing- Qualification and Certification of personnel.
- (14) BS EN 473-93 — General principles for qualification and certification of NDT personnel.
- (15) SNT-TC-1A — Recommended practice for Qualification and Certification of NDT personnel. This document was developed by the American Society for Non-destructive Testing (ASNT).

5.4. Quality control of the test and procedure for its administration

The quality control during the liquid penetrant testing method can be achieved through making tests for evaluating and controlling the penetrants, emulsifiers and developers. These tests are of the following four types and have different objectives.

a) Evaluation or performance tests

These tests are aimed at giving information as to the quality and probable performance in use of penetrants and related materials. For the most part, they are tests which compare such materials in various significant aspects with standards selected for their known and proved excellence over a period of actual use.

b) Tests for physical properties

The prime purpose of such tests is to establish conformity with certain physical parameters which may have been established for a certain type of material. As acceptance and control tests they indicate the uniformity of a penetrant or emulsifier, from batch to batch or shipment to shipment.

c) Operating control tests

These include tests for contaminants or other types of deterioration that would impair the effective performance of these materials, to determine that no significant deviation from optimum values has occurred.

d) Manufacturing control tests

These tests are of no interest to the users of the penetrant methods except that their use ensures uniformity in quality and performance from shipment to shipment.

5.4.1. Quality assurance requirements

The quality assurance programme has certain functions to perform which become requirements for any organization to incorporate them. Some of the important functions are:-

- (a) Establishment of quality standards.
- (b) Written procedures.
- (c) Control of document flow.
- (d) Maintaining identity and traceability of materials.
- (e) Calibration of equipment.
- (f) Retention of records.

5.5. Problems of industrial safety in the use of chemical and inflammable products

The safety considerations are to be realized and practised while making use of the chemicals and inflammable products at the time of precleaning and removal of excess penetrant. Vapour degreasing, solvent cleaning, acid and alkaline use are the few among the precleaning methods where special care should be exercised to combat the harmful effects of such chemicals. The specific possible problems associated with respective precleaning procedures are discussed in brief in the paragraphs to follow:

5.5.1. Personnel hazards and safety with vapour degreasing

Personnel using vapour degreasing systems should be aware of health hazards, including the possibility of excessive inhalation of chlorinated hydrocarbon vapours. These vapours adversely affect the mucous membranes of the respiratory system. Symptoms of excessive inhalation or absorption include headaches and fatigue. Long-term exposure may result in kidney and liver damage. High temperatures and high intensity ultraviolet light, such as produced by arc welding, can oxidize or decompose chlorinated hydrocarbon vapours to produce the highly toxic and dangerous gas phosgene (a poison gas once used in warfare). Other products of such decomposition include hydrochloric acid, carbon dioxide, and dichloroacetyl chloride, which aid corrosion and are strong irritants as well. Like other fluids used in penetrant testing, prolonged exposure of the skin to vapour degreasing solvents can extract oils from the skin, resulting in cracking of the skin and dermatitis.

5.5.2. Personnel hazards and safety with solvent cleaning

Personnel using solvent cleaning methods should be aware of the hazards of fire (with flammable solvents) and toxicity (with chlorinated hydrocarbon solvents, ketones, and alcohols), the flash points and permissible toxicity concentrations and should ensure operation in a well ventilated atmosphere.

5.5.3. Personnel hazards and safety precautions with acid cleaning

Personnel using acid cleaning techniques should be aware of the hazards associated with use of acids, particularly during hand wiping operations. Operators should be protected with face shields and rubber gloves, aprons, and boots. Nonslip floor coverings are recommended in areas used for hand wipe or acid spray cleaning. The work areas should be adequately ventilated to remove acid fumes and mists. Operators handling chemicals should wash their hands and faces before eating and before leaving the work areas at the end of a shift. If chemicals come into contact with the hands or body, immediate and thorough washing with cold water is required. If significant exposure has occurred, emergency treatment may be necessary. Eye fountains and showers are usually located adjacent to acid cleaning work areas for immediate use in case of accidents. Even dilute acids are dangerous and cause serious injuries if they contact the human eye. Immediate and thorough washing of the eyes at an eye fountain is vital in minimizing such injury. Mist from spray systems can contain all of the ingredients of the acid cleaners, and gassing can be a health hazard. Electrolytic acid cleaning systems can contribute to mist formation and are especially dangerous. Rubber shoes and gloves are recommended for operators working with electrolytic cleaning systems.

5.5.4. Personnel hazards and safety precautions with salt bath descaling

Salt bath descaling equipment should be operated only by trained personnel fully aware of the hazards involved. Flushed salts at 370 to 540°C (700 to 1000°F) are dangerous and produce severe burns and attack if splashed onto the human body. Eyes must be fully protected from the caustic. Test objects must be totally free of water when immersed in a salt bath, since the molten caustic will react violently and spatter when contacted with water. The highly reactive metal sodium is used in the sodium hydride cleaning process. Extreme caution is required to prevent water from coming into contact with sodium. Sodium fires are very intense and the operator should never use water, acid soda pyrene or carbon dioxide fire extinguishers on sodium fires. Instead, sand or earth, or special proprietary products only should be used to extinguish sodium fires.

5.5.5. *Applicable safety standards*

The organic base solvents used as cleaning of test parts and removal of excess penetrant are hazardous for their flammability and toxic effects. The organizations such as US Department of Health Education and Welfare, National Institute for Occupational Safety and Health (NIOSH) have laid down the flash points and toxicity values as standards of common cleaning solvents for safe use during inspection by liquid penetrant testing method.

TABLE 5.1: FLASH POINTS AND RELATIVE TOXICITY VALUES OF COMMON CLEANING SOLVENTS

Solvent	Flash Point		1977 Federal Standard	1977 Federal Standard
	°C	°F	ppm	mg/m ³
ALIPHATIC PETROLEUMS				
Kerosene	65	145		
Mineral Spirits	15	57		
Naphtha, Hi-Flash	45	110		
Naphtha, VM and P	10	48	500	2000
Stoddard Solvent	40	105	500	
CHLORINATED HYDROCARBONS				
Chloroform	None	None	50	240
Methylene Chloride	None	None	500	1740
Perchloroethylene	None	None	100	670
1, 1, 1, Trichloroethane	None	None	350	1900
Trichloroethylene	None	None	100	535
Trichlorotrifluoroethane	None	None		
ALCOHOLS				
Ethanol SD (denatured)	14	57	10000	1900
Isopropanol	12	50	400	980
Methanol	12	54	200	260
OTHER SOLVENTS				
Acetone	18	64	100	2400
Benzol (benzene)	11	12	1 ppm/8 h day	
Cellusolve (2-ethoxyethanol)	44	104	200	740
Toluol (toluene)	8	40	200	740

5.5.6. *Safety conditions required for the use of UV light*

When an operator is making use of black light source for inspection purposes, he should be sure of the following.

- (a) The filter glass is in place and is not cracked or damaged such that white light is emitted.
- (b) Gloves and the otherwise necessary safety clothing may be worn.
- (c) After prolonged running of the lamp, housing gets very hot and can cause burning. Do not touch this lamp housing with unprotected flesh.
- (d) Do not, under any circumstances, shine the ultraviolet light onto the eyes.

- (e) Direct viewing of the lamp may, with certain people, cause an irritation of the eyes known as fluorescence of the retina. This is a temporary condition and can be overcome by wearing sodium glasses.
- (f) When using kerosene based inks with the hood in place, always have the ventilation fan operating.

5.5.7. Drafting of safety instructions for the personnel involved

The operators involved in the inspection work by penetrant method should be aware of necessary safety aspects of the chemicals and penetrant materials. The brief instructions worth bearing in mind are outlined as under:

Operators should not expose hands or skin to solvents since they dissolve skin oils and can lead to dermatitis or cracking of skin. Protective gloves and ointments to restore skin oil should be used, when operators must be in contact with solvents.

Areas used for solvent cleaning should have adequate ventilation to remove fumes and prevent accumulation of vapours in explosive or toxic concentrations. This is very important as vapours of chlorinated hydrocarbons can have potentially lethal anaesthetic actions when they are inhaled.

Smoking should be prohibited in all areas used for precleaning by vapour degreasing or solvents.

Disposal of sludge residues from cleaning operations must follow federal, state and local regulations. The sludge residue is toxic and may be flammable since it contains oil and grease collected during the degreasing operations. Direct contact with hot residue is dangerous. Sludge residues should be disposed of in covered containers which should not be airtight.

When making use of acids and alkali for descaling purposes, the operator should follow the normal precautions as are recommended. Few of the precautions are outlined as under:

- Always add acid to water, never add water to concentrated acid.
- When preparing new solutions, add acid to cold water and do not heat the solution until all the acid has been added.
- Test objects should be immersed or withdrawn slowly from acid cleaning solutions to avoid splashing acid.
- After acid cleaning, all test objects should be rinsed in water to remove all traces of residual acid.
- Before discarding used or spent acid cleaning solutions, the solutions should be neutralized or pumped into safe receptacles to be processed for later disposal. Federal, state, and local regulations should be observed when disposing of acid chemicals, even after neutralization for alkaline solutions.
- Alkalies should be added to water slowly using a hopper or a shovel, to obtain an even distribution of the chemicals in the solution.
- Adequate agitation should be provided after an alkali has been added to ensure that the chemicals dissolve.
- Temperature of the solution should not exceed 65°C (150°F) when alkaline chemicals are added. This precaution is to prevent eruption of the solution.

When making use of black light sources, the operator should follow the safety precautions as already discussed above.

5.5.8. Safety factors applicable to the test

The following safety requirements are not uniformly held throughout the world. These requirements are based on north American and European Union regulations. Each individual country, city or municipal authority should be contacted to ensure compliance with their own specific safety practices.

This information is not intended to cause an alarm with regard to these long-established materials. Rather, it is to alert users to the need for a safer working environment. Adequate skin and eye protection, together with good ventilation, will make for a healthy working environment.

5.5.9. Problems of industrial safety in the use of chemical and inflammable products

Surface examinations are performed in locations or use a type of material that could cause safety problems and so make precautions necessary. The easiest way to get information about the testing materials is to ask the manufacture of the testing materials.

Labels

The labels on the packages of the testing materials, for example, aerosols, tanks, barrels, etc. are an important source of information for the tester, on the label, we read:

- The name of the product.
- The batch number and/or the date of expiration.
- Application data.

The labels must have a minimum size, depending on the volume of the packaging.

Hazard symbol

If a hazard symbol must be affixed, it must not be smaller than 10% of the size of the signification label.

Name of the compounds

The name of the compounds of a product must be given, if according to the different signification rules, a hazard symbol (i.e. flammable irritant etc.) must be printed on the label).

Technical information for the testing system

The manufacturer must give the user a technical description of his testing system, which must contain:

- Description of each working step.
- Handling tips for the testing materials.
- Information about possible dangers which can occur during the application of the testing materials.
- Storage conditions and date of expiration.

Safety data sheets

The user must get a safety data sheet according to the national/local requirements, which must be written correctly, be complete and updated.

Hazard instructions

The user should be introduced to the possible hazards of the testing materials by manufacturer/supplier. He should get the following information:

- Handling of the testing materials.
- Safety clothes.
- Disposal of the testing materials.

Storage of the testing materials

The testing materials must be stored according to the newest transport and storage orders. In addition to the storage conditions and the storage duration on the label or the package, the date of expiration is also given. Some manufacturers also give information about the range of the storage temperature and advise that testing materials must not be kept near acids and alkalis, the storage places must be kept specifically for PT and MT materials and must adhere to local regulations

Introduction of the personnel

Employers are obligated to instruct their personnel according to the degree for hazardous substances.

Duties of the person responsible for testing

The level 2 or 3 qualified person who is responsible for the testing is obligated to instruct his co-workers about handling the testing materials. He must also ensure that his co-workers have thorough knowledge of the safety orders of the testing materials. Written notation must be made of the date at which this safety training is given. Personnel must be reintroduced to the safety requirements at regular intervals.

Organizing safety measurements for working in confined spaces

Closed rooms or areas could be tanks, pressure vessels, small rooms, pipes, etc. Because of the number of sources of danger in such areas, several safety orders must be followed closely. The person in charge is also obligated to take the following measures.

- Appointing a supervisor.
- Choosing and training co-workers.
- Ascertaining the given hazards.
- Choosing working procedures, working tools and working areas.
- Following the safety measures required by special personnel.
- Issuing working instructions.

Working with the safety technician

In each area, there is a safety technician who is responsible for safety in the areas where testing materials are being used or stored. The persons responsible for no-destructive testing should have close contact with these safety technicians.

Permanent supervision of the work area

The work area must be supervised in accordance with the required safety regulations, to avoid accidents and must be carefully controlled.

Choice of testing materials according to environment protection and workplace safety regulations

The choice of testing materials is governed not only by technical and other specific regulations but also by:

- The safety data sheets.
- The work area.
- The number of test pieces.
- The expected usage of the testing materials.
- The disposal possibilities (special waste disposal firms, office for water economy).

Safety standards for hazardous substances

This new order with regard to hazardous working materials is to ensure the protection of workers and end-users from the hazards generated by chemicals.

The new health and safety regulations must be observed at:

- The manufacture.
- The warehouse.
- The application.

It is also valid for the inspection materials

The R and S phrases

The risk (R) phrase should make sure that the characteristic hazards are clearly exposed. The safety (S) phrase is chosen for hazardous substances and preparations.

Occupational exposure limits (maximum allowable concentrations) are a guide for the user working with liquids which evaporate quickly or are toxic.

Marking

According to many authorities, hazard marking must appear on the labels of containers, bottles etc. and on the packages (see also the paragraph on labels). The markings must consist of the hazard symbol (e.g. skull and crossbones), hazard information (e.g. toxic), and the hazard identification letter (in our example T). They must be black with orange-red background. The letter chosen depends on the greatest percentage of hazardous substance present, the substances themselves and the size of the barrels.

Law for water disposal

The several laws for water disposal describe the new minimal requirements for direct waste-water introduction into creeks and rivers and indirect waste-water introduction into creeks and rivers and indirect waste-water introduction into sewage systems.

Accident prevention orders

For each workplace, Accident Prevention Orders (APOs) can be ordered at the trade inspection offices. When penetrant testing is being carried out in confined areas, it is vital to adhere to safety rules and regulations. These include:

- Hollow spaces in machines.
- Rooms without windows.
- Boilers.
- Tunnels and pipes.
- Tanks.
- Mines and pits.
- Box carriers.

Confined areas can be defined as work areas which are surrounded almost or totally with solid walls and where the substances, preparations or installations in them cause or can cause special hazards because of the type of work area. Special note is made of the increased hazards from gases and electricity.

Working under conditions where gas may cause increased danger

Gases cause increased danger when:

- The room has a small volume (<100 cubic meters) or;
- One or more dimensions (length, width, height) is <2 meters;
- Only a small natural air -change occurs.

The main protection measure against unhealthy, toxic or combustible gases is good ventilation of the room. If this isn't possible, breathing apparatus must be worn and explosion - proof tools or instruments used. Working overalls must be difficult to ignite and free from oil and fat.

Safety clothing

Safety clothing must be worn in the work area where penetrant testing is being conducted, just as they are anywhere products are being sprayed or chemicals handled. This avoids the penetrant material coming into contact with any part of the body. Most of the chemical testing materials remove the natural oils from the skin or have other negative medical effects, such as anaesthetic vapours.

- Face protection: Safety goggles or face shield.
- Hand protection: Gloves, skin-protection cream.
- Body protection: Work over-all and /or apron.
- Foot protection: Safety shoes.

If chemical contact occurs with eyes or skin, the instructions of the manufacturer must be followed. If no such instructions are available, the follow procedure should be followed:

Chemical contact with the skin:

- Remove the clothes.
- Wash with soap and plenty of water.
- Dry the skin.
- Rub in skin protection cream.
- Get medical attention if there is a problem.

Contact with the eyes:

- Wash off with soap and plenty of water.
- Get medical attention immediately.

6. PHYSICAL PRINCIPLES AND FUNDAMENTALS OF MAGNETIC PARTICLES (MT)

6.1. Electricity

6.1.1. Current

In accordance with the electron theory, an electric current is defined as an orderly movement of electrons from one part of a circuit to another. To obtain this movement in a simple electric circuit, it is necessary to have a source of electrical pressure (cell or generator) and a complete external electric circuit comprising a system of conductors connected to the source. In such a circuit, the conventional flow is from the positive terminal to the negative terminal. The actual movement of the electrons is from the negative terminal, where there is an excess of electrons, to the positive terminal where there is deficit. Each electron, being a minute negative charge of electricity, is always attracted to a positive charge. Figure 6.1 shows a portion of a conductor within which there is an electric field of intensity E .

In a metallic conductor the entire current is due to the motion of the free charges and thus in a metallic conductor electrons move in the opposite direction to the conventional current. The value of this current is given by the relation:

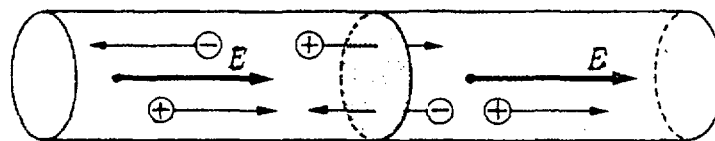

Figure 6.1: Negative charges crossing a section from right to left are equivalent to positive charges crossing from left to right.

$$I = \frac{Q}{t} \quad (1)$$

where Q is the net charge flowing across the section in time t . The value of current in MKS units is in amperes; one ampere represents a quantity of one coulomb of charge flowing per second.

6.1.2. Voltage

The charge has an associated potential energy because of its position. The electrical potential difference is defined in terms of potential energy per unit charge. The potential difference between two points, is the work that has to be done to move a unit positive charge between them. This work has to be done to move the charge against the electric force that is acting on it.

$$V = \text{Energy to move charge/charge moved} \quad (2)$$

The unit of potential difference is the 'volt' when the energy is in joules and the charge is in coulombs.

$$1 \text{ volt} = 1 \text{ Joule/coulomb} \quad (3)$$

If there is a potential difference of 10 volts between two points in an electrical circuit, this means that 10 J are needed to move 1C between them.

6.1.3. Resistance

Resistance is opposition offered by a conductor to the flow of current in a circuit, measured in Ohms. Resistance depends upon:

The length of the conductor.

- (a) The cross-sectional area.
- (b) The material of the conductor.
- (c) The temperature of the conductor.

The potential difference is proportional to the current, provided there is no change in the physical state of the conductor.

As, V is proportional to current I , this means:

$$V = R I \quad (4)$$

where R is a constant.

The constant R is known as resistance of the conductor. The relation (4) is known as Ohm's law. The unit of resistance is Ohm which is equal to a flow of current of one ampere through any conductor held at a potential difference of one volt. The value of resistance for a conductor depends upon the nature, dimensions and the physical state of the conductor. For a conductor of length L and area of cross section A , its resistance value is given as:

$$R = \rho L/A \quad (5)$$

where ρ is a constant known as resistivity and its value depends upon the nature of the material.

6.1.4. Alternating current

If we wish to maintain a continuous current in a conductor, we have to maintain a field, i.e. a potential difference, within it. If the field reverses its direction periodically the flow of charge reverses and the current is thus alternating between the two constant maximum positive and minimum negative values. The current changes its amplitude every half cycle as seen in Figure 6.2(b). In the curve, also recognized as sine wave, we see that the current attains the maximum positive value starting from zero in half of the cycle and an equal time is required to reach maximum of negative amplitude value.

6.1.5. Direct current

A direct current shall be flowing in any conductor if the applied field is always in the same direction even though it may fluctuate in magnitude, Figure 6.2(a). The lead storage batteries and other forms of cells are true sources of direct current. Use of rectifiers and filters helps in obtaining direct current from AC sources.

A device used to convert AC to DC is the rectifier which permits current to flow in one direction only. When a simple rectifier is applied to the AC current pattern in Fig 6.2(b) the result is the half wave pattern shown in Fig 6.2(c). With refinements, such rectifiers can be used to pass all the AC and then the pattern of Fig. 6.2(d) evolves.

AC is also available in three phase circuits. This provides three cycles that follow each other at interval of 60 degree. When these peaks are full-wave rectified, a very smooth DC is obtained (Fig. 6.2(e)).

Continuous direct current, alternating current and half wave direct current (HWDC) are used as magnetizing currents in magnetic particle testing. Each has its own advantages and limitations depending upon the particular application.

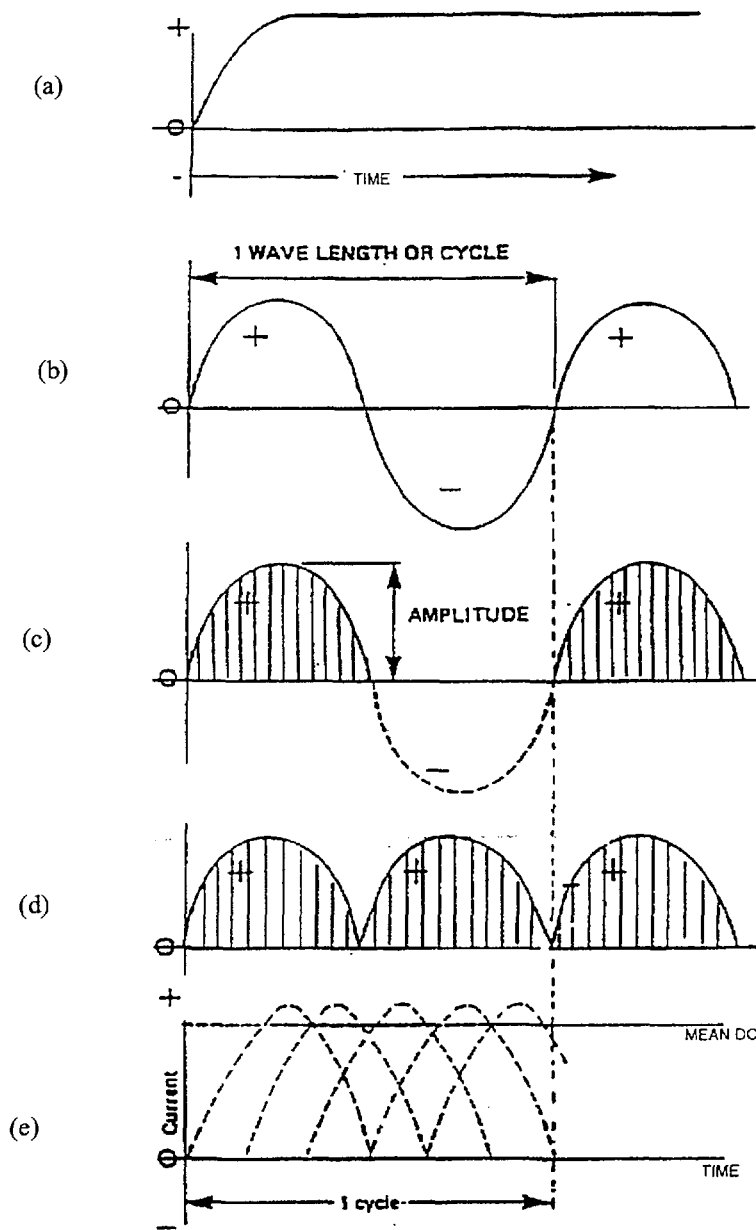

Figure 6.2: Alternating and direct currents.

6.2. Magnetism

The origin of the magnetism is due to the spin motion of the electrons. Each electron in an atom besides spinning around its nucleus also spins on an axis through it. The rotation and spin give rise to magnetic field. The net resultant of their currents or spins is to either cancel the net field or strengthen the resultant field. The atom thus behaves as a tiny magnet and is called a magnetic dipole. The magnetic fields of all such atoms are responsible for the magnetic behaviour of the substance made of these atoms.

A magnet is a material which has the following special properties:

- (1) It attracts other magnetic materials such as iron and some other metals.
- (2) The magnet has an associated field in its surrounding area.
- (3) The field lines originate from the north poles and enter into the magnet through south pole. However, within the magnetic material the field lines travel from south to north pole.
- (4) All magnets obey the basic rule of attraction and repulsion of other magnets by their respective poles, i.e. like poles repel and opposite poles attract each other.
- (5) A tiny magnet such as of compass needle will align itself parallel to earth's magnetic fields, i.e. in north south direction.

6.2.1. Magnetic poles

“Poles” are the points near each end of a magnet where the magnetism appears to be concentrated. The poles are distinguished by letters N (north seeking) and S (south seeking). The force of attraction or repulsion between like poles is given by Coulomb’s law:

$$F = \frac{m_1 \times m_2}{\mu r^2} \quad (6)$$

where m_1 and m_2 are strengths of two poles and r is the distance between them. μ is known as the permeability of the medium in which the poles are situated.

6.2.2. Permanent magnets

Permanent magnets are produced by heat treating specially formulated alloys in a strong magnetic field. During the heat treating process, the magnetic domains become aligned and remain aligned after removal of the external field. The magnetic materials suitable for permanent magnets require certain properties. Such materials are to be magnetically hard and have the following characteristics.

- (1) High remanence so that a high degree of magnetism is retained in the absence of a magnetic field.
- (2) High coercive field so that it is difficult to demagnetize the material.
- (3) A large area enclosed by the hysteresis loop, this being a consequence of it having a high remanence and high coercive force and this is a vital feature since high energy is then needed to demagnetize.

Commercial permanent magnets will last indefinitely if not subjected to high temperatures, to physical shock, or to a strong demagnetizing field. If the magnet becomes hot, however, the molecular structure can be rearranged, resulting in loss of magnetism that is not recovered after cooling. The point at which a magnetic material loses its ferromagnetic properties is the Curie temperature. For iron, this temperature is about 800°C, when the relative permeability drops to unity. A permanent magnet does not become exhausted with use, as its magnetic properties are determined by the structure of the internal atoms and molecules.

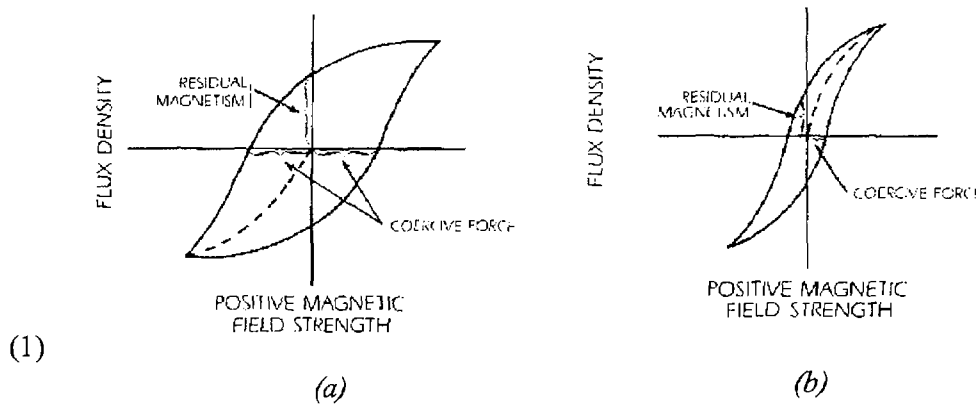

Figure 6.3: Hysteresis loops for typical ferromagnetic materials.

Common examples of permanent magnetic materials include alloys of aluminium, nickel and cobalt (alnico); copper, nickel and cobalt (cunico); copper, nickel and iron (cunife); and cobalt and molybdenum (comol).

6.2.3. Temporary magnets

Materials, such as mild steel which are easily magnetizable, lose part or whole of the magnetism on removal of the applied field. The magnetic domains which align themselves with the applied field are thus easily disturbed on the removal of the external field leaving the material partially magnetized Figure 6.4.

6.2.4. Ferro, para and dia magnetic materials

Materials can be grouped into three categories:

Ferromagnetic materials

Ferromagnetic materials are materials which have relative permeabilities considerably greater than 1. Ferromagnetic materials are metals. These materials become strongly magnetized in the same direction as the magnetizing field. The atoms in these solids have dipole moments, with the way in which the atoms bond together to form the solid resulting in the dipoles in neighbouring atoms aligning themselves all in the same direction Figure 6.5.

It is the coupling between atoms which results in their magnetic dipoles alignment that distinguishes ferromagnetic materials from paramagnetic materials where the dipoles are randomly orientated. Example of ferromagnetics are iron, cobalt, gadolinium and nickel.

Paramagnetic materials

These are materials which have relative permeability slightly greater than one. They are slightly magnetized but in the opposite direction of the applied magnetizing field.

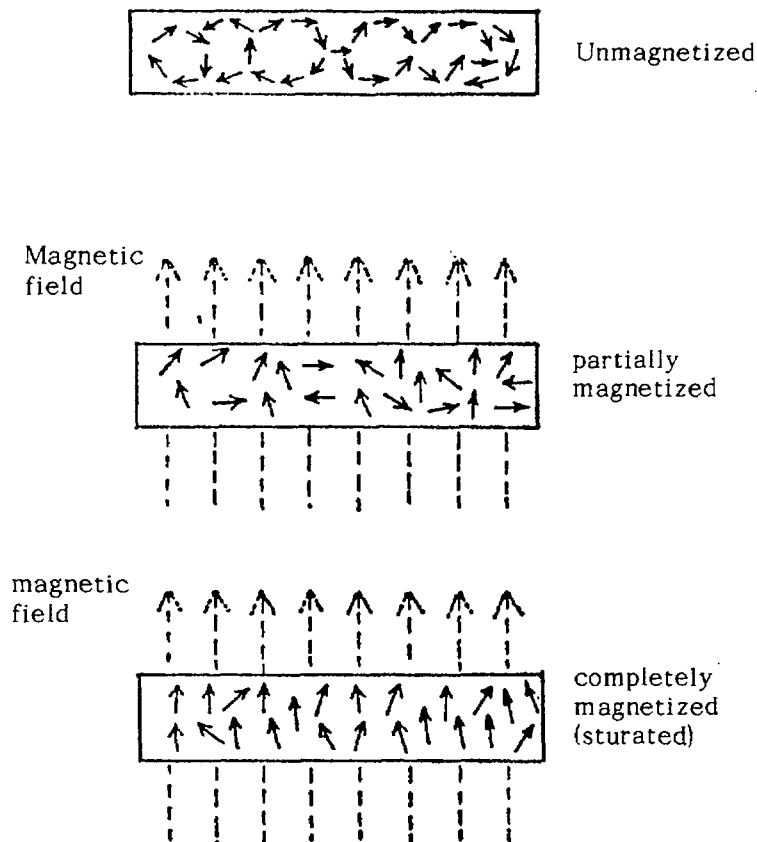

Figure 6.4: Alignment of domains when iron is magnetized.

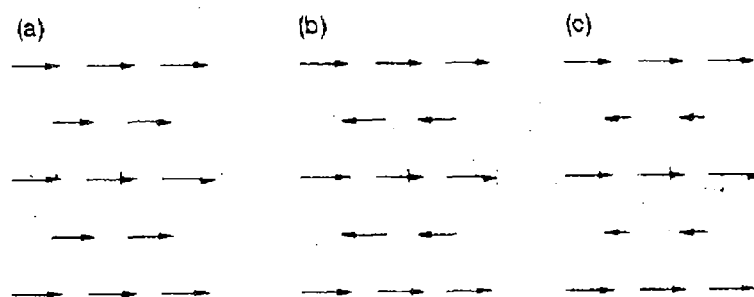

Figure 6.5: Dipole arrangements in (a) Ferromagnetics, (b) Antiferromagnetics, (c) Ferrimagnetics.

These have atoms or ions with a net dipole moment. The magnetic dipoles are, in the absence of an applied magnetic field, completely randomly orientated and thus the material shows no permanent magnetism. When a magnetic field is applied some small degree of alignment in the field direction can occur. The effect vanishes when the field is removed. The materials are

thus only weakly magnetic in the presence of the field. Aluminium, platinum, stainless steel, vacuum, air, wood, CuSO_4 and solid oxygen are examples of paramagnetic materials. Figure 6.6 (a & b) are B-H curves for paramagnetic and ferromagnetic materials.

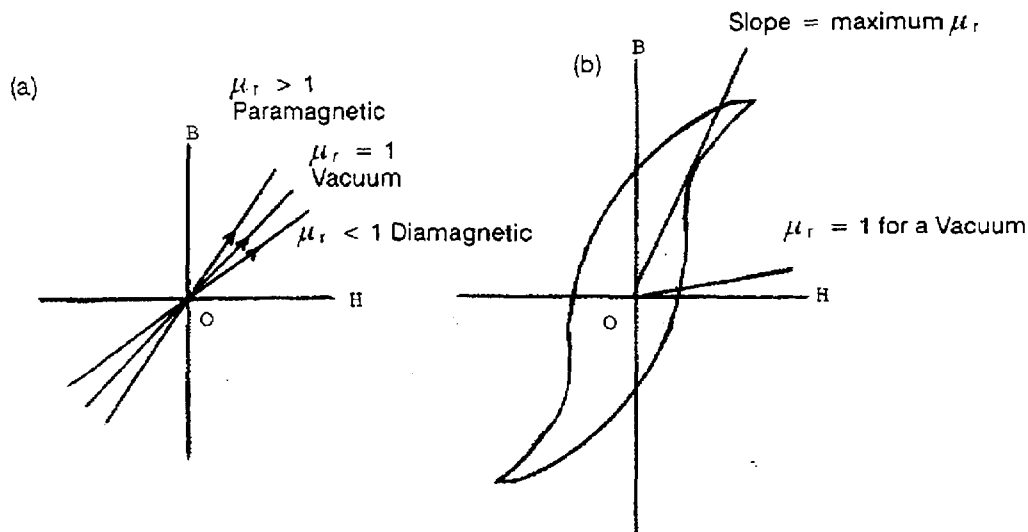

Figure 6.6: B-H graphs for (a) Paramagnetics and a vacuum, (b) Ferromagnetics.

Diamagnetic materials

Diamagnetic materials have a relative permeability less than 1 and the susceptibility is negative. They have atoms which do not have permanent dipole moments. We can consider the orbit of each electron about a nucleus to give rise to a dipole moment. However, the magnetic effects tend to cancel each other out and there is no net magnetic moment for atoms in a solid. When a magnetic field is applied electromagnetic induction can occur for each of the orbiting electrons since each can be considered as effectively a single turn coil carrying a current. The induced e.m.f. results in an induced current which is in such a direction as to oppose the change producing it. This means that the magnetic field produced by the induced current in the atomic coils is in the opposite direction to the magnetic field responsible for producing it. The result of applying the magnetic field to a diamagnetic material is thus to produce temporary dipole moments, these vanishing when the magnetic field is removed. Because these dipole moments oppose the field producing them they reduce the flux density to a value less than it would otherwise have had in a vacuum. Bismuth, Ag, Au, Pb, copper, mercury and water are examples of diamagnetic materials. All materials have diamagnetism since all can be considered to have orbiting electrons. But for diamagnetic materials there is no contribution to the magnetism from the spin of the electrons, while for paramagnetic and ferromagnetic. The magnetic dipole moments produced as a result of spin in such materials completely swamp the small diamagnetic effect.

6.2.5. Magnetic fields

Magnetic field is described as the area surrounding the magnetized material or magnet where the effects of the lines of force can be felt. The effect can be repulsive or attractive. The direction of the magnetic field is defined by the direction in which an isolated North pole (if it could exist of its own) would tend to move.

6.2.6. Leakage field

Sound material

The basic idea of magnetic particle inspection (MPI) is to locate and identify discontinuities in ferromagnetic materials. Let us examine how a magnetic field can assist us in doing this. Figure 6.7 represents a longitudinal cross section through a piece of magnetized material.

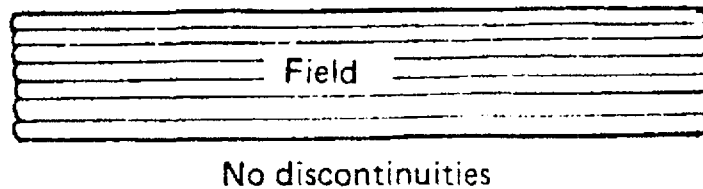

Figure 6.7.

In the absence of a crack or discontinuity, the lines of the magnetic field pass from one end of the object to the other without breaking through the surface.

Surface discontinuity

In the presence of a discontinuity Figure 6.8 some lines of the magnetic field may emerge from the object and pass through the air.

If very small ferromagnetic particles were sprinkled over the surface of the object shown in Figure 6.8 they would be attracted and held by the leakage field in the region of the discontinuity. Even though the discontinuity may be too small to be visible to the unaided eye, the magnetic field may still be disturbed enough to attract a sufficient number of fine particles to present a visible indication. These particles may be coloured to make them more visible and thus make the inspection method more sensitive. Even if the discontinuity is not open to the surface, Figure 6.9a, the field may be disturbed sufficiently to emerge from the object. Magnetic particles may then be attracted to the surface just above its location.

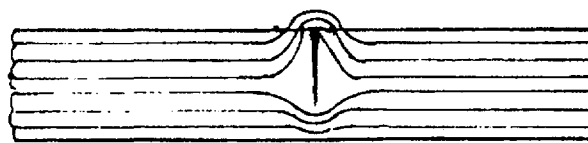

c) Surface Discontinuity

Figure 6.8.

Internal discontinuity

A discontinuity that lies deep within the object, however, may not disturb the lines of force sufficiently to cause them to emerge from the surface. In this case there would be no attraction of the particles and no surface indication Figure 6.9(b).

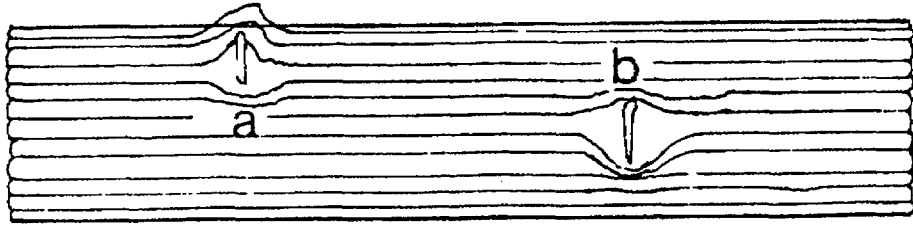

Figure 6.9.

In Figure 6.8 we saw the effect of a crack, and in Figure 6.9 the effect of a near surface discontinuity on the magnetic field. Since the permeability of air is much lower than that of the ferromagnetic materials, the lines of flux tend to pass through the air outside the bounds of material. This effect may be predicted mathematically by using the relationship

$$B = \mu.H \quad (7)$$

By decreasing μ and leaving H unchanged, the value of B will be smaller. This means a lower flux density will exist in air. The flux or field in air above the discontinuity is known as leakage flux or leakage field.

Orientation of discontinuities

A discontinuity oriented parallel to the magnetic field in the object will have far less effect on the field than a discontinuity perpendicular to the field.

Since the discontinuity at "b" in Figure 6.10 disrupts the magnetic field very little, there would be few if any magnetic particles attracted to it. Discontinuity "a" however causes considerable disruption of the magnetic field causing some lines of flux to leave the material. Magnetic particles would be more readily attracted to the surface near "a" marking the discontinuity more detectable.

The test sensitivity will then be best for discontinuities oriented 90° to the field direction, with tolerable results possible down to about 75° .

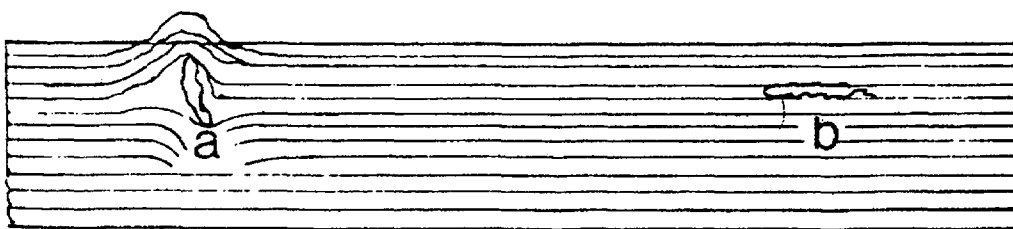

Figure 6.10.

6.3. Lines of force

The direction and intensity of a field surrounding a magnet can be shown by drawing imaginary 'lines of force' to indicate the path that an isolated N pole would take if it were free to move. How close together the lines are drawn depends on the field strength. Lines of field around a bar magnet and horse shoe magnet are as shown in Figure 6.11 and Figure 6.12.

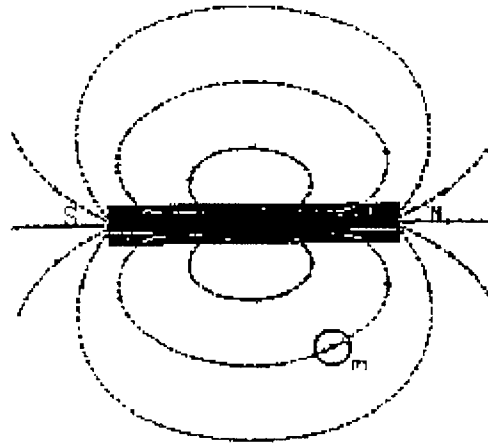

Figure 6.11: Lines of magnetic force of a bar magnet by means of a small compass needle.

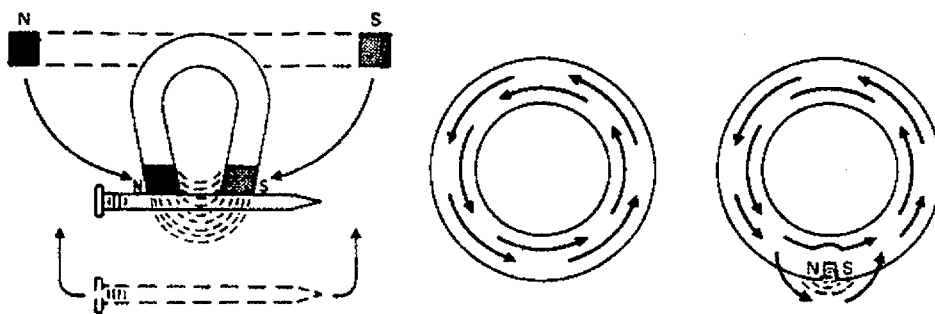

Figure 6.12: Magnetic lines of force of a horse shoe magnet.

Lines of force have the following properties:

- (1) They are in a state of longitudinal tension and tend to contract in length.
- (2) They take parallel paths and, acting in the same direction, tend to repel one another.
- (3) They never intersect.
- (4) They emerge from the North Pole and enter the south pole, forming a closed loop through the magnet.
- (5) Non- magnetic materials are transparent to lines of force.
- (6) They are deflected by and tend to pass through magnetic materials and in doing so they induce magnetism into that material.

6.4. Magnetic field around a conductor

It was noted by Danish physicist Hans Oersted that an electric current in a wire deflects a nearby compass needle. Since a magnetic needle is deflected only in a magnetic field, it can be easily concluded that a current in a wire produces a magnetic field around it. The field is circular and is stronger closer to the wire and becomes weaker as the distance from the wire increases.

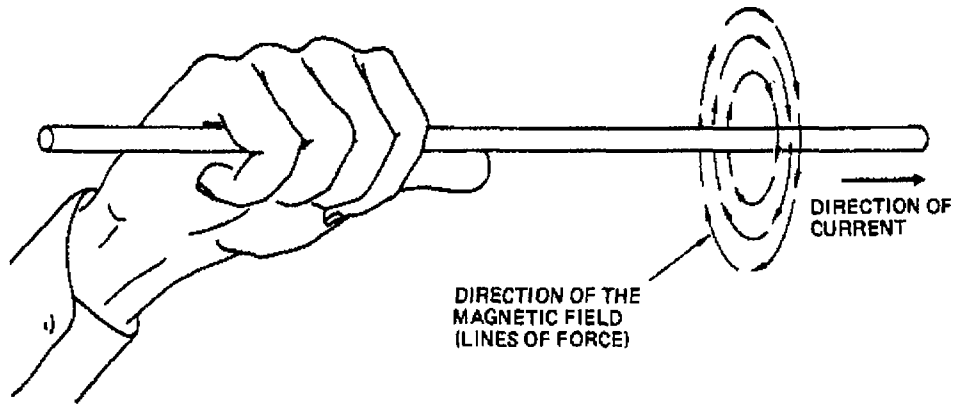

Figure 6.13: Illustration of the right hand rule.

The direction of the lines of force is given by right hand rule which states, "if the wire is grasped in the right hand with the thumb pointing in the direction of the current, the fingers of the hand will circle the wire in the direction of the magnetic field" Figure 6.13.

6.5. Field distribution in magnetic and nonmagnetic conductors

6.5.1. General

Either a solid or hollow central conductor is used in magnetic particles testing of hollow articles such as pipe, tubing, rings, flanges, nuts, etc. The magnetic field strength within and around a current carrying conductor varies with the type, size, and shape of the conductor, i.e. length, diameter, and material.

6.5.2. Solid nonmagnetic conductor

When current is passed directly through a solid, nonmagnetic conductor, such as a copper bar, the following observations hold true:

- (a) The magnetic field strength varies from zero at the centre to a maximum at the surface.
- (b) The field strength at the surface of the conductor decreases as the radius of the conductor increases; for example, if the current is held constant and the radius of the conductor is doubled, the field strength at the surface is halved. However, the larger conductor is capable of carrying more current.
- (c) When current is increased, the field strength increases in proportion, i.e., doubling the current doubles the field strength.
- (d) The field strength outside the conductor diminishes with the distance from the centre of the central conductor. For example, the field at two times the radius from the centre is half the field at the surface Figure 6.14.

6.5.3. Solid magnetic conductor

The strength of a field within a solid magnetic conductor, such as ferromagnetic steel, is much greater than in a solid nonmagnetic conductor because of the permeability of steel. The

field strength outside a solid magnetic conductor is exactly the same as with a non-magnetic conductor if the current and radius are unchanged Figure 6.15.

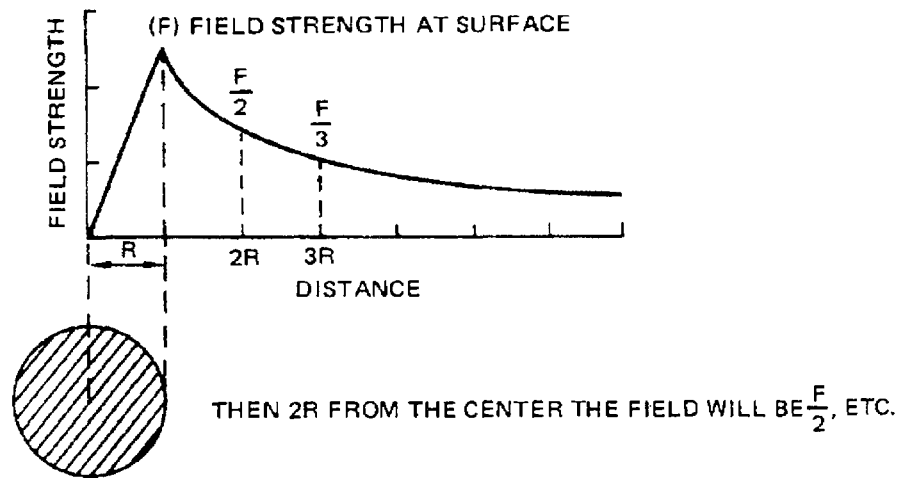

Figure 6.14: Field distribution in and around a solid nonmagnetic conductor.

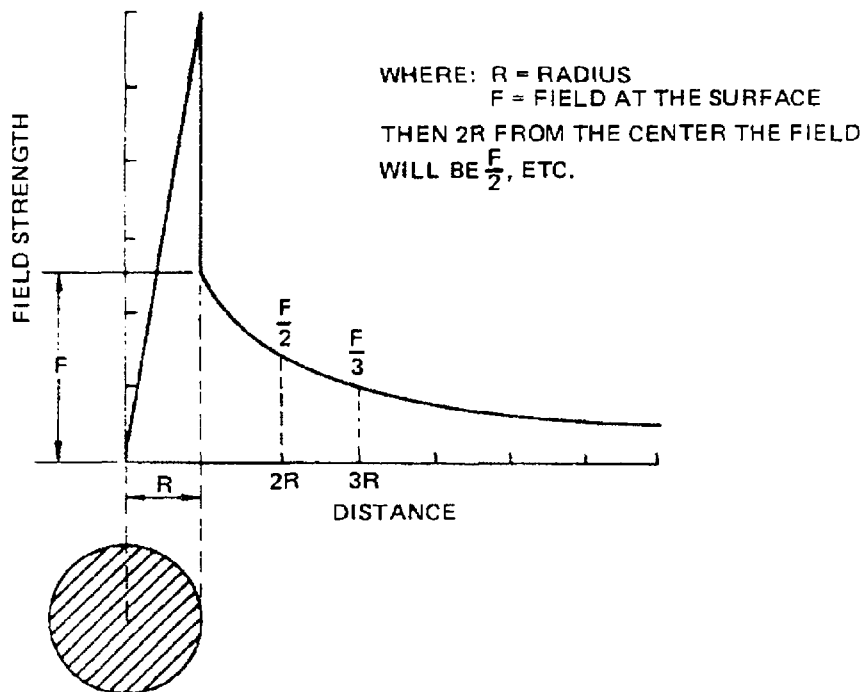

Figure 6.15: Field distribution in and around a solid magnetic conductor.

6.5.4. Hollow non-magnetic conductor

In a hollow, non-magnetic, circular conductor there is no current flow within the void. The field, zero at the centre of the void, increases to maximum at the outer surface. If a hollow non-magnetic and a solid non-magnetic conductor have the same outer diameter and the same

current flow, then the outer surface field strengths are equal. Figure 6.16 illustrates the field distribution in and around a hollow non-magnetic conductor.

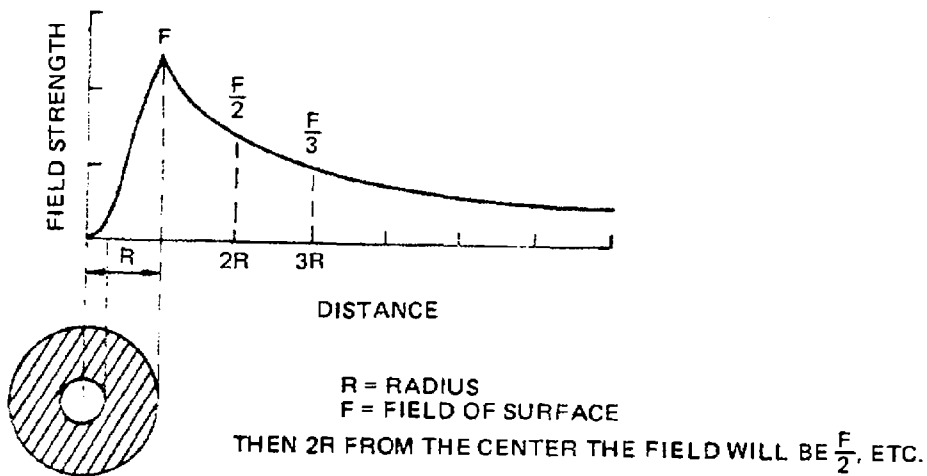

Figure 6.16: Field distribution in and around a hollow non-magnetic conductor.

6.5.5. Hollow magnetic conductor

When a hollow magnetic conductor is used, the permeability factor is again considered. Referring to Figure 6.17, the field strength at the outer surface of a hollow magnetic conductor is the same as that for the solid magnetic conductor, if their outer diameter and current flow are identical. The field strength at the inner surface is zero and the field outside the conductor is the same as for other conductors Figure 6.18.

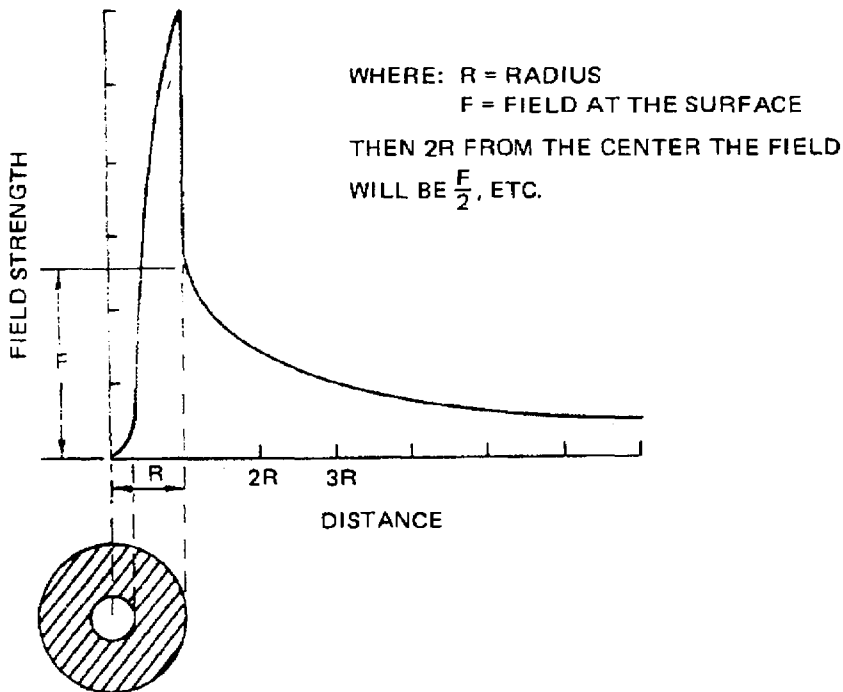

Figure 6.17: Field distribution in and around a hollow magnetic conductor.

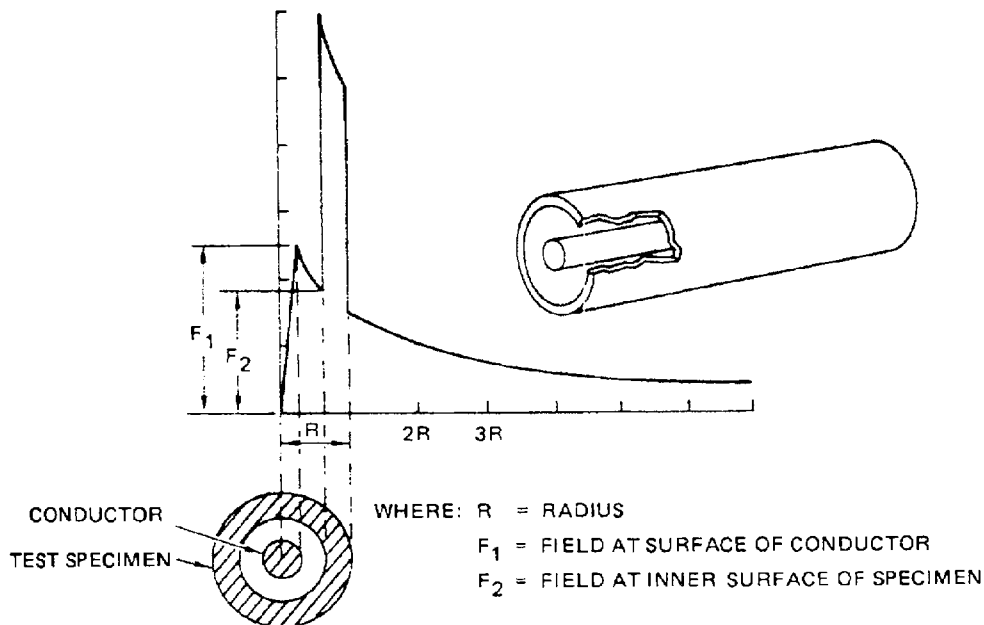

Figure 6.18: Field distribution in and around a hollow magnetic cylinder with central conductor.

6.5.6. Alternating current field distribution

In the foregoing discussion the use of direct current (DC) magnetization has been assumed; however, most of the rules concerning field distribution do not hold true when alternating current (AC) magnetization is used. Alternating current tends to flow near the surface of a conductor, even at commercial frequencies (50 cycles) this tendency is appreciable. This phenomena is known as "skin effect".

Solid magnetic conductor

In the case of a solid magnetic conductor carrying alternating current, the field distribution is similar to that shown in Figure 6.19. The field strength outside the conductor at any instant decreases in exactly the same way as when direct current is used as the magnetizing force. It must be remembered however, that while alternating current is flowing, the field is constantly varying both in strength and direction.

Hollow magnetic conductor

Similar differences in field distribution also occur with a hollow magnetic conductor, when alternating current is used for magnetization. This is shown in Figure 6.20.

6.5.7. Direct current residual fields

Residual circular fields remaining in magnetic conductors after DC magnetizing current is removed will be distributed in much the same pattern as when the current was flowing. When the DC is reduced to zero, the field will have less intensity, will conform to the distribution pattern shown in Figure 6.15 and, there will be substantially no field external to the conductor. When longitudinal magnetization is used, interruption of the magnetizing DC results in transient

currents being induced inside the specimen. These transient currents may slightly modify the strength and direction of the residual field.

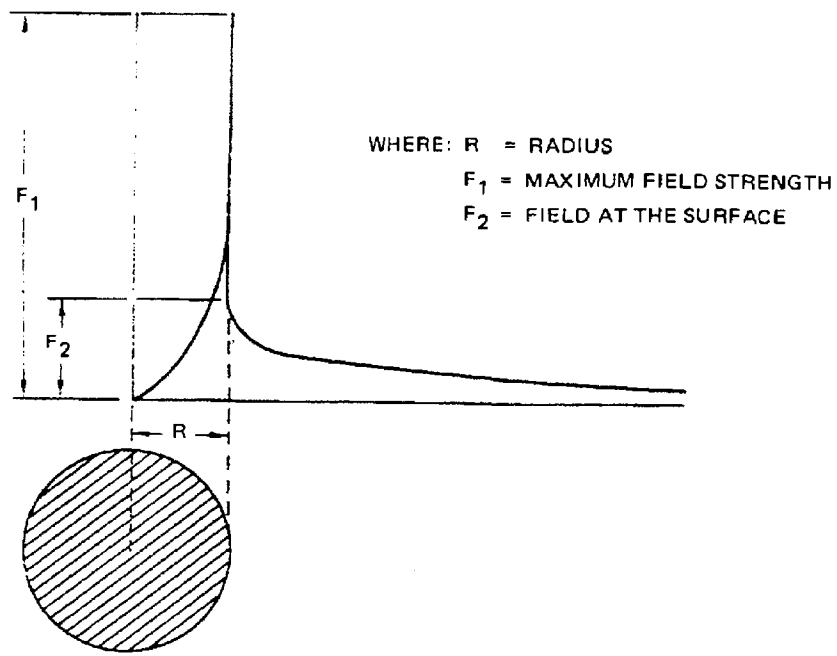

Figure 6.19: Field distribution in and around a solid magnetic conductor carrying alternating current.

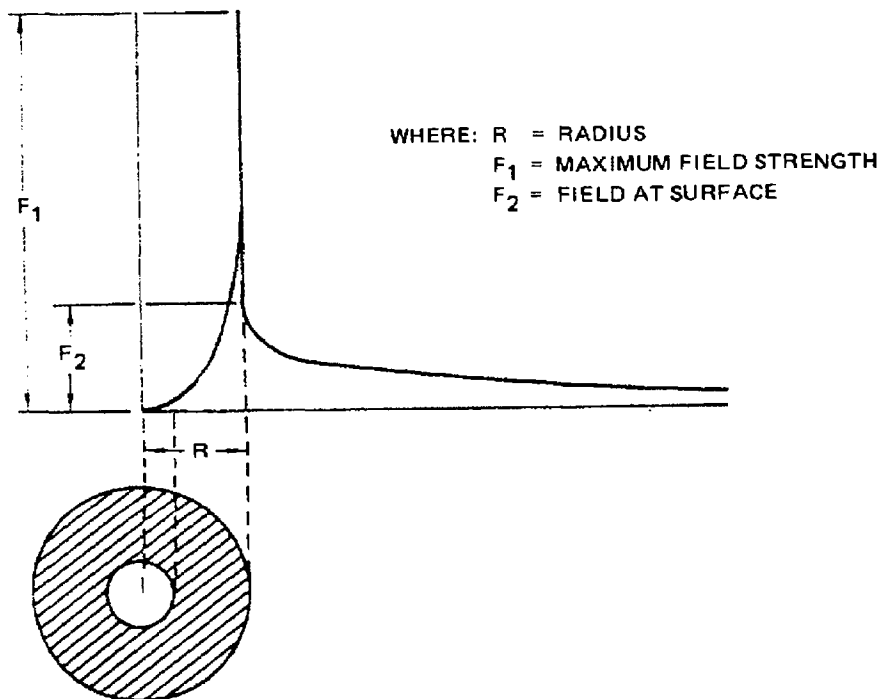

Figure 6.20: Field distribution in and around a hollow magnetic conductor carrying alternating current.

6.5.8. Alternating current residual fields

When alternating current used for magnetization is gradually reduced to zero, no residual field remains in the magnetized article. The article will be completely demagnetized. When the AC is suddenly interrupted, a residual field may remain depending upon the point in the current cycle where the interruption occurs. Distribution of any residual circular field remaining after the interruption of the magnetizing AC will be approximately the same as that shown in Figures 6.19 and 6.20.

6.5.9. Solenoid

A solenoid is a long tightly wound, cylindrical coil of wire. The magnetic field produced by a solenoid is shown in Figure 6.21. The lines of force are continuous as in a bar magnet. The field in the middle of the solenoid is uniform and much stronger whereas it is negligibly weak outside the solenoid.

Solenoid is an air-cored coil, the axial length being several times greater than the diameter of the turns comprising it. The magnetic field strength of the coil is proportional to:

- (1) The number of turns.
- (2) The magnitude of the current.
- (3) The radius of the coil.

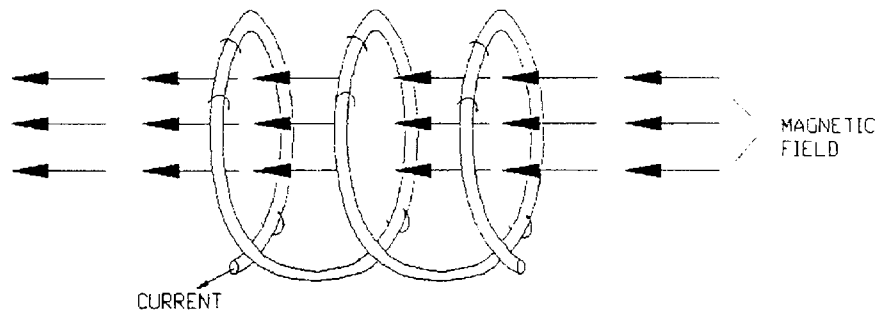

Figure 6.21: Field around solenoid or coil.

The value of flux density B is given by the formula.

$$B = \mu_0 n I \quad (8)$$

where

μ_0 is the permeability of the free space.

n is the number of turns per unit length of the solenoid.

I is the current.

6.5.10. Electromagnet

An electromagnet is a form of magnet whose magnetism lasts till the time the current is flowing into the wound coil over a soft iron piece. The coil wound in the form of a solenoid

concentrates the magnetic field in a smaller space. This field is however enhanced to a very large extent when this coil is wound over a soft magnetic material with a very high permeability. The strength of this magnetic field varies directly as the product of current and number of turns of coil per unit length. Besides the application of electromagnet as magnetizing units for magnetic particle testing such as electromagnetic yokes, there are various other applications in industry such as relays, lifting magnets, buzzers, bells or chimes and recording heads, etc.

6.6. Magnetic flux

The closeness of magnetic lines of force existing in and around magnetized material is a measure of strength or magnetic flux in that region. A single line of force represents 1 unit of magnetic flux. Flux is symbolized by Greek letter ϕ (phi) and is measured in units called maxwells. A large unit of magnetic flux is known as weber. One weber (Wb) equals 1×10^8 lines or maxwells. Gauss and tesla are unit of flux density in CGS and SI system.

6.7. Magnetising force

Magnetization force or magnetic field intensity can be defined by the force that would be experienced by an isolated north pole of strength 1 unit when placed in that field. Field strength is measured in unit called oersted (Oe). If a magnetic pole of m units experiences a force of F dynes in a magnetic field, the strength of field at that point is:

$$H = \frac{F}{m} \quad \text{oersteds} \quad (9)$$

where 1 oersted (Oe) = 1 gilbert

The intensity of field around a long straight wire is related to the current by the formula:

$$H = \frac{I}{2\pi r} \quad (10)$$

where H is the field strength in A.t/m (amperes-turn/metre) at a point r from the wire and I is current in amperes.

6.8. Reluctance

Reluctance is a term related with the magnetism and is a measure of opposition or resistance offered by the material to the applied magnetic field or magnetization force to magnetize it. The material with high permeability has low reluctance and vice versa. Reluctance is analogous to resistance in an electric circuit. Reluctance of the material determines the magnitude of flux produced, as given by the simple relation:

$$\phi = \frac{F}{R} \quad (11)$$

where

ϕ = flux (in webers)

F = magneto-motive force in amps-turns

R = reluctance

6.9. Hysteresis

Certain ferromagnetic materials when magnetized do not return to a completely demagnetized state when the magnetizing force is removed. To completely demagnetize the material a certain reverse magnetic force must be applied unless the material is heated above the Curie point for that material or the material is mechanically worked. If a variable external field is applied to a virgin specimen and both the external field and the degree of magnetization or flux density are measured, a curve representative of the material can be plotted as in Figure 6.22. This curve is known as hysteresis curve. Hysteresis is the retardation of the magnetic effect when the magnetising force H acting on the ferromagnetic material is changed. The point at which there is no magnetization and no force applied is represented by (o). By increasing the magnetizing force in small increments the flux increases rapidly at first then slowly until the maximum flux or saturation point (a) is reached. A further increase in the magnetizing force H will not increase the flux density B . The rise in flux density is shown by the line o-a. If the magnetic force is now gradually reduced back to zero the curve (a-b) will show the decrease in flux density. However there is still some magnetism remaining in the specimen represented by point (b). The amount of this magnetism is indicated by the distance (o-b) and is called the residual magnetism. If the magnetizing current is now reversed and slowly increased in value the flux density (residual magnetism) within the specimen decreases and is back to zero at point (c). By further increasing the magnetizing force the specimen becomes magnetized in the opposite direction until once again saturation is reached at point (d). If the magnetizing force is again gradually reduced to zero the flux density is reduced a certain amount to (e), however, the specimen will still retain some residual magnetism represented by o-e. If we now steadily increase the magnetic force in its original direction the residual flux density is reduced to zero at point (f) and then increases to the original saturation point (a). The curve represented by the lines a, b, c, d, e, f, is called a hysteresis curve or hysteresis loop.

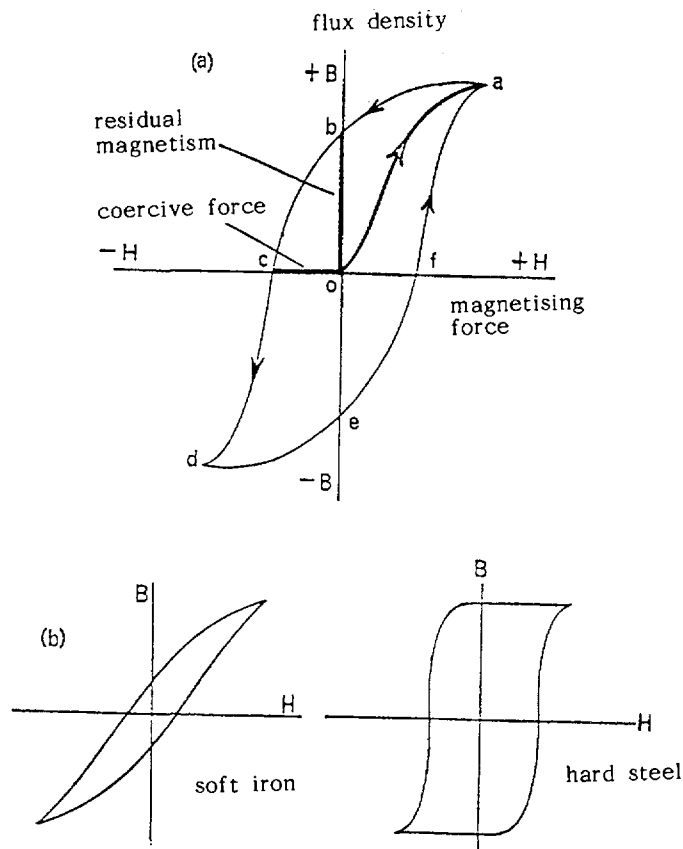

Figure 6.22: Hysteresis loops for typical ferromagnetic materials.

6.10. Magnetic field characteristics

6.10.1. Remanence

Whenever a magnetic material is subjected to magnetic field it is magnetized to a certain level. Different materials retain a certain degree of magnetism after the removal of such fields. The level of residual magnetism is a measure of its remanence value. Hard materials have higher remanence as compared to those magnetically soft materials. A desirable material to be a permanent magnet is to have high remanence value. Materials with slender hysteresis curves normally possess high remanence.

6.10.2. Permeability

“Permeability” is the term used to refer to the ease with which a magnetic field or flux can be set up in a magnetic material. For a given material, it is not a constant value but a ratio. At any given value of magnetizing force, permeability, μ , is B/H , the ratio of flux density, B , to magnetizing force, H .

Several permeabilities have been defined, but material permeability, maximum permeability, effective (apparent) permeability and initial permeability are used with magnetic particle testing.

Material permeability

Material permeability is of interest in magnetic inspection with circular magnetization. Material permeability is the ratio of the flux density, B to the magnetizing force, H , where the flux density and magnetizing force are measured when the flux path is entirely within the material. The magnetizing force and the flux density produced by that force are measured point by point for the entire magnetization curve using a fluxmeter and a prepared specimen of material.

Maximum permeability

For magnetic particle inspection, the level of magnetization generally is chosen to be just below the knee of a normal magnetization curve for the specific material; the maximum material permeability occurs near this point. For most engineering steels, the maximum material permeability ranges from 500 to 2000 (or more) gauss per oersted. The 500 value is for series 400 stainless steels. Specific permeability values for the various engineering materials are not readily available. Even if they were, they could be very misleading. To a large extent, the numerous rules for this consider the variation in permeability, so that knowing permeability values is not a prerequisite for magnetic particle inspection.

Effective permeability

Effective (apparent) permeability is the ratio of the flux density in the part to the magnetizing force, when the magnetizing force is measured at the same point in the absence of the part. Effective permeability is not solely a property of the material but is largely governed by the shape of the part and is of prime importance for longitudinal magnetization.

Initial permeability

Initial permeability is that permeability exhibited when both the flux density B , and the magnetizing force, H , approach zero. With increasing magnetizing force, the magnetic field in the part increases along the “virgin” curve of the hysteresis loop.

6.11. Saturation

This term refers to the level of magnetization of the magnetic material beyond which any further increase in the magnetization force will not produce any increase in the magnetic flux. At this stage, all the magnetic domains become aligned in the direction of magnetic field. When the external field is removed many of the domains remain oriented in the same direction and thus the material retains residual magnetism.

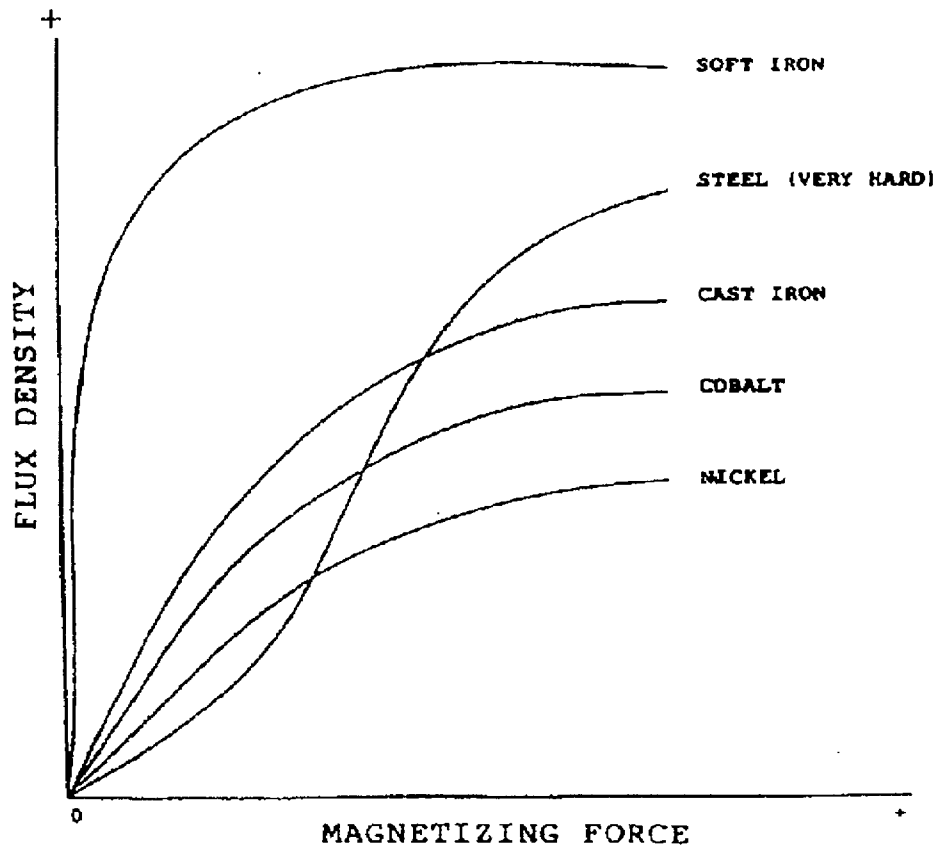

Figure 6.23: Saturation of various materials.

6.12. Normal and tangential components of the magnetic field

In order that a good indication due to magnetic leakage field is developed; the field strength and direction must be adequate and favourable in relation to size and direction of the discontinuity. It is thus important to know the field distribution and strengths inside the part or at the surface.

The tangential component of H is that component of the field having direction parallel to the surface of the part. Since the value of the tangential component of H is the same on either side of the boundary between the steel and the air, the value measured in air is also a measure of the field strength close to the surface inside the part. If the permeability of the steel is known the flux density can be calculated. The magnetic field meter designed to measure the tangential component of the field is based on Hall effect principle. When a current is passed through a plate of metallic or semi-conducting material in a magnetic field, a voltage is produced at right angles

to the current flow direction and the field direction. This is known as the Hall effect and gives a means of detecting and measuring the strength of magnetic fields. The voltage, V , produced is given by the formula:

$$V = R I H/t \quad (12)$$

where

I is the current in amperes,

H is the magnetic field strength expressed as amperes per metre,

t is the thickness of the plate in metres,

R is the Hall coefficient of the material of the plate.

Different materials have different coefficients and for the measurement of magnetic fields suitable elements can be made from germanium, indium antimonide and indium arsenide. Commercial instruments are available for checking magnetic fields using this principle. The tangential magnetic field is measured directly or after amplification of the output signal. In choosing an instrument the following points should be borne in mind. The scale of the instrument should be calibrated in units of magnetic field and a standard magnet should be provided for standardization. The range of the instrument should provide accurate measurements over the range from 80 A/m to 8000 A/m for alternating as well as constant fields.

6.13. Electromagnetic waves

Light is a form of electromagnetic radiations which is due to the moving electric and magnetic fields. The visible light consists of such waves with frequencies between 3×10^{12} cycles/sec and 8×10^{12} cycles/sec. Human eye cannot respond to frequencies higher or lower than these. The electromagnetic spectrum is as shown in Figure 6.24.

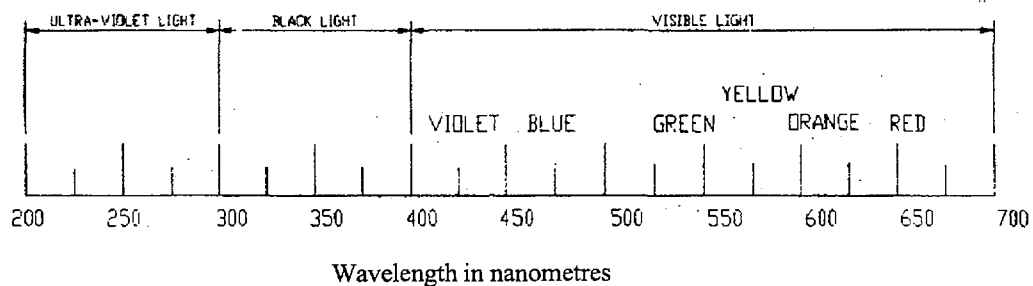

Figure 6.24: Electromagnetic spectrum.

6.13.1. Visible and ultraviolet light

As is evident from the Figure 6.24 the ultraviolet region is located in the wave length region between 200–400 nanometre. The black light region chosen lies in the lower wavelength of ultraviolet light and is between 320–400 nm region of the electromagnetic spectrum. The eye is relatively unresponsive to black light particularly when visible light is present. The functional aspect is that the fluorescent coating on the ferromagnetic particles absorb the black light and re-emit the absorbed light as visible light in the yellow green region of visible light spectrum.

6.14. Terminology and abbreviations

Most of the terms relating to the magnetism have been discussed in the related sections of the chapter. Few more are described as under:

- i) Ampere per Meter

The SI unit of magnetic field and magnetization is A/m.

- ii) Ampere Turn (magnetomotive force)

A unit of magnetomotive force in the metre-kilogram-second (M.K.S.) system defined as the force of a closed loop of one turn when there is a current of 1 ampere flowing in the loop.

- iii) Conductivity

The ratio of the electric current density to the electric field in a material, also known as electrical conductivity.

- iv) Coulomb

A unit of electric charge, defined as the amount of electric charge that crosses a surface in 1 second when a steady current of 1 absolute ampere is flowing across the surface. This is the absolute coulomb and has been the legal standard of quantity of electricity since 1950. The previous standard was the international coulomb equal to 0.999835 absolute coulomb.

- v) Gauss

Unit of magnetic induction in the electromagnetic and gaussian system of units, equal to 1 maxwell per square centimetre, or 10^{-4} weber per square metre also known as ab tesla (abt) gauss.

- vi) Gilbert

The unit of magnetomotive force in the electromagnetic system equal to the magnetomotive force of a closed loop of one turn in which there is a current of $1/4\pi$.

- vii) Henry

The M.K.S unit of self and mutual inductance equal to the self inductance of a circuit or mutual induction between two circuits if there is an induced electromotive force of 1 volt when the current is changing at the rate of 1 ampere per second.

- viii) Maxwell

A centimetre-gram-second electromagnetic unit of magnetic flux equal to the magnetic flux which produces an electromotive force of 1 ab volt in a circuit of one turn linking the flux as the flux is reduced to zero in 1 second at a uniform rate.

Abbreviated Mx.

$$1 \text{ weber} = 10^8 \text{ Maxwell}$$

ix) Oersted

The unit of magnetic field strength in the centimetre-gram second electromagnetic system of units equal to the field strength at the centre of a plane circular coil of one turn and 1 centimetre radius when there is a current of $1/2$ ab.amp in the coil.

x) Tesla

The international system unit of magnetic flux density equal to one weber per square metre symbolized by T.

xi) Weber

The unit of magnetic flux in the M.K.S. system equal to the magnetic flux which linking a circuit of one turn, produces in it an electromotive force of 1 volt as it is reduced to zero at a uniform rate.

6.15. Some derived units and abbreviations

(1)	Force	Newton	$N = \text{kg.m/sec}^2$
(2)	Work/Energy	Joule	$J = \text{N.m}$
(3)	Power	Watt	$W = \text{J/s}$
(4)	Electric charge	Coulomb	$C = \text{A.s}$
(5)	Electrical potential	Volt	$V = \Omega/\text{A}$
(6)	Electric Capacitance	Farad	$F = \text{As/V}$
(7)	Electric Resistance	Ohm	$\Omega = \text{V/A}$
(8)	Frequency	Hertz	$\text{Hz} = \delta^{-1}$
(9)	Magnetic flux	Weber	$\text{Wb} = \text{Vs}$
(10)	Magnetic flux density	Tesla	$T = \text{Wb/m}^2$
(11)	Inductance	Henry	$H = \text{Vs/A}$
(12)	Luminous flux	Lumen	$\text{Lm} = \text{Cdsr}$
(13)	Illumination	Lux	$\text{Lx} = \text{Gn/m}^2$

7. METHODS AND TECHNIQUES (MT)

7.1. Methods of magnetization

Consider the simplest shape of specimen, namely, a cylindrical bar; a magnetic field in it may be one of two kinds. It may be circular or longitudinal. Furthermore, it is evident that as the flaw plane must be substantially at right angles to the field, the longitudinal field or flux will show up a circular or circumferential crack, and the circular field will show up a longitudinal crack.

7.1.1. Longitudinal magnetization

A magnetic field wherein the lines of force traverse the part in a direction essentially parallel with its major axis. All such means of magnetization of the test parts which result in the longitudinal fields are called methods of longitudinal magnetization. Some of such means are electromagnetic yokes (AC and DC), coil magnetization (flexible and rigid) and magnetic flow techniques.

When a longitudinally magnetized object contains a transverse discontinuity, a leakage field is produced that attracts magnetic particles and forms an indication. Figure 7.1 illustrates a typical coil found in magnetic particle test systems used to locate transverse discontinuities.

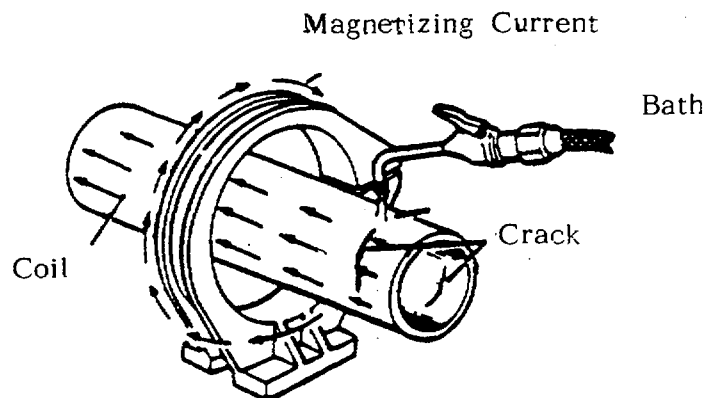

Figure 7.1: Longitudinal magnetization (coil shot).

7.1.2. Circular magnetization

The circular magnetization in a part results from current passed directly through the part or through a central conductor. The lines of magnetic flux are fully contained within the material and emerge as leakage fields only at surface breaks or discontinuity site.

Recently, with improvement to magnetic particle equipment it is now possible to introduce both circular magnetism and longitudinal magnetism in such close sequence as to perform magnetic particle inspection with one step. This is known as "multidirectional magnetism". Discontinuities oriented both ways, longitudinal and transverse, can be observed at the same time, due to flux leakage's building and collapsing with such rapidity to be visible in both directions.

7.2. Magnetization techniques

7.2.1. Permanent magnets

Magnetic materials such as hard steel and some alloys, offer high resistance to magnetization due to their low permeability but all the same possess inherent characteristic of retaining the magnetism for some times to come. Permanent magnet in the form of horse shoe is used to inspect the material. The field induced in the test object is longitudinal. Discontinuity with aor axis lying perpendicular or up to about 45 degrees to the direction of field shall be detected.

The actual strength of the field at any point depends on the strength of magnet and the distance between the poles. In case of inspection using permanent magnets the distance between their poles cannot be varied nor the actual strength of the magnet. For these facts their use is very limited and is made for the inspection of active high pressure gas pipelines.

7.2.2. Electromagnets

With yoke magnetization a magnetic field from a coil system is generated over the poles of an iron core and then transmitted into the test object. The iron core and the workpiece form a closed magnetic circuit. The magnetic field lines flow in the test piece in a direct connection line between the poles thus enabling transverse cracks to be detected. For a successful inspection, magnetization in two directions transverse to each is required. With yoke magnetization, burning of the test piece is avoided because only the magnetic field is transmitted into it, no current enters the test piece. Furthermore, yoke magnetization can be used for test objects with non magnetic surface layers provided the layer thickness is not greater than 40 μm . Figure 7.2 illustrates magnetization by an electromagnetic yoke.

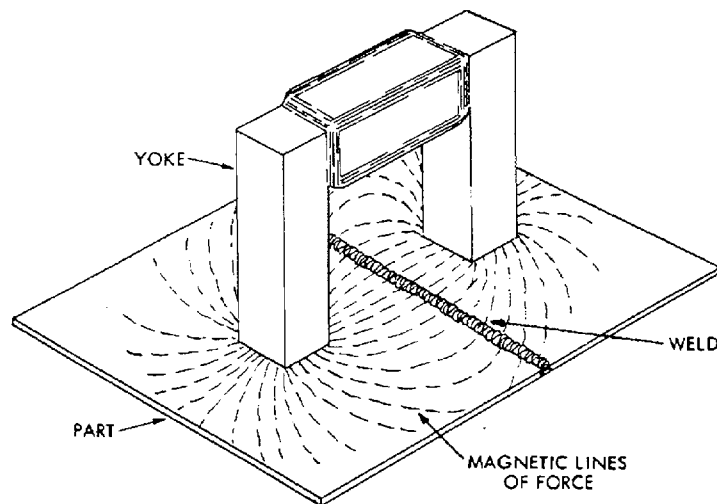

Figure 7.2: Electromagnetic yoke.

7.2.3. Coils

Rigid coils

A pre-wound coil of few turns is used to create longitudinal field in the part when placed within it. The field direction is parallel to the axis of the coil itself favouring the detection of flaws basically in a direction transverse to the axis of the coil Figure 7.3. The effective area of inspection by coil magnetization is approx. 6 inch to 9 inch (15 to 23 cm) on either side from the centre of the solenoid or coil. The current requirements for inducing a longitudinal field into a part are often calculated by the following relations.

- a) Parts positioned towards the side of the coil (low fill factor)

$$\text{Ampere-turn} = NI = K/(L/D)$$

$$\text{Ampere-turn} = 45000/(L/D) (\pm 10\%) \quad (1)$$

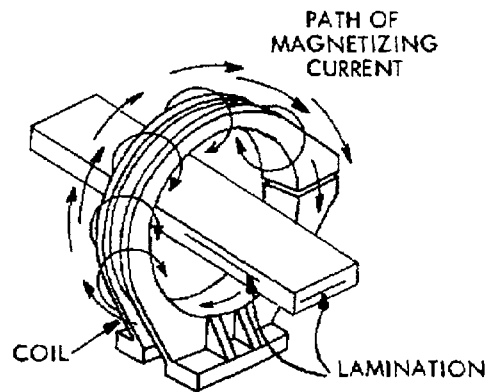

Figure 7.3: Magnetization by coil shot.

or Amperes = Ampere-turns/Number of turn.

where

L = Length of the cylindrical shape test piece.

D = Diameter.

K = constant (45000).

The above relationship is true provided the following conditions are met.

- Cross sectional area of the part is not greater than one tenth the area of the coil opening.
- Part or section of part to be magnetized is no more than 18 inch (46 cm) long.
- Part has a L/D ratio less than 4 but not less than 2.
- Part is positioned in coil with its length parallel to the applied field (coil axis).

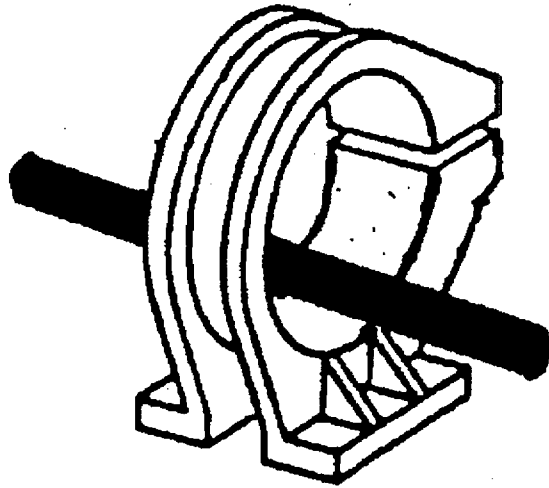

Figure 7.4: Part positioned towards the side of the coil (low fill factor).

- b) Parts positioned in the centre of the coil (low fill factor)

$$NI = 43000R / \mu \text{ (effective)} (\pm 10\%) \quad (2)$$

where

N = number of turns

I = current in amperes

R = radius of coil in inches

$$\mu \text{ (effective)} = 6L/D - 5$$

The equation applies to parts which have a cross section not greater than 1/10th of the coil.

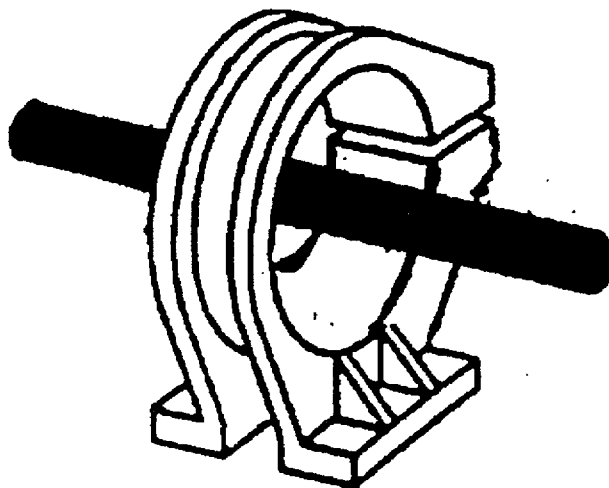

Figure 7.5: Part positioned in the centre of the coil (low fill factor).

Flexible cables (coil technique using a flexible cable)

This is a technique of magnetization in which a current carrying cable is tightly wound around the component. It favours the detection of flaws lying parallel to the cable Figure 7.6. The area to be inspected should lie between the turns of the coil thus formed. The coil shall be moved over the component at coil length intervals to ensure that the specified coverage is achieved.

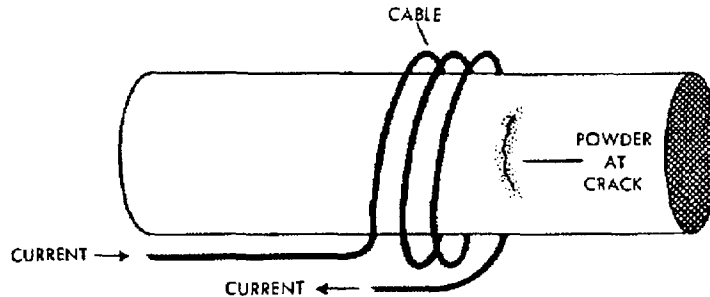

Figure 7.6: Flexible cable technique (using cable wound around the specimen).

Parts positioned within a High Fill Factor (e.g. cable wrap)

$$\text{Ampere turns (NI)} = 3500/(L/D + 2) \quad (\pm 10\%) \quad (3)$$

where

L/D is the length to diameter ratio of the part.

The conditions for the above relation to be strictly true are:

- The cross-sectional area of the part is not more than 1/10 the of the coil.
- The part is placed at the bottom of the coil.
- The permeability of the part is greater than (500 gauss/oersted) or 628.3×10^{-6} henry (H)/metre (m).
- L/D ratio equal to or greater than 3.

The flexible cable technique (using a flexible cable adjacent to the surface)

This is a technique of magnetization in which an insulated current carrying cable is laid parallel to the surface of the component, adjacent to the area to be tested. It favours the detection of flaws lying parallel to the cable or within 45° of this direction.

7.2.4. Magnetization by passage of current

When the current is passed into the magnetic test part clamped between heads of a machine or clamps at the ends of the cable carrying current the resultant field is circular. This type of field is suitable for the detection of flaws lying parallel or oriented 45° to the major axis. Figure 7.7 illustrates the magnetic fields and possible detectable orientation of flaws.

It is recommended that current should be from 700 to 900 A/in. for part diameters up to 5 in., from 500 to 700 A/in. for diameters over 5 in. and up to 15 in., and from 100 to 300 A/in. for diameters over 15 in.

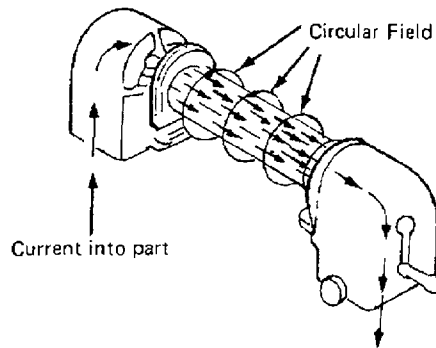

Figure 7.7: Head shot — circular magnetization (current through part).

Prod magnetization (localized circular field)

In the current flow (prods) technique a current from an external source is passed between two contact areas established on the surface of the component by means of two hand held prods, as shown in Figure 7.8.

The field produced is circular in the localized region between the prods. The prod contact technique has a special ability to produce indications which lie wholly below the surface, often quite deep. The current depends on the prod spacing and thickness of material. For prod spacing of under 19 mm, the current requirement is 90–110 A/inch, whereas for prod spacing of 19 mm and above, the current requirement is 100–125 A/inch. Prod spacing for practical examination purposes is limited to about 8 inch maximum. Prod spacing less than 3 inch is usually not practical due to banding of the particles around the prods.

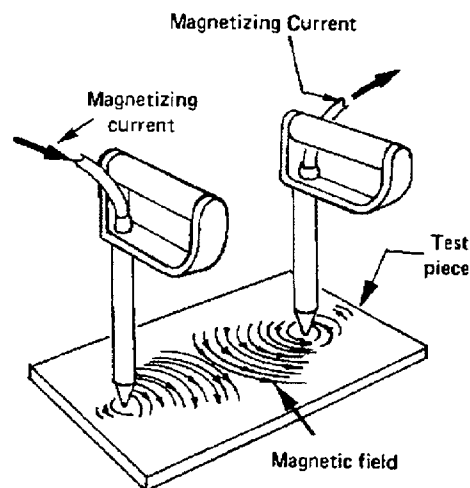

Figure 7.8: Prod magnetization.

Central conductor

The use of central conductor is made for inspection of hollow cylindrical shaped test objects. The field distribution in and around a hollow magnetic cylinder with current carrying central conductor is as shown in Figure 7.9.

The use of central conductor is suitable for inspection of many small sized cylindrical shaped articles such as springs, nuts and short cylindrical washers in one go. For objects of different diameters, the inspection is done in stages keeping different current values. The technique is employed to find longitudinal discontinuities inside and outside the cylinders and transverse cracks in the wire of the spring.

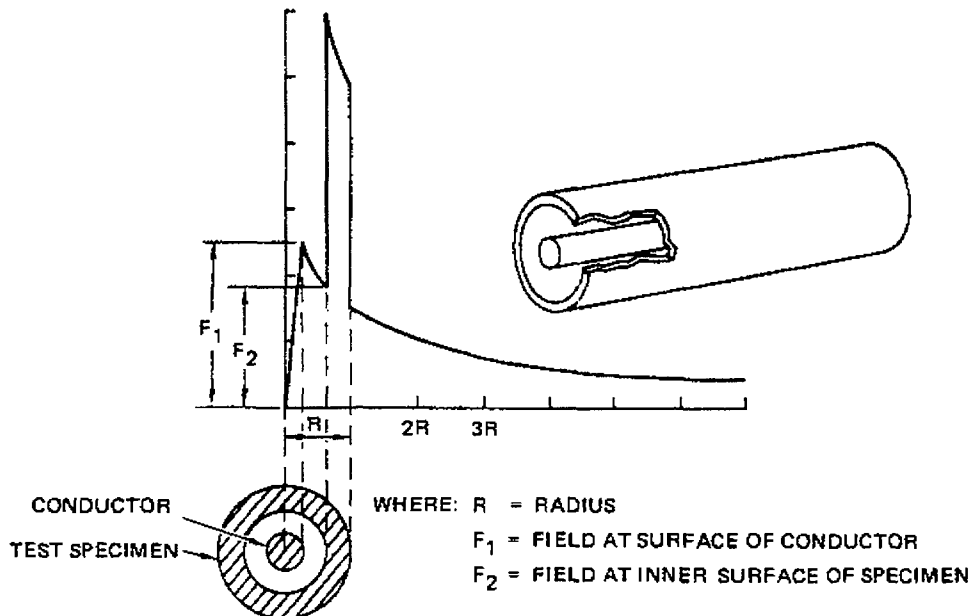

Figure 7.9: Field strength distribution in and around a hollow magnetic conductor.

7.2.5. Magnetization technique by induction

In certain situations where L/D ratio of part is such that a coil shot is not effective. Thus two step head shot and coil shot technique do not disclose satisfactorily all defects in whatever direction. Inspection of bearing race was thus made using induced current method. The experimental set up is as shown in Figure 7.10. This technique provides a complete and reliable test without making contact on the race, and requires only a single processing.

7.3. Work methods

7.3.1. Remanent fields

Certain magnetic materials such as hard steels are highly reluctant to initial magnetization but are capable of retaining considerable magnetism after the removal of the magnetic intensity or magnetization force. In such a case the field remaining known as remanent or residual is utilized to inspect the articles. The inspection media as magnetic powder in dry or wet form is applied and indications are observed. The residual method employed for highly retentive materials is not as sensitive as continuous method, but it may be sensitive enough to reveal all discontinuities that would warrant rejection. It is usually difficult to indicate sub-surface defects by this method.

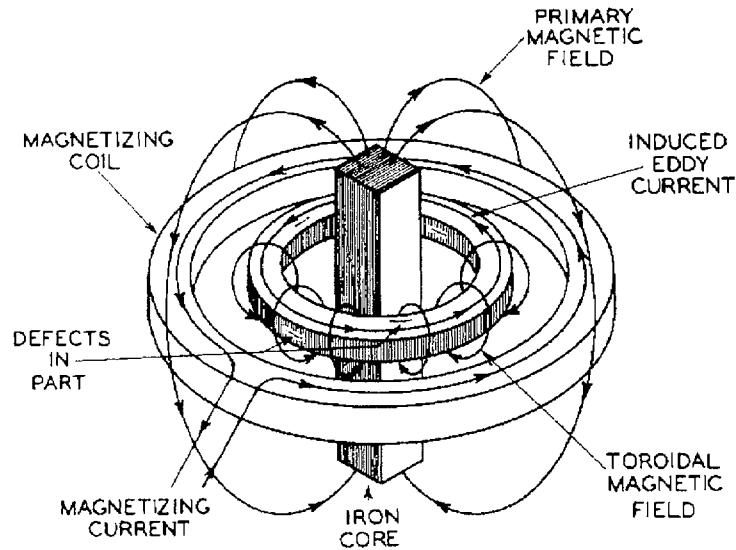

Figure 7.10: Current and field distribution in a bearing race being magnetized by the induced current method.

7.3.2. Continuous field

Continuous magnetization is employed for most applications utilizing either wet or dry magnetic powder as inspection media. The sequence of operation for "wet and "dry" continuous methods are different and are discussed as under.

Wet continuous magnetization

This method generally applies to those parts processed on a horizontal wet bench type unit. It involves bathing the parts with the inspection medium to provide an abundant source of suspended particles on the surface of the part and terminating the bath application simultaneously with the initiation of the magnetizing current. Thus there is no application of the inspection medium while the current is flowing. The duration of the current is typically of the order of seconds.

Dry continuous magnetization technique

Since the dry particles lose mobility when they contact the surface of the part, therefore, it is imperative that the part be under the influence of the applied magnetic field while the particles are still air borne and free to migrate to leakage fields. This means that the flow of the magnetizing current is started before the application of the dry magnetic particles and terminated after the application of the powder has been completed and any excess has been blown off. Examination with dry particles is usually carried out in conjunction with prod type localized magnetization, and build-up of the indication is observed as the particles are being applied.

7.3.3. Dry method

In this method the inspection medium is in the form of dry magnetic particles as fluorescent or non-fluorescent. Dry magnetic powders are normally applied with the continuous magnetizing techniques utilizing AC or HWDC magnetization currents or yoke magnetization. AC or HWDC are used for better particle mobility than DC or full wave rectified AC current. Dry powders

should be applied in such a manner that a light uniform dust-like coating settles upon the surface of the test part while the part is being magnetized. Usually specially designed powder blowers and hand powder applicators are employed. The dry magnetic particles technique is excellent for surface and near surface discontinuities. The dry powders are heat resistant and many powders are usable at temperatures of up to 600°F (315.6°C).

7.3.4. Wet method

The method incorporates the use of fluorescent or non-fluorescent magnetic particles suspended in a vehicle (carrier fluid) at a recommended concentration applied either by spraying or flowing over the areas to be inspected during the application of the magnetization current (continuous method) or after turning off the field current (residual technique). The bath concentration for fluorescent particles should be 0.1 to 0.5 mL and 1.2 mL to 2.4 mL of vehicle (per 100 cc) as recommended by ASME code for non-fluorescent particles unless otherwise specified by the particle manufacturer. The suspension vehicles are low viscosity oil or conditioned water. Oil vehicles to be used in wet magnetic particle examinations should have the following characteristics:

- Low viscosity, in order not to impede particle mobility.
- Minimum flash point of 140°F (60°C) in order to minimize fire hazards.
- Low inherent fluorescence if used with fluorescent particles, that is, it should not interfere significantly with the fluorescent particles.
- Odourless to be not objectionable to the user.
- Non-reactive, that is it should not degrade suspended particles.

Water may be used as a vehicle (carrier fluid) for wet magnetic particles provided suitable conditioning agents are added which provide proper wet dispersing, in addition to corrosion protection for the parts being tested and equipment in use. The following are recommended properties for water vehicles containing conditioning agents for use with wet magnetic particle examination:

- Impart good wetting characteristics.
- Impart good dispersability; it should thoroughly disperse the magnetic particles without the evidence of particle agglomeration (lumping of powder).
- Minimize foaming; it should not produce excessive foam which would interfere with indication formation or cause particles to form scum on the foam.
- Noncorrosive; it should not corrode parts to be tested or the equipment in use.
- Low viscosity; the conditioned water should not exceed a maximum viscosity of 5 cSt (5 centi Stokes) at 100°F (37.8°C).
- Nonfluorescent; the conditioned water should not fluoresce if intended for use with fluorescent particles.

7.4. Testing techniques

7.4.1. Testing techniques for work pieces of differing alloy, shape and condition

The magnetization by coil shot and circular field work quite satisfactory regardless the size of the object. However for very large parts their application becomes impracticable. In this case

the diameter of the coil needs to be very large since one of the restrictions made in the empirical relations (1–3) is the cross-sectional area of the part not to be greater than 1/10th of the cross sectional area of the coil. Thus for a six inch shaft this would require a 19 inch coil and for a 12 inch diameter part, the coil diameter has to be 38 inch. Similarly the current required becomes very large for larger parts. In case of circular magnetization there is a simple rule of subjecting the part to a current of 1000 Amps per inch of the part which means a requirement of 12 000 Amps for a 12 inch dia. part. For such levels of currents the sources are normally not available and have to be procured. Furthermore these rules apply to uniform objects of cylindrical shape. For irregular shapes it becomes more difficult to predict current and field distribution. This difficulty becomes even larger for irregular shaped large parts.

7.4.2. Testing techniques with various types of current

There are basically two types of electric current in common use and both are suitable for magnetizing purposes for magnetic particle testing. These are direct current (DC) and alternating current (AC). The strength, direction and distribution of fields are greatly affected by the type of current employed for magnetization.

The fields produced by alternating current tend to be confined to the surface due to skin effect whereas the magnetic fields produced by direct current generally penetrate the entire cross section.

7.4.3. Field direction for some specific cases

The knowledge of field distribution in parts with irregular shape is required when attempting to subject it to magnetic particle examination. As the shape of the part becomes complex the problem becomes correspondingly more difficult. If we compare the behaviour of longitudinal fields in bar magnet and in the upset portion of a magnetized bar, we notice that there is a departure area of field pattern in the upset portion from a true longitudinal field. Figure 7.11.

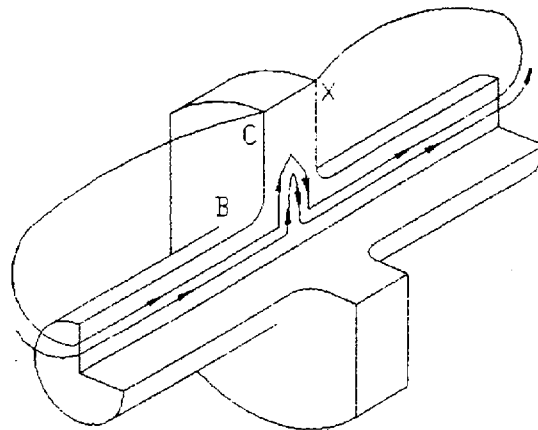

Figure 7.11: Behaviour of a longitudinal field in the upset portion of a magnetized bar.

External poles are formed at points C and X and field direction will tend to become radial along the surface BC. Such a direction is favourable for locating circumferential cracks in the fillet at B and in the surface BC but may not be favourable for locating circumferential cracks on surface 'CX'.

Other symmetrical shapes — rings

A ring is another symmetrical shape that can be magnetized both in the circular direction and in the longitudinal direction. The directions of flux for rings reflect a different concept than for a bar. A ring is conceptually a bar bent into a circle. The longitudinal flux along the length of the bar now flows around the bent bar to form the circle.

Another concept is that the ring is a slice cut from a hollow cylinder (Figure 7.12). The longitudinal flux in a ring flows around the circle in the same direction as the circular field flows in the cylinder. Therefore, to produce longitudinal magnetization in a ring, it is magnetized using a through conductor.

It is often desirable to have a longitudinal field in a large ring; however, due to its size and weight it is not feasible to use a central conductor. One alternate method is to place it in a coil with the ring in a plane perpendicular to the plane of the coil. As shown in Figure 7.13, the field will flow along two sides of the ring in a longitudinal direction.

One method for obtaining a circular field in a ring is by the direct magnetizing method of flowing the current through the ring as a conductor. Figure 7.14 shows a ring clamped between two contacts and the current flowing around each side of the ring.

The bar must be magnetized twice, rotating it about 90 for the complete ring to be magnetized. A ring can also be magnetized in the circular direction by induced magnetism. Figure 7.15 shows this method using a toroidal magnetic field, which allows the complete ring to be magnetized in one operation, instead of the two steps as required by the direct contact method.

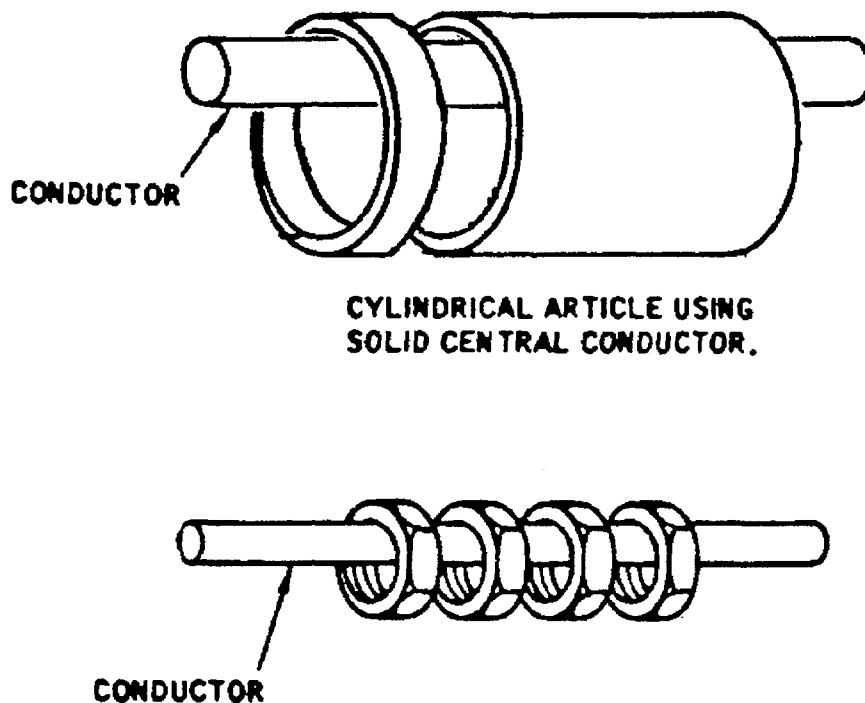

Figure 7.12: A ring is a slice of a cylinder.

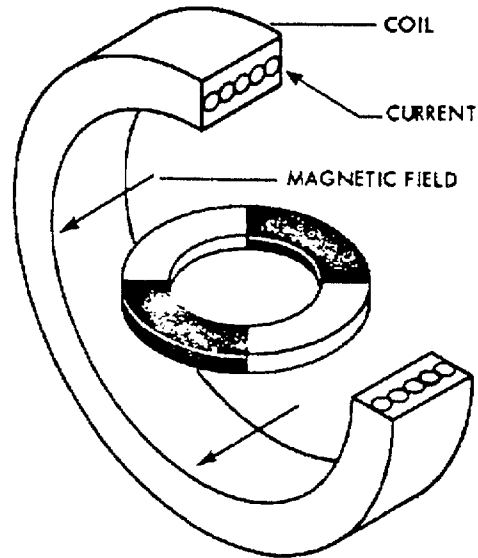

Figure 7.13: A ring magnetized in a coil.

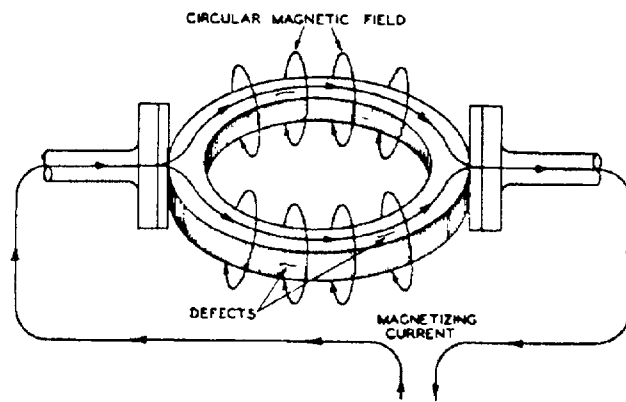

Figure 7.14: Direct contact method of magnetizing rings.

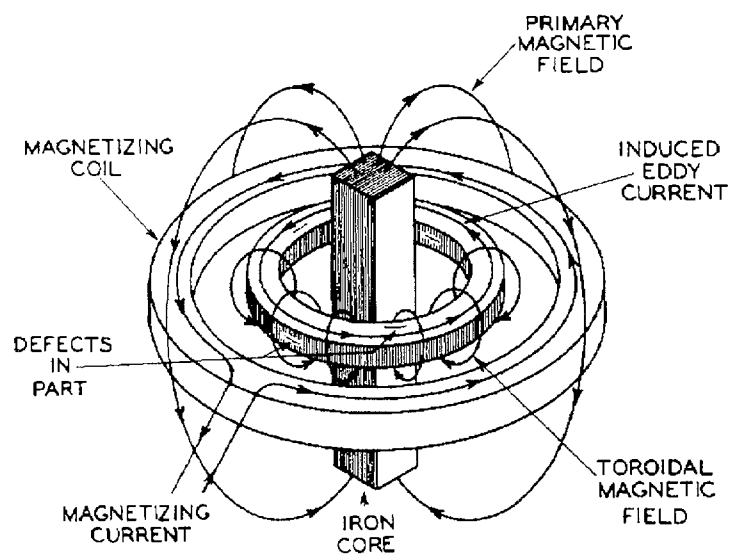

Figure 7.15: Induced current method of magnetizing ring shaped parts.

A way to induce a longitudinal field in a large ring is to wrap a cable coil around the ring. This method will enable a high flux density to be created in the ring, since the cable coil can have a number of turns. Figure 7.16 shows the flow of the current and flux in a ring with a wrapped coil. This technique is often applied on large ring forgings.

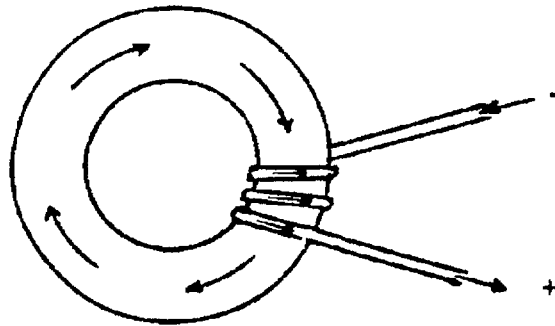

Figure 7.16: Longitudinal field induced in a large ring with a conductor cable coil.

Other symmetrical shapes — discs

The disc is another symmetrical shape found often in machinery components such as wheels, gears, and circular saw blades. The disc conceptually can be considered to be a round flat plate. The through conductor will provide a flux in the circumferential direction around the disc. Using the disc as a conductor will provide a flux across the disc. By turning the disc through 90 degrees the flux will cross the opposite part of the disc. The toroidal magnetic field can be used for saw blades where contact cannot be made with the saw teeth. Figure 3.17.

The case of a square bar circularly magnetized

The rule of magnetizing current values for circular magnetic field is based on the diameter of the round bar or longest diametrical dimensions i.e. a diagonal for a square bar. Measurement of field intensity at corners has shown that the strength is thus not uniform over a square cross section. It does not follow either the rule of decrease with distance from the centre as in the case of round bar Figure 7.18.

A rectangular bar circularly magnetized with direct current

We compare the behaviour of current distribution between a 2 inch (50 mm) square bar and a rectangular bar 2 inch (50 mm) by 6 inch (150 mm) cross-section and wish to produce a field of the same strength as for 2 inch (50 mm) square bar. If we interpret the 1000 ampere/inch (40 ampere/mm) rule as applying to longer dimension of cross section of such a bar, a current of 6000 amperes is indicated. When such a bar was subjected to 6000 DC magnetizing current, on comparison of field intensity measurement of tangential component of H measured and compared with 2 inch (50 mm) square bar the field strength values found at various points were as under Figure 7.19.

- The field strength at the corners of 2 by 6 inch (50 by 150 mm) bar and the 2 by 2 inch bar was approximately same.
- The field at the centre of the 6 inch (150 mm) face of the rectangular bar was 1.75 times the field at the centre of the 2 inch (50 mm) face of the 2 inch (50 mm) bar.

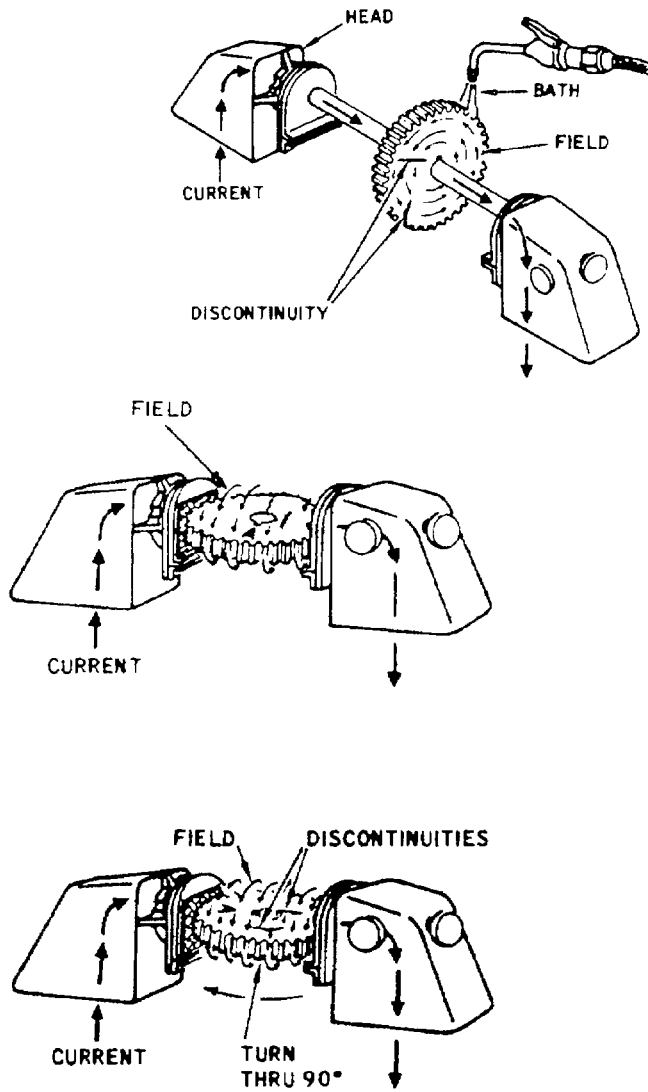

Figure 7.17: Magnetization of disc type test specimens.

SQUARE BAR, CIRCULARLY MAGNETIZED WITH D.C.

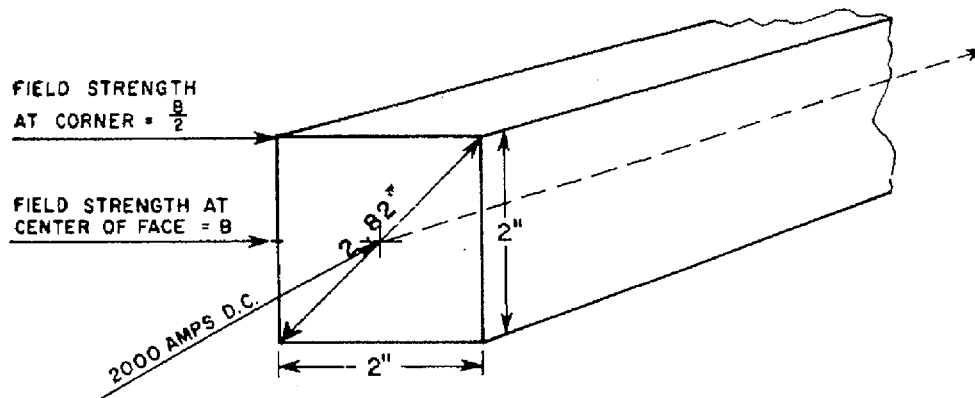

Figure 7.18: Field distribution in a square bar, circularly magnetized with direct current.

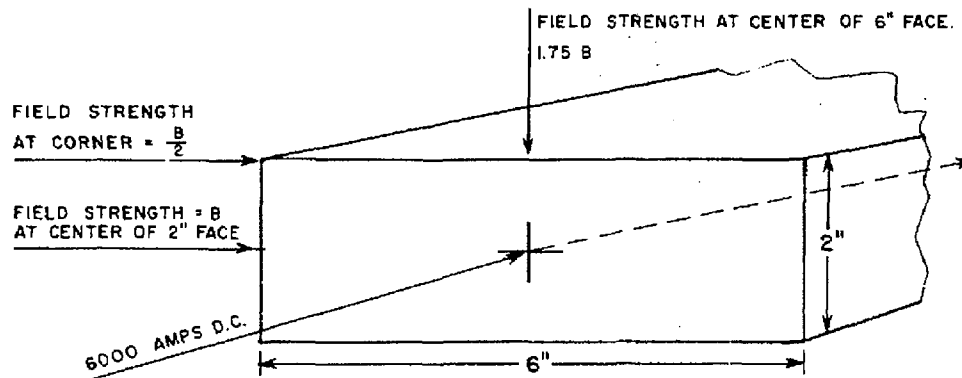

Figure 7.19: Field distribution in a rectangular bar, circularly magnetized with direct current.

7.5. Appropriate field intensity

It is an essential consideration in magnetic particle testing method to ensure the adequacy of existing fields and their direction to be favourable in relation to the size and direction of the discontinuity, in order that a good indication can be produced at leakage field points. The operator should thus have knowledge of field strengths and distribution inside the test part for a successful examination.

7.6. Test sequences

A successful examination of a part or inspection surface, when using the magnetic particle inspection method is dependant upon the close observation of the following inspection requirements in their logical sequence of application.

- (a) Preparation of the inspection surface.
- (b) Magnetization of the inspection surface.
- (c) Indicating medium selection and application.
- (d) Interpretation of discontinuities.
- (e) Demagnetization.
- (f) Post cleaning.

A further brief discussion on the above sequence and respective requirements is as under.

7.6.1. Part surface

Part surface condition has an influence on the sensitivity of the magnetic particle testing method. Surface conditions such as being rough, smooth and painted ask for relevant measures to obtain best conditions before starting a particular method.

7.6.2. Magnetization of the inspection surface

There has to be a choice made between continuous method (dry or wet) and residual. Similarly there is a need of strict control and check on the choice of magnetizing current, direction of the field and values of current.

7.6.3. *Indicating medium selection and application*

Choice has to be made between dry powder and wet inspection medium as well as for their being fluorescent or non fluorescent. All these considerations are essential because they have a direct influence on the overall sensitivity desired.

7.6.4. *Interpretation of indications*

In magnetic particle testing an indication could be any magnetically held magnetic particle pattern on the surface of the part being tested. Knowledge of some history of part's manufacture, intended use, related discontinuities and knowledge of the code help in interpretation of the indications.

7.6.5. *Demagnetization*

Ferromagnetic materials may require demagnetization before or after inspection. These may be essential in certain situations such as:

- To prepare for inspection.
- To prevent damage to moving parts.
- To prepare for subsequent magnetization.
- To prevent instrument interference.

7.6.6. *Post cleaning*

Finished parts processed with wet inks should be immediately cleaned and dried to prevent the chances of surface corrosion or wear between moving parts.

7.7. *Miscellaneous field practices*

7.7.1. *Preparation of the wet and dry suspension for coloured and fluorescent particles*

Three basic types of materials are available:

- a) The oil base pastes, either black, red or fluorescent.

These are primarily for use with oil suspensoids, though with suitable water conditioners they can be used with water. Their use is rapidly being abandoned in favour of the newer dry concentrates.

- b) Dry concentrate powders, either black, red or fluorescent.

One type is used with water as the suspensoid, and a second type for suspension in oil.

- c) Water conditioners.

These are used to suspend oil pastes in water, and to make up the quantity of conditioner in the water bath when needed.

The dry powder concentrates are now preferred for both oil and water baths. The new self dispersing particles are readily picked up by the pump circulating system, and are easily maintained in suspension.

Making up the bath for dry powder concentrate

When a new bath is to be made up for a new unit or after dumping a dirty bath from a unit in use, it is important to ensure that agitation system is clean, and, not clogged by dried particles or accumulated dirt such as lint or shop dust. Next, fill the tank with oil or water as required and operate the agitation system to make sure it is functioning properly. Measure out the required amount of powdered concentrate in the graduated cup and pour it directly into the bath liquid in the tank. The agitation system should be running and the concentrate poured in at the pump intake, so that it will be quickly drawn into the pump and dispersed. After 30 minutes of operation the bath strength should be checked with a settling test. One may have to add the concentrate or dilute if the settled material is not within desired limits.

Bath for oil paste and oil bath

The procedure is similar to that followed in the case of the dry powder concentrates, except that the paste must be weighed out instead of measured. It is transferred to a mixing cup or bowl. Add bath liquid, a little at a time, and mix, until a smooth thin slurry has been produced. This slurry is then poured into the liquid in the tank at the point where the agitation system will pick it up and disperse it. After agitating for thirty minutes the strength should be checked by a settling test as in the case of the dry powder concentrate.

Settling test

The suspension is agitated for 30 minutes to ensure an even distribution of the particles in the vehicle. Then 100 mL of the bath is pumped through the hose nozzle into the pear-shaped centrifuge tube and allowed to settle for 30 minutes. The amount of particles (measured in mL) settling in the bottom of the centrifuge indicates the concentration of solid matter (particles) in the bath. In measuring the solid matter in the centrifuge, foreign matter such as lint and dirt, which settles on top of the particles is not even considered. If the particle reading is high, liquid (vehicle) is added. If low, paste or liquid concentrate containing particles is added.

Centrifuge tube test

Low signal- to- noise ratio is the principal reason for failure to detect fluorescent indications — it is nearly impossible to detect fluorescent indications in high fluorescent backgrounds, for either automated tests or the human eye. The principal causes of low signal-to-noise ratio are: (1) excessive current density, (2) excessive magnetic particles in suspension, (3) excessive fluorescent background in the vehicle, or (4) excessive particle contamination. The settling test can detect the last three causes.

In a typical settling test, done with fresh particles, a concentration of 0.1 to 0.5 mL particles should be found in a 100 mL centrifuge tube for fluorescent particles and from 1.2 to 2.4 mL per 100 mL of vehicle for non-fluorescent particles.

The settling test may also be used to determine two of the primary kinds of bath contamination: (1) the loose fluorescent material from the particles themselves, and (2) extraneous oils (such as cutting oils) that remain on the test object after cleaning. The degree of such contamination can be monitored with a centrifuge tube that retains an initial sample of the vehicle for referencing purposes. This is then compared to a concentration test after at least one hour of settling.

Another source of contamination is sand from prior sand blasting operations, residue from grinding or shot dirt. These contamination sources are the result of inadequate pre-cleaning and can be determined by a settling test comparison.

Bath maintenance

The strength of the bath is maintained by adding paste or oil as indicated by results of the settling test. In adding paste, a thin “slurry” is first made. This procedure is identical to the procedure used in the initial preparation of the bath. Paste is never directly added to the bath because it does not disperse properly. When in use, the bath eventually becomes contaminated by dirt, lint and chips to a degree that efficient formation of discontinuity indications is hindered.

Degree of contamination is determined by the amount of foreign matter settling with the paste in the bottom of the centrifuge tube during the settling test. The bath should be checked on a regular schedule depending on the inspection volume: weekly if the volume is high; monthly if the volume is low. When the bath is contaminated beyond usefulness, it is discarded, the bath tank and the liquid system are thoroughly cleaned and a new bath is mixed. Contamination can be minimized by keeping the bath covered when not in use.

7.7.2. Techniques for checking field sensitivity

Field indicators for calibration test pieces

Different field indicators have been developed for checking the sensitivity of a particular method or technique. Some of them can be used for the calibration purposes for the equipment as well as the test pieces. Some of the well known field indicators discussed in text books and specifications are discussed in brief in the following paragraphs.

Magnetic field indicator

To be sure that a sufficient and well oriented magnetic field has been formed on the area to be inspected, the field can be measured with a special device when current magnetization is used. A magnetic particle field indicator as shown in Figure 7.20 is used to establish the adequacy of the magnetic field. The magnetization current has to be sufficient to develop the pattern in the indicator clearly. The field indicator is used by positioning the indicator on the sample while applying current and ferromagnetic particles. The production of a pattern (usually a cross) of discernible ferromagnetic particles indicates that adequate field strength has been generated in the test object.

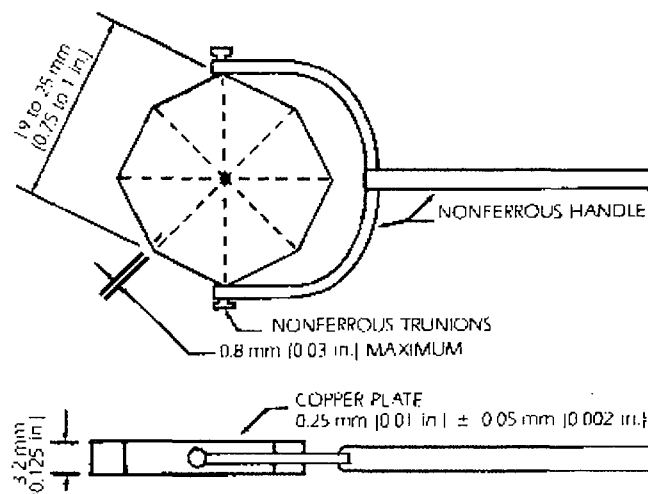

Figure 7.20: Magnetic field indicator.

Shim discontinuity standards

Shim indicators are thin foils of high permeability material containing well-controlled notch discontinuities Figure 7.21. Frequently, multiple shims are used at different locations and different orientations on the test object to examine the magnetic field distribution.

One popular version of the shim indicator is a strip of high permeability magnetic material containing three slots of different widths. The strip is placed in contact with the testing surface and shares flux with the test object. For the purposes of producing test indications, the slots in the strip act as if they were cracks in the test object. A principal limitation of this standard is that a 50 mm (2 in.) gauge length is needed.

Another type of shim (sometimes called a block) has been used in Japan since the 1960s Figure 7.22. As described in Japanese Industrial Standard G 05665, these indicators are used for examining the performance of the apparatus, magnetic particles and suspension, and the strength and direction of effective magnetic field on the surface of the test article.

The blocks are available in a variety of thicknesses and slot depths. Linear and circular slots are available. Circular slots are particularly effective when the direction of the magnetic flux is not known. The shims are taped to the test object (slotted side in close contact with the part), in areas where the strength and direction of the magnetic field are in question. The slots share magnetic flux with the test object and simulate slightly subsurface discontinuities.

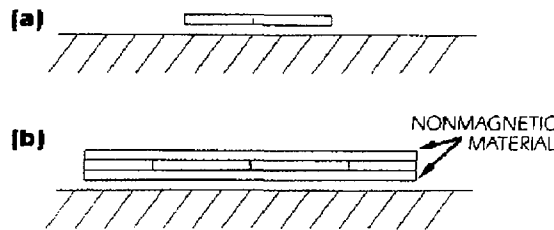

Figure 7.21: Shim indicators for magnetic field verification, (a) simple shim and (b) slotted strip.

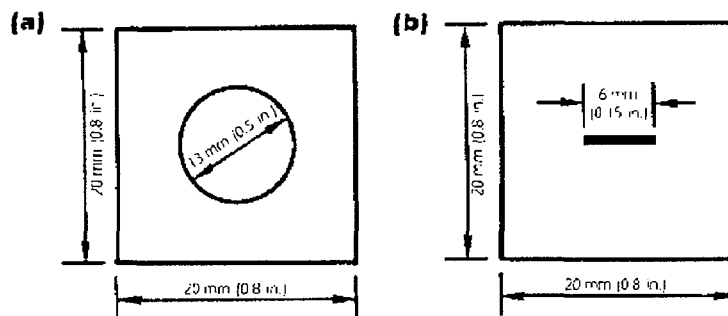

Figure 7.22: Japanese type A standard test shims, (a) circular and (b) linear.

7.7.3. Field indicators for evaluating the sensitivity of the test

Split prism test block

The prism block shown in Figure 7.23 is a reference standard containing an artificial discontinuity. Truncated half-prisms are built with one face at an angle and when two such components are bolted together, an artificial crack is formed. The sloped surface of the block can be positioned at variable distances from the conductor.

When current is passed through the conductor, the leakage field from the crack gradually weakens along the prism face. A specified amperage is applied through the conductor and the length of the magnetic particle indication is used to measure the test sensitivity.

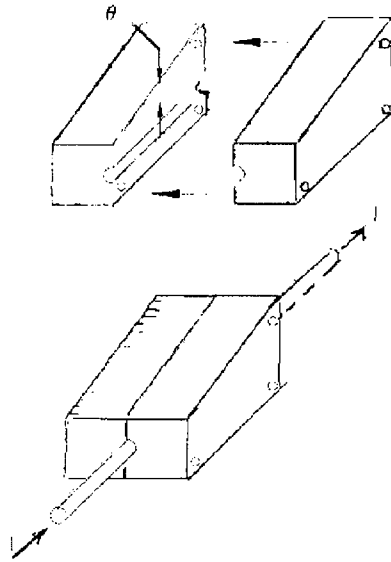

Figure 7.23: Prism sensitivity indicator.

Magnetized test blocks

Another version of the block standard consists of two ground steel blocks forming an artificial crack at their contact surfaces similar to the discontinuity formation in the split prism test block. On one of the face ends, a small permanent magnet is fixed below a brass cover, causing magnetic flux leakage from the artificial discontinuity. This leakage field decreases with greater distance from the magnet so that longer discontinuity indications reveal higher test sensitivity.

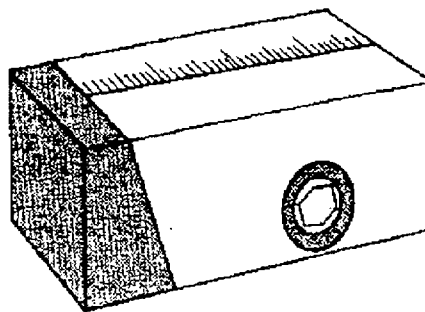

Figure 7.24: Block standard containing a permanent magnet.

Work pieces for evaluating magnetic particles

In the course of use a certain amount of magnetic particles is removed from the wet bath by clinging either magnetically or mechanically to the surface of the parts. In time, depending on the number of parts tested, this results in a bath with insufficient magnetic particles and more testing material must be added. Other reasons such as evaporation of liquid when the unit is not in use, also acts to change the bath concentration. Frequent tests for bath concentration are a most important requirement. A weak bath will result in faint indication and thus tends to reduce the severity of a discontinuity; or a faint indication which might be produced by a bath of proper concentration, might be missed entirely, if the bath is below strength.

Test blocks

Various test blocks containing a series of artificial defects, just below the surface and having graduated depths, have been developed. One version of such a device, shown in Figure 3.25, consists of a piece of soft iron having a hole drilled through it, through which a copper rod is passed.

A tapered slot, cut into the upper surface of the block and filled with a non magnetic material constitutes an artificial defect of varying depth. The block can be used either in a coil for longitudinal magnetism check or by passing current through the copper rod passed through the hole. Figure 7.25 shows the block in use for both tests. Bath strength is indicated by the length of the indication when a current of specified strength is passed. For wet continuous method, if the bath is good, and the circuits are operating correctly, the following results should be obtained.

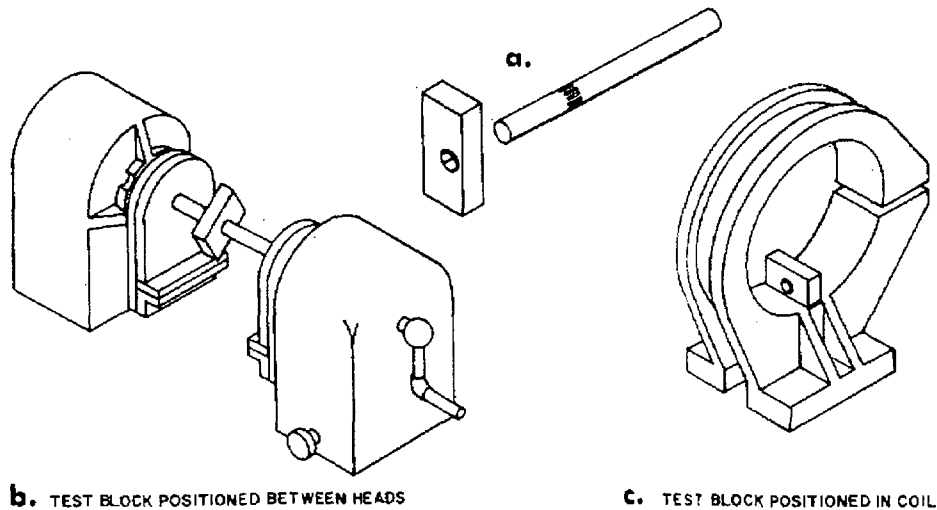

Figure 7.25: (a) Test block for measuring bath strength. (b) Test block in use between heads of unit. (c) Test block in use in coil.

For a 5 turn coil or Head (current Amp DC)	Approximate length of indication (% of defect length)
500	zero
1000	50%
1500	100%

Failure to obtain the above results could be due to one or more of the following.

- (a) Quality of the bath is poor, too strong or too weak.
- (b) Head and/or coil circuit is not operating correctly.
- (c) The technique is not being applied correctly.

Ketos ring specimen

The test ring specimen is a tool used in evaluating and comparing the overall performance and sensitivity of both dry and wet, fluorescent and non-fluorescent magnetic particle technique using a central conductor magnetization technique. As per requirements of ASME code, the magnetization current is FW-DC through a 1-3/16 inch (30 mm) diameter central conductor while applying the inspection media to the 7/8 inch (22 mm) wide circumference of the test ring Figure 7.26.

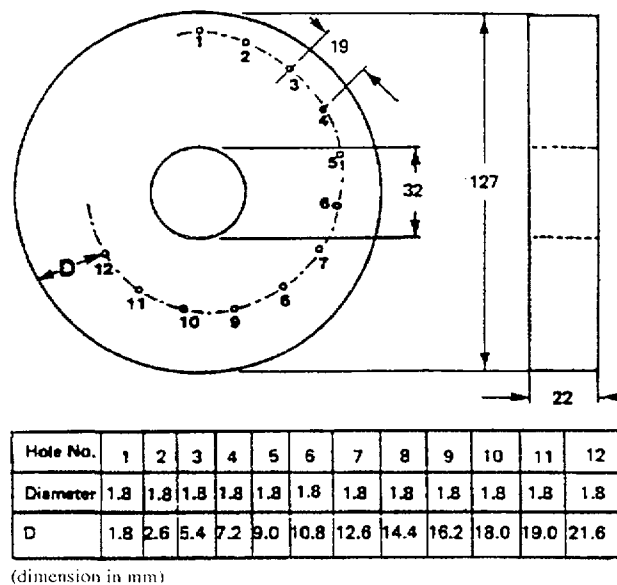

Figure 7.26: Ring specimen with article sub-surface discontinuities.

The number of indications formed on the outer rim of the ring will indicate the sensitivity of the system in use. The test ring specimen should be made from AISI tool steel cut from annealed round stock. Its hardness should be in the range of 90 to 95 HRB.

7.7.4. Reasons for demagnetization

- a) Demagnetization is required:
 - When the part is to be plated or painted. Adhering particles would interfere with these processes;
 - When the part is to be remagnetized at a lower level than the original magnetization step;
 - When parts tested will be moving parts. Particles of metal or magnetic particles could cause failure;
 - When parts are to be subsequently machined;

- When parts are to be electric arc welded; this prevents possible arc blow;
 - When the residual field will affect instruments sensitive to magnetic fields, e.g., aircraft parts.
- b) Demagnetization is not required:
- When postcleaning is a stringent requirement and all inspection materials must be removed;
 - When parts are of low retentivity, e.g. low carbon plate;
 - If the material tested consists of structural parts, e.g. weldment, large castings;
 - When the part is to be remagnetized in another direction at the same or higher level than the original magnetization;
 - When the part tested is a finished article and no external leakage field exists;
 - If the part will be magnetized anyway in a following process, e.g. held on a magnetic chuck;
 - When the part will be heat treated above its Curie point, This is 770°C (139°F) for most steels that are inspected, by magnetic particles.

Residual magnetism

Parts fabricated from ferromagnetic material retain a certain amount of residual magnetism (or remanent field) after exposure to a magnetization force. This field is dependent upon the following:

- Magnetic characteristics of the particular material, i.e. whether of high permeability or low reluctance.
- Strength of the applied magnetization force.
- Direction of the magnetization; longitudinal or circular.
- Geometry of the part.

Demagnetization methods

The basis of all demagnetization processes is subjecting the magnetized article to the influence of a continuously reversing magnetic field that gradually reduces in magnitude causing a corresponding reversal and reduction of the field in the article. Figure 7.27 shows graphically how the method works. The curve at the upper right of the drawing represents the flux in the part as indicated on diminishing the hysteresis loop. The sine wave or curve of a reversing current at the bottom of the graphs is used to generate the hysteresis loops. As the current decreases in value with each reversal, the loop shrinks and traces a smaller and smaller path. When the current reaches zero the remanent field in the part will also have approached zero.

Alternating current demagnetization

An a.c coil is the most common method of demagnetization. The coil is usually designed to operate at line voltage and frequency (usually 50 c.p.s). When the part is placed in the coil, it is subjected to a reversing field due to the cyclic action of the current. The magnitude of the field can be gradually reduced by slowly withdrawing the part from the coil, or the part can be held stationary while the coil is being withdrawn. The coil should not be de-energized until the part

has been withdrawn to a position beyond the influence of the coil. The method is advantageous for high production rates. Typical AC-demagnetizer is shown in Figure 7.28.

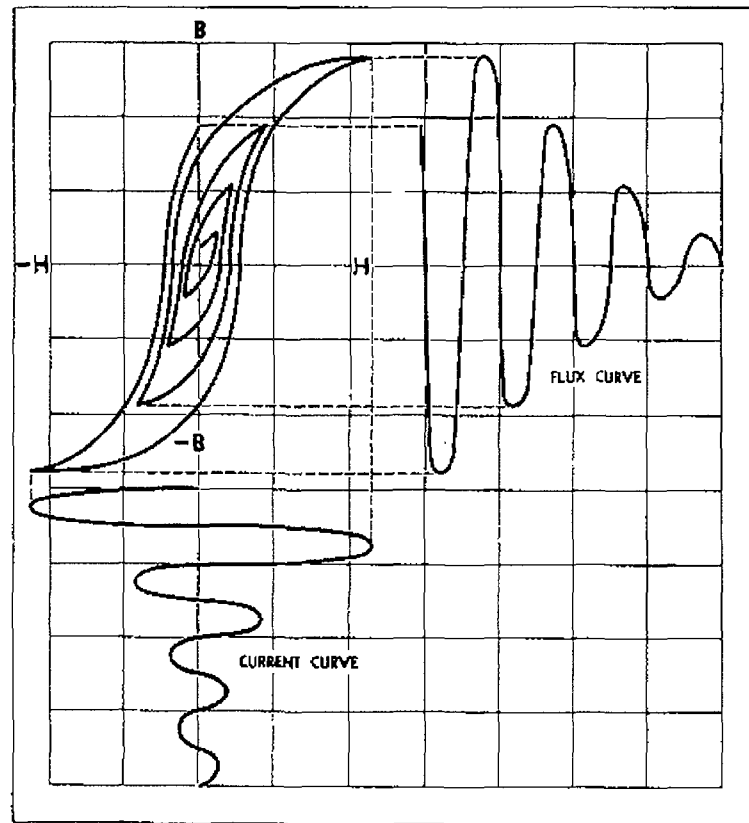

Figure 7.27: Demagnetization flux curve projected from hysteresis curve.

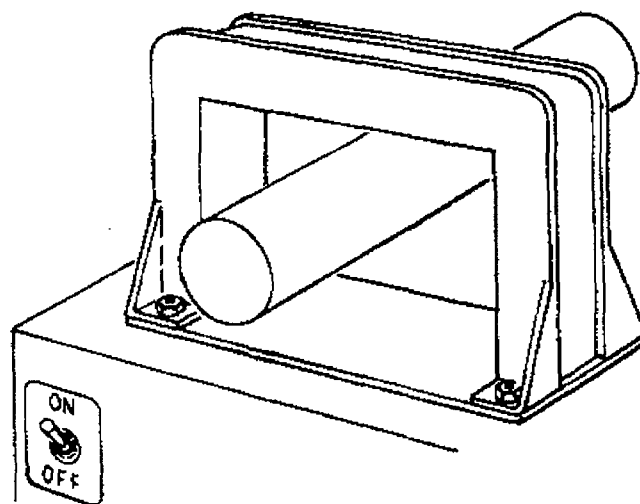

Figure 7.28: Demagnetization coil.

Reversing DC demagnetization

In demagnetization with reversed direct current, the desired magnetic field is obtained by means of a coil or passage of current through the part itself. The direct current is alternately reversed in direction and reduced in amplitude. If a coil is used, the part is left in the coil until the demagnetization cycle has been completed. The method is very effective and usually employed on articles which are difficult to demagnetize. Approximately 30 reversals and reduction in current values help in achieving reliably demagnetization of the articles.

AC circular field demagnetization

This method is similar to a.c demagnetization except the current is passed directly into the parts. The magnitude of the current is systematically reduced to zero by some suitable device. This method is used for large parts.

AC and DC yoke demagnetization

Yokes are usually used for demagnetizing small parts having very high coercive forces. They are C-shaped and are usually designed for demagnetization of a specific type of a part. Some AC yokes are similar in operation to the AC coil method whereby the part is passed between the pole faces (max. field intensity) and then withdrawn. Direct current yokes are usually based upon the reversing DC method. Some designs utilize damped oscillations to obtain the required reversing and diminishing fields.

Vibration

This means of demagnetization is not recommended, due to possible damage of the part under test.

Heating to Curie point

When ferromagnetic materials are subject to heat treating or heating above 700°C, the molecules become agitated and revert back to their unmagnetized state, effectively demagnetizing the part.

7.7.5. *Verification of the remanent fields*

Field indicator

The use of pocket sized device known as 'field indicator' is made to check and determine the relative intensity of the leakage field emanating from the part. The relative intensity of leakage field is measured by bringing the field indicator Figure 7.29 to the part and noting the deflection of the pointer. The edge of the field indicator case at pivot end of the pointer should be closest to the part being investigated. The required degree of de-magnetization is usually specified as a maximum field indicator reading.

The amount of the movement of the needle indicates the strength of the field. Some process specifications use this device to specify the degree of demagnetization desired. They often recommend a maximum of less than two divisions for critical inspection and less than five divisions for parts in which a somewhat higher residual field can be tolerated. The direction of deflection of the meter needle represents the polarity of the magnetic field.

Compass indicator

A compass is at times used for indicating the presence of external leakage fields. A compass, placed on a non-ferromagnetic surface and a magnetized part (aligned due east and west), is moved slowly toward east or west side of the compass case. The presence of the external field will cause the needle to deviate from its normal north-south alignment.

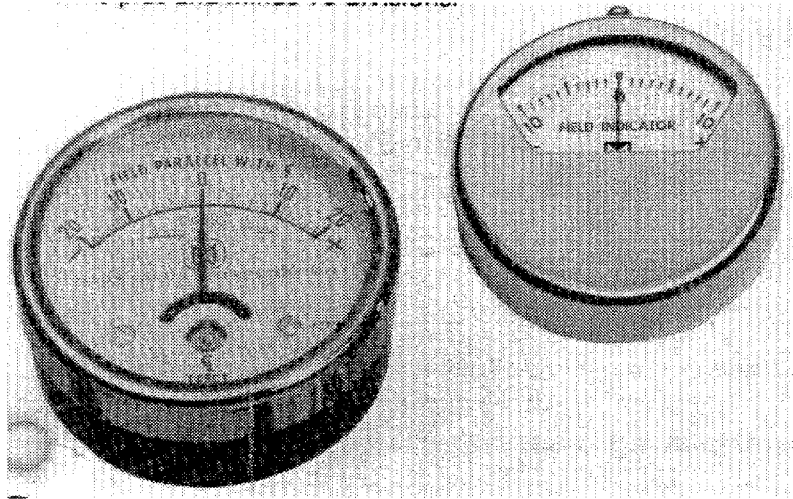

Figure 7.29: Field indicator.

8. EQUIPMENT AND ACCESSORIES (MT)

8.1. Knowledge of equipment

Many different varieties of standard magnetic particle test equipment are available for industrial use. A magnetic particle unit or system must fulfil two basic requirements.

- (a) To accurately perform a non-destructive test based on amperage requirements, test object size, magnetic field levels and suitable testing area.
- (b) To perform the test with or without operator intervention at a rate required by the particular production or inspection facility.

The following list is a summary of the choices and considerations that determine the configuration of a magnetic particle testing system for a specific application:

- Location and nature of testing.
- Particle type (wet or dry, fluorescent or non-fluorescent).
- Degree of automation desired.
- Demagnetization requirements.
- Output current requirements (types and strengths).
- Requirements of main supply line (single phase or three phase).
- Accessories needed for the application.
- Test specifications requiring verification.
- Equipment size/dimension for corresponding test jobs.
- Magnetization requirements of the test object.

Thorough understanding of the magnetic testing technique especially its capabilities and limitations plus test object's magnetic characteristics, its geometry and intended service are important factors that affect the choice of a particular system.

8.1.1. Permanent magnets

When the poles of a horse shoe magnet or a permanent magnet yoke are placed upon the surface of the ferromagnetic test specimen, the field travels through the part from one pole to other. The flux lines are relatively straight, the strength at any point depending on the strength of the magnet and the distance between the magnet. Permanent magnets in the form of yokes are normally used for areas such as active high pressure gas pipelines where safety considerations do not allow the use of prods with arcing possibilities.

Permanent magnets in the form of yokes should be capable of lifting a load of 18 kg at the poles spacing greater than 75 mm. Some of the drawbacks to the use of permanent magnets are:

- It is not possible to vary the strengths of the field.
- Large areas or masses can not be magnetized with enough strength to produce satisfactory indications.
- If the magnet is of very strong field it may be difficult to remove it from contact with the part.

8.1.2. Electromagnetic yoke

The basic principle is similar to that discussed above. A yoke is a U-shaped piece of soft magnetic material, either solid or laminated, around which is wound a coil carrying the magnetizing current Figure 8.1.

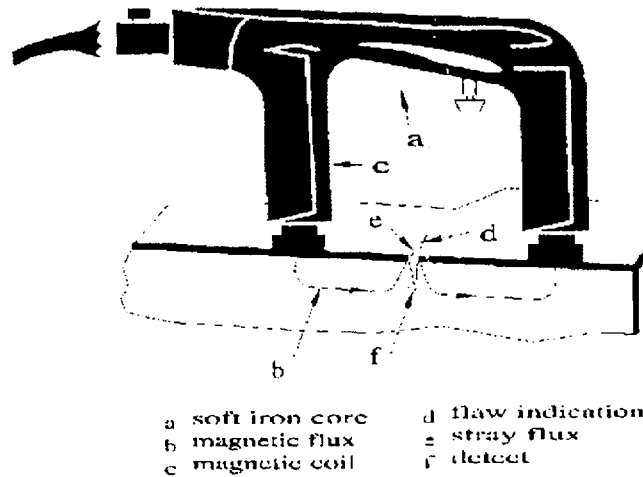

Figure 8.1: AC yoke.

The hand held electromagnetic yoke supplies a high intensity, unidirectional magnetization field between the poles when placed on a magnetic part and energized. Such yokes are often specified by their lifting power or by the tangential field between the legs. The lifting power of the DC yokes and the AC yokes should be 18 kg and 4.5 kg respectively at the suitable poles spacing. Unlike permanent magnetic yokes there is no lifting problem in removing the test part in the unmagnetized condition, which is possible by switching off the current. Both AC & DC yokes are available. The DC yoke operates from a 12 volt automotive battery drawing a current of 12 amperes. This yoke is primarily used for the following purposes:

- To locate surface cracks of moderate to large size.
- For locating cracks in welds or castings.
- For locating fatigue cracks during overhaul of large assemblies. Very recently yokes with four poles have been developed in which by switching between the poles in pairs at right angle to each other discontinuity detection in all directions can be performed in a single step.

8.1.3. Portable and stationary equipment

Portable equipment

Portable units are some times referred as mobile when mounted on carts due to their weight exceeding a certain limit. Portable equipment is available in a variety of sizes, shapes and weights. Portable equipment operates on the same principles as stationary equipment. Portable equipment is usually operated on 240 volt AC and is rated between 500 and 1500 amperes output, depending on model and type (Figure 8.2).

Different models provide DC or AC/DC output. The step-down transformer for demagnetization is omitted.

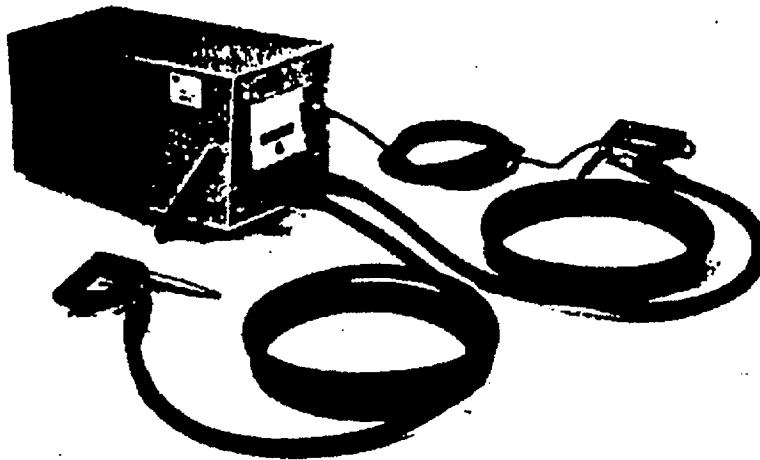

Figure 8.2: Portable unit (usually 500 to 1500 amps capacity AC and HWDC).

Mobile equipment

Often it is necessary to bring the test equipment to an article located in another area. The type of equipment used for such purpose is mobile and sturdy and is able to provide various types and methods of required tests. The following paragraphs deal with mobile equipment and its capabilities.

a) **Current and voltage selection**

A typical mobile equipment operates on 240 or 440 volt AC and provides both AC and half-wave DC variable up to approximately 3000 amperes. Selection of AC or HWDC is easily changed by switching cables on output lugs located on the front.

b) **Method used with mobile equipment**

Prods are usually used with mobile equipment. However, clamps and magnetic leeches serve the same purpose. Yokes, or the wrapping of a cable into a coil, can be used. Also, a central conductor may be hooked up between the two cables, if needed.

While the dry magnetic particle powder is most frequently used with this type of equipment, the wet method can also be employed by the use of an external tank or expendable, one-time materials.

This unit provides large currents and remains mobile, usually 3000 to 10000 amperes AC and HWDC current.

Stationary equipment

Hand operated, stationary, horizontal wet method is widely used for small manufactured parts. Stationary equipment normally contains a built-in tank with a pump which agitates the wet particle bath and pumps inspection fluid through a hand held hose for application to the test object. A part is clamped within the magnetizing coil between the copper contact faces of the head and tail stock. At the operator's option the parts can be magnetized circularly with current

between the heads or longitudinally with current through the coil or both if desired. While the part is magnetized, the operator applies the liquid inspection medium and then views the surface for indications. Most units are provided with inspection hood and black lights so that the fluorescent magnetic particle inspection medium can be used. Stationary units are generally designed to operate from a 440V three phase alternating current source and to deliver alternating or rectified magnetizing currents. Current control is infinitely variable. For magnetic particle testing of large complex castings, welded structure or plate, overall magnetization with high magnetizing current is usually employed. The currents up to 12 000 amperes is required for such application. Figure 8.4 is a modern bench type stationary unit.

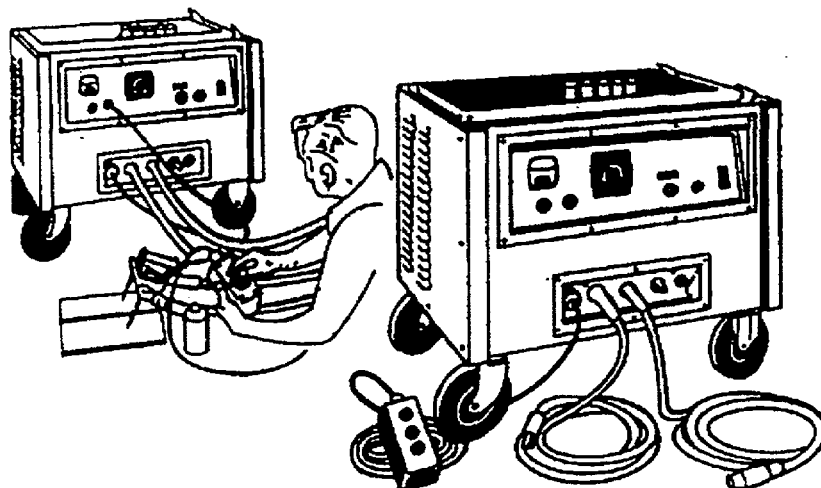

Figure 8.3: Standard mobile unit.

Present day stationary units perform multidirectional magnetization through two to three magnetizing circuits, making it possible to detect all discontinuities in all directions. There are two basic types of electric current, namely, alternating current (AC) and direct current (DC). The other forms of magnetizing current is half wave rectified AC, full wave rectified AC and rectified three phase AC. Use of rectifiers help in obtaining either form of the rectified AC. Since the magnitude of the rectified DC is varying and also in the absence of use of filters would contain small value AC components thus the DC is in a way pulsating. The wave forms of all types of current are shown in Figure 4.5 (a–e).

8.1.4. Types of current and concepts of testing capacity

Alternating current (AC)

The use of magnetizing (AC) current is made for surface open discontinuities. The alternating current and its magnetic field produced, tend to remain confined to the surface only due to the phenomena known as skin effect. Thus use of alternating current is not recommended for detection of sub-surface defects. The AC induced fields help in better particles mobility and a better indication of discontinuities.

Direct current (DC) or half wave rectified AC (HWDC)

Direct current produce mores deep penetrating fields than AC and thus is more sensitive for sub-surface discontinuities. Half wave rectified AC single phase current produces fields for

maximum sensitivity of inspection. This is so because the pulsating field increases the particle mobility and enables particles to line up more readily in the leakage fields. The pulse peaks produce a stronger magnetizing force.

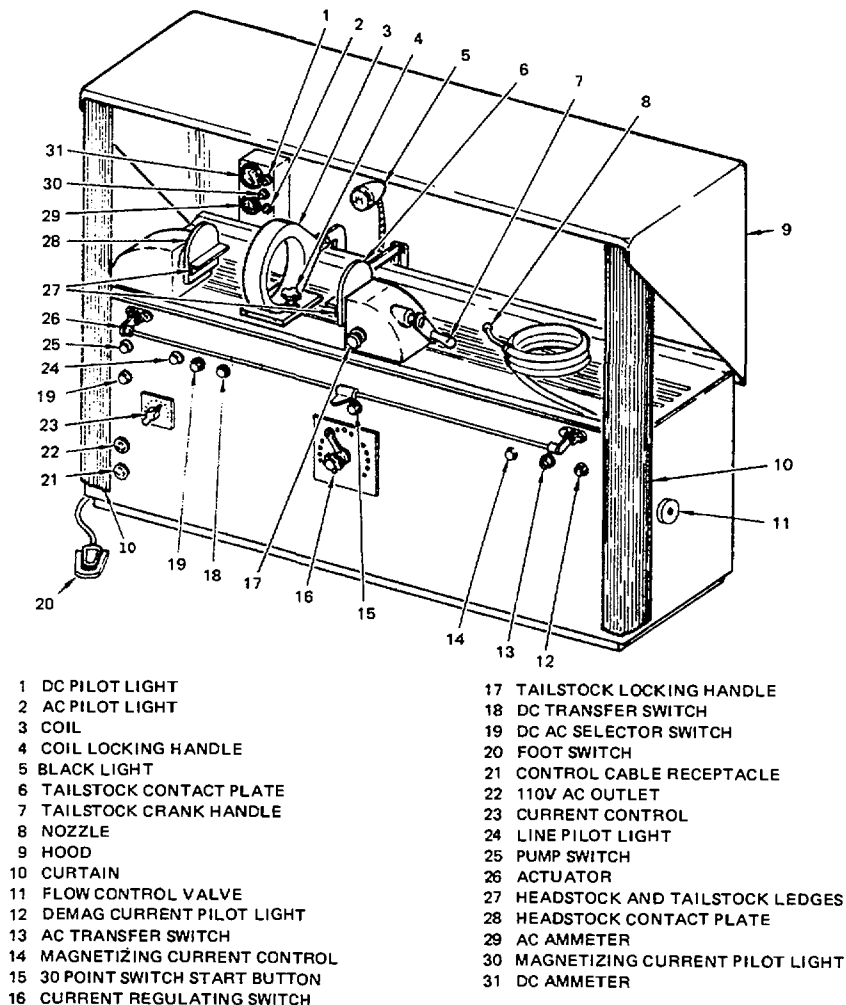

Figure 8.4: Wet horizontal magnetic particle test equipment.

Full wave rectified single phase AC

The use of pulsating unidirectional current is sometimes made for magnetic particle testing. In general it possesses no advantage over half wave and is not as satisfactory as three phase rectified current when straight DC is required because of its high ripple. It also draws a higher current from the AC lines than does half wave for a given magnetizing effect, which is a distinct disadvantage.

Three phase rectified AC

In the three phase AC, there are three separate currents following sine wave curves each at 50 or 60 cycles per second but with peaks of their individual curves 1/3 rd of a cycle apart Figure 8.5 e. When three phase alternating current is rectified, the full wave rectification system is used, the result is DC with very little pulsations. For magnetic particle testing purposes, it has all the

effects which are required when DC magnetization is indicated i.e. deeper penetration and more favourable power transmission and line load characteristics.

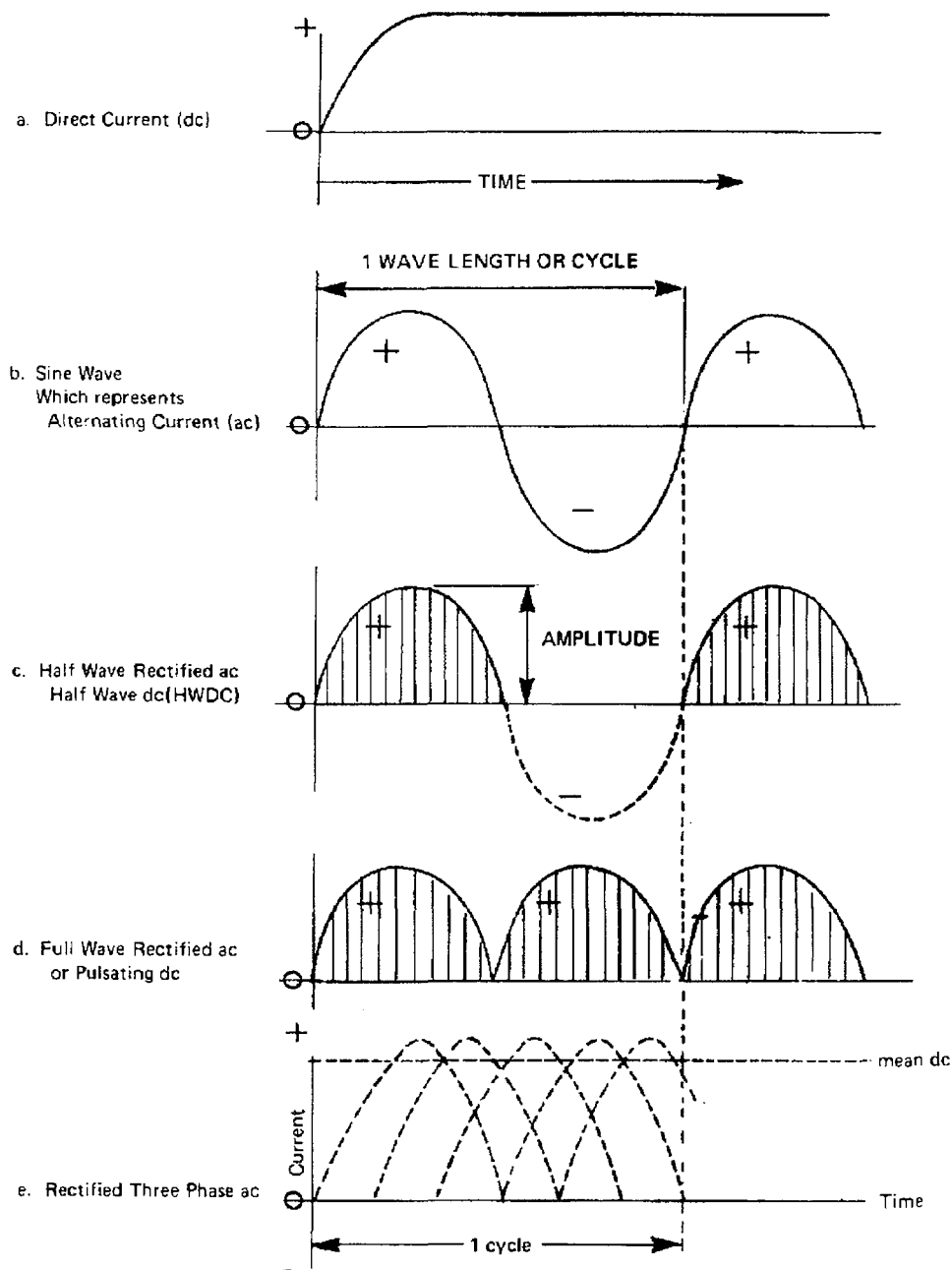

Figure 8.5: Direct and alternating currents.

Penetration characteristics

The AC method is more sensitive than DC or HWDC, in showing surface discontinuities. Figure 8.6 compares the abilities of various methods to detect subsurface discontinuities. The graph plots amperage against depth of discontinuity. This experiment was performed using the test specimen shown at the lower right in Figure 8.6. The lowest amperage that gave a minimum threshold indication at various discontinuity depths was recorded.

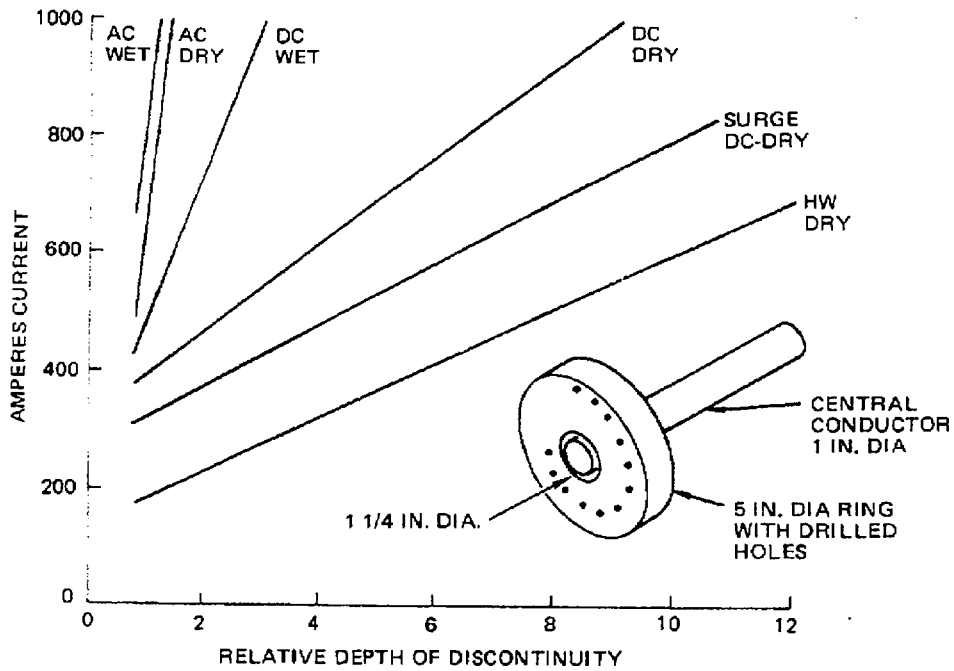

Figure 8.6: Threshold sensitivities of various test methods.

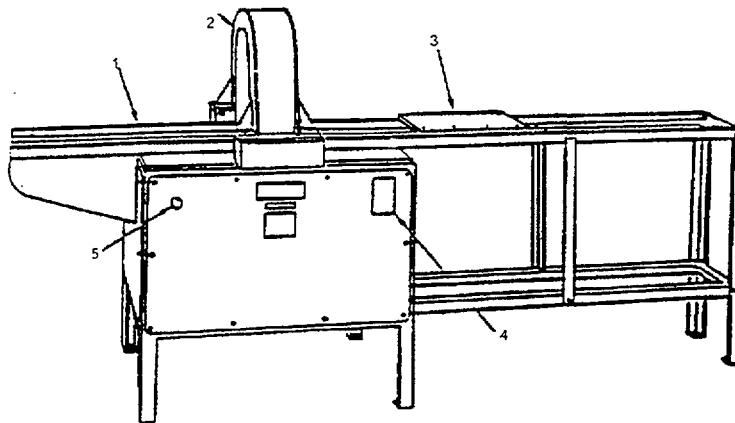

Figure 8.7: Typical demagnetization unit (1. Trak, 2. Demagnetization coil, 3. Movable carriage, 4. Timer and switch, 5. Indicator lamp).

8.1.5. Demagnetization equipment

The need for having demagnetizer equipment is vital for removing the residual magnetism parts, in particular those where such a field is going to affect their serviceability, further machining and inspection. On semi-automatic equipment the demagnetizer is commonly integral with the test equipment and automatically demagnetizes parts as they pass by on the conveyor. They can be hand operated or automatic and can operate intermittently or continuously. The demagnetizer is chosen on the basis of part size, complexity of shape, retentivity of the test objects and level of demagnetization required. It is advisable to consider the requirement of such a demagnetizer to be incorporated in the magnetic particle test equipment at the time of its purchase.

Demagnetization with alternating current

A common method of demagnetizing small to moderate-size parts is by passing them through a coil through which alternating current at line frequency is passing (usually 50 to 60 Hz). Alternatively, the 60-Hz alternating current is passed through a coil with the part inside the coil, and the current gradually reduced to zero. In the first method, reduction of the strength of the reversing field is obtained by axially withdrawing the part from the coil (or the coil from the part) and for some distance beyond the end of the coil (or part) along that axial line. In the second method, gradual decay of the current in the coil accomplishes the same result. Passing a part through an alternating current coil is usually the faster and more preferred method. Small parts should not be loaded into baskets and the baskets passed through the coil as a unit, because alternating current will not penetrate into such a mass of parts, and only a few parts on the outer edges will be demagnetized, and these possibly only partly demagnetized. Small parts can be demagnetized in multiple lots only if they are placed in a single layer on a tray that holds them apart and in a fixed position with their long axes parallel to the axis of the coil. Large parts are not effectively demagnetized with 60-Hz alternating current, because of its inability to penetrate. Alternating current with 25-Hz frequency is more effective.

Machines that provide decaying alternating current have a built-in means for automatically reducing the alternating current to zero by the use of step-down switches, variable transformers. When decaying alternating current is used, the current may be passed directly through the part instead of through a coil. Passing the current through the part is more effective on long circularly magnetized parts than the coil method, but does not overcome the lack of penetration because of the skin effect, unless frequencies much lower than 60 Hz are used.

Demagnetization with direct current

Methods of demagnetizing with direct current are essentially identical in principle to the alternating current methods just described. By using reversing and decreasing direct current, low frequency reversals are possible, with resulting more complete penetration of even large cross sections. One reversal per second is a frequency commonly used. It is a successful means of removing circular magnetic fields especially when the current is passed directly through the part, and can be used to demagnetize large parts. When a coil is magnetized using direct current at one reversal per second, the part remains in the coil for the duration of the entire cycle.

Oscillating circuits

Oscillating circuits are a means of obtaining a reversing decaying current for demagnetizing purposes. By connecting a large capacitance of the correct value across the demagnetizing coil, the coil becomes part of an oscillatory circuit. The coil is energized with direct current and when the source of current is cut off, the resonant resistance-inductance-capacitance circuit oscillates at its own resonant frequency, and the current gradually diminishes to zero.

Yokes

Either direct or alternating current yokes, provide a portable means for demagnetizing parts. The space between the poles of the yoke should be such that the parts to be demagnetized will pass between them as snugly as possible. With alternating current flowing in the coil of the yoke, parts are passed between the poles and withdrawn. Yokes can be used on large parts for local demagnetization by placing the poles on the surface, moving them around the area and then withdrawing the yoke while it is still energized. Yokes using low frequency reversing direct current, instead of alternating current, are more effective in penetrating larger cross sections.

Applicability of demagnetizing methods, based on part size, metal hardness, and production rate, is given in Table 8.1.

TABLE 8.1: APPLICABILITY OF DEMAGNETIZING METHODS ON THE BASIS OF PART SIZE, METAL HARDNESS, AND PRODUCTION RATE(A)

Method	Part size			Metal hardness			Production rate		
	Small	Med.	Large	Soft	Med.	Hard	Low	Med.	High
Coil, 60-Hz AC	A	A	N	A	A	N	A	A	A
Coil, DC, 30-point reversing step-down	N	A	A	A	A	A	A	N	N
Through-current, AC, 30-point step-down	N	A	A	A	A	A	A	A	N
Through-current, AC, reactor decay	N	A	A	A	A	A	A	A	N
Through-current, DC, 30-point reversing step-down	N	A	A	A	A	A	A	N	N
Yoke, AC	A	(b)	N	A	A	N	A	N	N
Yoke, reversing DC	A	(b)	N	A	A	A	A	N	N

(a) A = applicable; N = not applicable. (b) Used for local areas only

8.1.6. Maintenance and use of the equipment

Some critical maintenance procedures are required for mobile magnetic particle testing systems. For instance, the cooling intake of the unit must be kept clean to permit the free flow of the air, especially if the unit is moved into a dirty testing environment. Prod tips are another source of concern. They may become corroded or burned, hindering a good contact with the test object. Defective prod tips can produce arc burns and these are proven source of cracking. Similarly, clamps should have good copper mesh gripping points. Frayed cables and continuous overheating decrease the conductivity of the cable. This produces heat, increases resistance and reduces the amperage available for testing. Connectors and cable joints with the test part should be tight and solid to help prevent overheating.

8.2. Accessories

8.2.1. Contact points

The number of accessories available for use in magnetic particle testing is extensive. Some are available from the manufacturers of magnetic particle equipment; others are made up for specific purposes. The need for accessories usually depends on the type and method of application of the test selected. An accessory may speed up a procedure but, if its use in any way impairs the quality of the test, the accessory defeats its purpose. Table 8.2 illustrates some frequently used accessories and their application. In Figure 8.8 some of the types discussed above are shown.

TABLE 8.2: ACCESSORIES AND THEIR USE

Cables	Used with mobile or portable magnetic particle equipment to carry the current to prod or solenoid.
Contact heads	Electrode assembly used to clamp and support a part to facilitate passage of current through the part for circular magnetization.
Contact clamps	Used instead of prods to facilitate good contact with article or when one-man operation is required.
Contact blocks	Used to facilitate cable connection from stationary equipment for external use of prods or coils.
Demagnetizing unit	Used to demagnetize ferrous metals containing residual magnetism.
Field indicator	Used in measuring residual magnetism in an article.
Leeches	Used as prods or clamps.
Liquid applicator	Used in applying fluorescent or non-fluorescent test medium: can be either manual, electric, or air operated.
Mesh/Contact pad	Used between contact points and article tested to avoid sparking and burns.
Powder applicator	Used to apply magnetic particle powder to the test area: can be a powder-puff, or powder blower, hand-operated, electric, or air.
Prods	Used for magnetizing of welds, sheet, or plate.

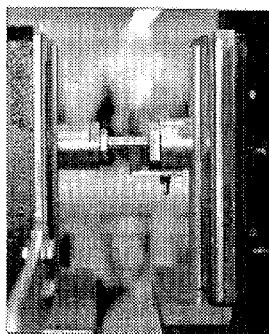

Auxiliary Adapters

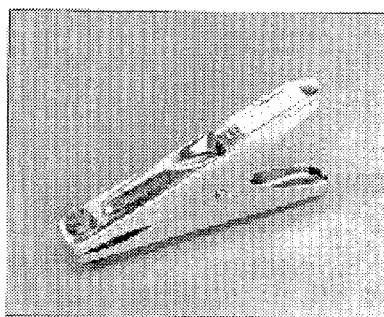

Contact Clamps

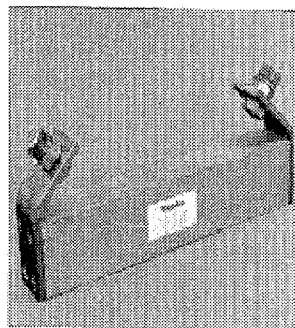

Contact Block

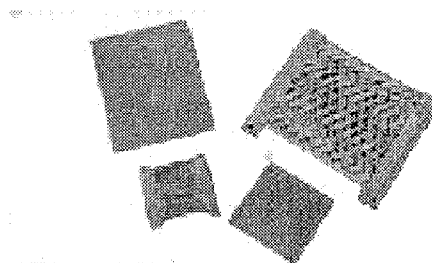

Contact Pads

Figure 8.8: Accessories.

8.2.2. Vessels for checking bath concentration

The bath used with the wet method of magnetic particle testing consists of a liquid vehicle in which the particles of known concentrations are suspended. The required test sensitivity is achieved only for correct concentration. Too light a concentration leads to very light indication of discontinuities; too heavy a concentration results in too much overall coverage, which may mask or cause incorrect interpretation of discontinuity indication. The vessel used for knowing the concentration is a graduated glass flask. Its stem measures up to 1.5 mL in 0.1 mL graduations. The suspension is agitated for 30 minutes to ensure even distribution of particles in the vehicle. Then 100 cc (mL) of bath is pumped through the hose nozzle into this pear shaped centrifuge tube and allowed to settle for 30 minutes. The amount of particles (measure in cc or mL) settling in the bottom of the centrifuge indicates the concentration of particles in the bath Figure 8.9.

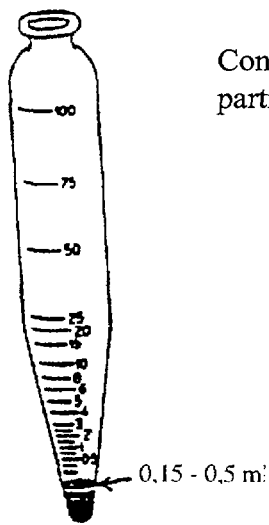

Concentration for wet suspension (fluorescent) 0.1–0.5 mL of particles/100 mL or 100 cc.

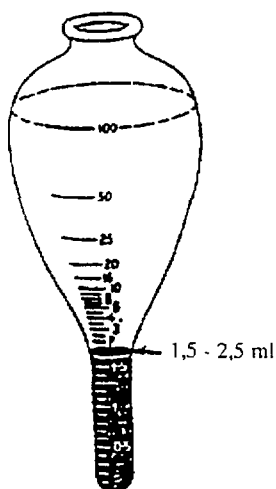

Concentration for wet suspension (visible) 0.0–2.4 mL of particles/100 mL or 100 cc.

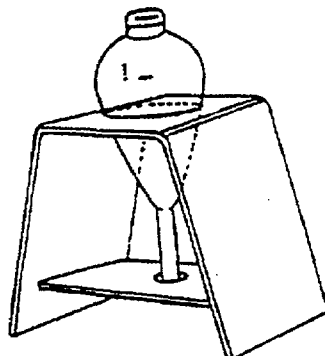

Figure 8.9: Vessels for checking bath concentration.

8.2.3. Field indicator (berthold test piece)

A magnetic field indicator is used for checking the adequacy and direction of the part magnetization. A suitable and sufficient flux or field strength is indicated when a clearly defined lines of magnetic particles forms across the copper face of the indicator. The construction of the indicator is as follows. The test piece consists of a remanence free shielding ring into which an iron cylinder sectioned into four quarters is placed. The iron cylinder is covered by a thin brass plate, which can be varied in distance to and from the work piece.

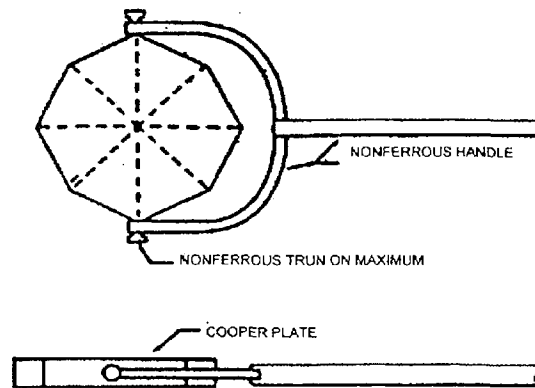

Figure 8.10: Field indicator (berthold test piece).

8.2.4. Calibration pieces (JIS)

JIS (Japanese Standard Institute) has mentioned the standard reference block type A, and C in their specification G 0565-1982. Their use is made for examining the performance of apparatus, magnetic particles and suspensions. It is also used for measurement of strength and direction of the effective field on the surface of the test article. Figure 8.11 illustrates type A, JIS standard block circular and linear. Type B is a reference standard similar to annular ring.

JIS type C standard block are similar to type A, and are used in situation where the application of the latter is difficult for dimensional reasons such as examining the narrow area.

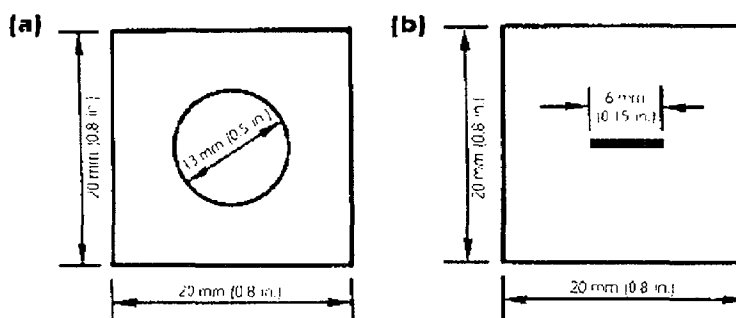

Figure 8.11: Japanese type A standard test shims, (a) circular and (b) linear.

TABLE 8.3: TYPE A STANDARD TEST BLOCK.

Designation		Quality of material	
A1-7/50	A1-15/50	JIS C 2504-class 1, annealed (kept in an inert gas atmosphere at 600°C	
A1-15/100	A1-30/100	for 1 hour and slowly cooled in the atmosphere down to 100°C or under)	
A2-7/50	A2-15/50	A2-30/50	JIS C 2504-Class 1,
A2-15/100	A2-30/100	A2-60/100	as cold-rolled

Remarks:

- In the designation, the figure of numerator indicates the depth of artificial flaw and that of denominator the thickness of plate. Dimensions are in micrometre.
- The designation of the block shall be examples as shown below, where the shapes of artificial flaw are given in parenthesis. Examples: A1-7/50 (circular), A2-15/50 (linear).

8.2.5. Magnetic field measurement equipment (gauss meter)

Leakage field intensities can be measured quantitatively or by employing comparative methods.

Gauss meter

Gauss meter measures the flux density inside a part. The Gauss meter is an instrument that measures the total change of flux through a coil, independent of the rate of change. It consists of a coil connected to a ballistic galvanometer through suitable long time circuitry. When the magnetic flux through the coil changes either by moving the coil or the part or otherwise varying the field in the part by some means, the needle of the galvanometer swings and indicates the amount of change. The change in the flux may be either in positive or the negative direction. Knowing the area of the coil, the average flux density within the coil can be calculated. Figure 8.12 illustrates an arrangement for measuring flux in bearing race.

Generally, the coil should be made to fit closely; however, little error is introduced by the coil fit, unless the coil fit is very poor. The change in flux is obtained by first setting the meter to zero with the magnetizing current off, and then noting the reading when the current is turned on. The value of flux is obtained by the formula:

$$\text{Flux} = K \times \text{Deflection/Number of turns} = 10000 \times D/N \quad (1)$$

where, K is a constant and as an example is 10000.

D is the deflection read on the galvanometer.

N is the number of turns in the coil.

Flux density is measured, then, by dividing the value obtained with the area of coil.

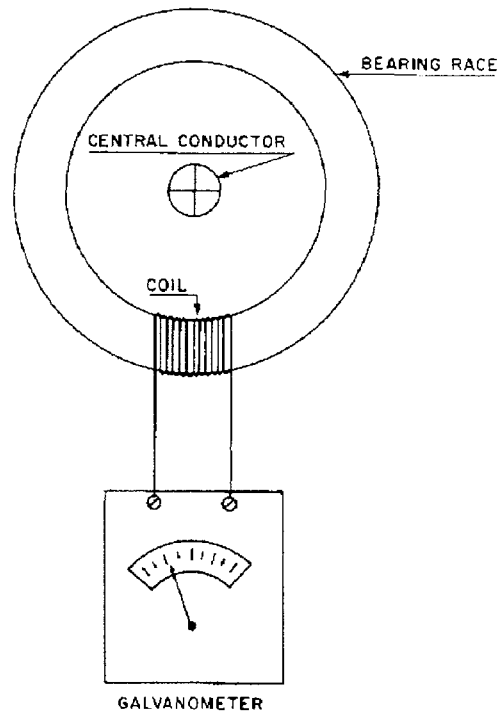

Figure 8.12: Gauss meter to measure the flux in a bearing race.

8.2.6. Ultraviolet lamps

The need of using ultraviolet lamps arises during inspection with fluorescent magnetic powder. The black light equipment usually consists of current regulating transformer, a mercury arc bulb, and filter. The bulb and filter are contained in a reflector lamp unit and the transformer housed separately. For correct result the lamp should produce an intensity of $800 \mu\text{w}/\text{cm}^2$ in a 3 inch (75 mm) circle, 15 inches (375 mm) distance from the front surface of the filter.

The deep red purple filter is designed to pass only those wave lengths of light which shall activate the fluorescent material. At least five minutes warm up time is required to reach the required arc temperature. The mercury vapour lamps are gaseous discharge devices in which an electric arc takes place in a controlled atmosphere and emits light whose characteristics depend on the nature of that atmosphere. The construction of a mercury vapour bulb is shown in the Figure 8.13.

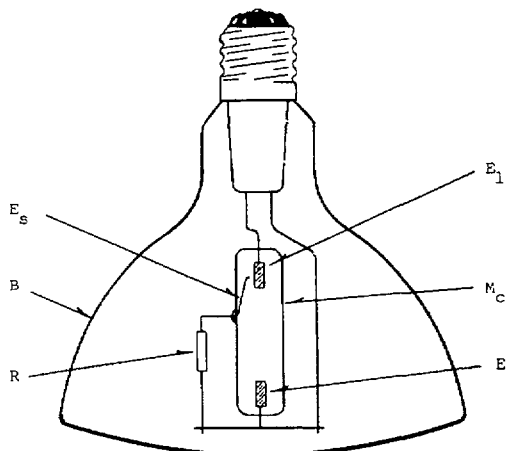

Figure 8.13: Construction drawing of the high pressure mercury arc lamp.

Starting up of mercury vapour arc lamps

When the lamp is first turned on the mercury in the cartridge (Mc) is not in vapour form but is condensed in droplets on the inside of the tube. To facilitate starting a small amount of neon gas is incorporated into the cartridge, and a starting electrode (ES) is sealed through one end of the tube near one of the main electrodes. When a voltage is first applied a discharge will take place from the starting electrode through the neon. The glow discharge carries a small current, limited by the protective resistor R, but sufficient to vapourize and ionize mercury and eventually cause an arc to strike between the main electrodes. The heating and ionization process requires from 5 to 15 min of starting time when the lamp is first turned on.

Tubular fluorescent cold discharge black light source

These are standard fluorescent bulbs that come in sizes from 2 to 60 input watt and over. These cold discharge tubular lamps contain low pressure mercury vapour glow discharges. Their primary radiation is hard ultraviolet of 253.7 nm (2537 Å) wavelength. This ultraviolet light excites the phosphor coated on the inside of the tube and on activation emits black light with a range of 320 to 440 nm, peaking at 360 nm.

These sources of light produce lower light density than mercury vapour bulb and are thus not suitable for use in critical fluorescent penetrant inspection. However they are the practical sources for battery powered, portable black light. Unlike mercury vapour arc bulbs, these fluorescent black light sources attain full power in few seconds.

Measurement of black light intensity

Present day, the specially designed meters calibrated in watts per square metre or microwatt per square centimetre are required to measure the intensity of black light sources. An example of such a meter is J-221, which measures long wave ultraviolet, shown in Figure 8.14. The J-221 meter scale extends to 5000 microwatt per centimetre square. With a multiplier screen the scale is extended by five times.

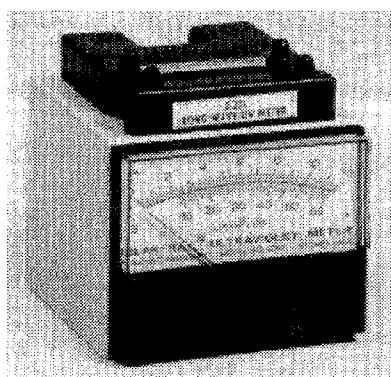

Figure 8.14: Meters used to measure ultraviolet long wave irradiance.

The intensity readings are taken directly by illuminating the surface with black light source and meter placed at the location of interest. The readings are normally taken with sources of light placed at a distance of 15 inch (40 cm) or others as specified by a referencing code.

8.2.7. Coloured and fluorescent powders

The particles used in either dry or wet magnetic particle examination techniques are finely divided ferromagnetic materials which have been treated to impart colour (fluorescent and non-fluorescent) in order to make them highly visible (contrasting) against the background of the surfaces being examined.

The dry magnetic particle powder is made in almost any colour, the most frequent employed colours are light grey, black, red, or yellow. Fluorescent dry powders are also available, but their use is limited for economy reasons. They require a black light source and means to darken the work area.

Fluorescent wet method particles glow as bright yellow green when viewed under black light. Non fluorescent particles are usually black or reddish brown, although other colours are available. Since the contrast (sensitivity) is invariably higher with fluorescent materials, these are utilized in most wet process examinations.

8.2.8. Colour for increasing contrast

Choice of selecting dry powder of a particular colour is made to achieve maximum detection sensitivity or contrast. The brightness of the fluorescent magnetic powder should be maintained at the established level so as the indication and background brightness can be kept at a constant level. Excessive increase in brightness can cause high background fluorescence which may result in difficulty in indication interpretation, while inadequate brightness can result in indications being undetected. Sometimes a thin coating of contrasting paint is applied on the test surface to increase the visibility of indications if present.

8.2.9. Morphology of the particles

The morphology of the particles is the study of different forms of the particles regarding their shape, size, colour (visible and fluorescent), magnetic behaviour and applicability etc. The magnetic particles generally have high permeability to allow the ease of magnetizing and attraction to the discontinuity and low retentivity so they will not be attracted (magnetic agglomeration) to each other. These particles are designed for use either as a free flowing dry powder, or for suspension at a given concentration in a suitable liquid medium.

The indicative power of magnetic powders is mainly determined by the following properties of the powder:

- Magnetic properties.
- Visibility properties.
- Mobility properties.
- Geometric properties.

Magnetic properties

The particles of the testing medium must possess two important magnetic properties: high permeability and low retentivity. Permeability is defined as the degree of ease with which a particle is magnetized; retentivity, as that property which causes particles to retain, to a greater or lesser degree, a certain amount of residual magnetism. Particles incorporating high permeability and low retentivity are strongly attracted to leakage fields, but do not remain magnetized when removed from the influence of the magnetic field.

Geometric properties

Grain size of the particles used should correspond approximately to the gap of the crack to be identified. Coarse grains are either not held in place because of their weight, or are more easily rinsed away by the carrier liquid (wet method). If the particles are too small, the formation of bridges over the gaps of cracks becomes difficult. In practice, cracks may be expected which have different gaps. Thus it is more practicable to use a mixture of powders of different grain sizes.

In general, the dry powder method is carried out using average grain size of between 60 to 300 microns, whereas the wet method is usually carried out using grains of smaller sizes (a few microns), in order to be able to identify very fine surface cracks.

The spherical-shaped particle offers a high degree of mobility but is not so strongly attracted to leakage fields because of its shape. On the other hand, the long, slender, jagged particle is strongly attracted to leakage fields but has low mobility. A multi-facet, nugget-shaped particle is a good compromise in that it reasonably combines the optimum qualities of the other two shapes. Particle size is an important consideration. Small particles are required to detect weak leakage fields, larger sizes are used only when specifications allow their use, since a weak leakage field is unable to hold a large particle, but is able to retain one of smaller size. Thus, dry powder magnetic particles are made up in a wide range of sizes — though all will pass through a 100 mesh screen.

In the wet method, oxides of iron are used as magnetic particles. They are of lower permeability than the metallic dry particles and have neither the most desirable shape nor variety of sizes. They are extremely fine in size so that they will remain in suspension to maintain mobility as long as possible before settling out. Even so, the bath must be continually agitated to maintain the particles in suspension. When using fluorescing magnetic powders, one usually chooses magnetic particles which have a slightly rougher surface finish. This helps increase adhesion, and thus the life of the fluorescent coating.

Visibility properties

For proper visibility, colour contrast of powders against surfaces on which they are used is important. Good lighting is essential. Iron oxides are red-black, carbonyl iron powder has a grey colour. In addition to the colour contrast, the brightness contrast (luminance difference) is of extreme importance. This requirement for brightness difference is met particularly well by fluorescent magnetic powders. The individual magnetic powder particles are given a coating of some fluorescent material. When excited by ultraviolet light, the substance gives off a yellow-green or orange-coloured fluorescence.

Mobility properties

When the particles are applied to a test specimen they must be applied in such a way that they are free to form a pattern or indication in the presence of leakage fields.

- (a) In the dry method, mobility is obtained by dusting or blowing the particles over the surface of the article. The ideal procedure, from the point of mobility, is to float a cloud of particles with very low velocity up to the surface being tested. This condition is obtainable only with special equipment. The floating action permits the leakage field at the discontinuity to catch and hold some particles as they move by. Mobility is also obtained by vibrating the article after the particles have been applied. Since the alternating field's influence causes the particles to "dance", AC is used advantageously to provide mobility.

- (b) The principal advantage of the wet method is the excellent mobility of the suspended particles. A low viscosity liquid is used so that the mobility of the suspended particles is not impeded by the liquid.

Methods of application

Dry magnetic particles are commonly applied from shaker cans or bulbs. This method is the simplest, but not necessarily the best. Automatic particle- blowing equipment is usually economical in its use of particles and, in most instances, is the most satisfactory way of floating dry particles to the test surface with minimum velocity. Wet suspensions are caused to flow over the surface to be examined, or the article is immersed in a bath of the suspension. Flow application is usually used with continuous magnetic particle testing, and the immersion bath with residual testing.

8.3. Selection of equipment appropriate to the nature of the test

The selection of the equipment is one of the very important operating decisions for any technique. This decision depends on the size, shape, number and variety of the parts to be tested. For production testing of many parts which are relatively small, but not necessarily identical in shape, a bench type unit with clamping head contacts for circular magnetization, and a built-in coil for longitudinal magnetization is commonly used. In such applications wet continuous method is generally selected, although some dry powder units of this type have been in service.

In situations where the parts are large, portable units using prods or c-clamp contacts and hand-wrapped coils may be most convenient. Half-wave and dry powder are often used with such units as in the inspection of welds and large castings.

In some cases no-power is available to operate magnetizing equipment in the area where the inspection must be carried out, or the nature of the inspection does not justify the purchase of more expensive equipment. In such cases permanent magnet yokes may be used; or electromagnet yokes operated either by AC or rectified AC if some current source can be had. Yokes using automobile or other storage batteries as a source of energizing current are another solution of the no-power problem. In explosive areas, permanent magnet yokes furnish a safe way to secure local magnetization for maintenance inspection. Inspection with these devices is usually limited to spot checking or occasional testing of miscellaneous parts.

8.4. Special equipment

Special purpose units may be manual, automatic, or semi-automatic machines. They are designed for one specific part or class of items. The magnetizing system and the handling devices are designed for specific configurations. The magnetizing features are designed to minimize handling of large or heavy parts and provide for sufficient localized flux density to assure that critical discontinuities of certain types and sizes are detected. Specialized machines can be designed to control the method and reproducibility level of the test at specific quality levels.

8.4.1. Portable equipment

The most modern of the series of portable units is the power back shown in Figure 8.15. This type of unit delivers from 4000 to 6000 amps output of magnetizing current, either AC or half wave rectified DC with infinitely variable current control. The current "dial amps" system automatically delivers the selected amount of current to the external magnetizing circuit and automatically compensates for variations in load impedance and line fluctuations.

8.4.2. Stationary installations

The stationary magnetizing (special unit) may or may not always be complicated or expensive. Sometimes a special accessory can be built for a standard unit and do the job adequately. In other cases, of course when all processing and handling is automatically controlled and sequenced, the unit is necessarily more complex and more costly. Figure 8.16 given below shows a special circuit for crankshaft inspection which is a standard unit equipped with special fixtures to process crankshafts automatically.

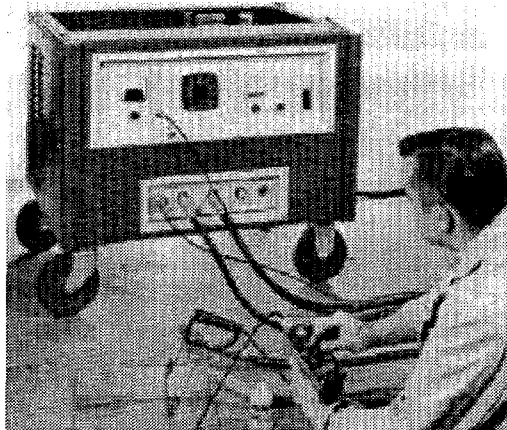

Figure 8.15: A modern portable magnetizing unit.

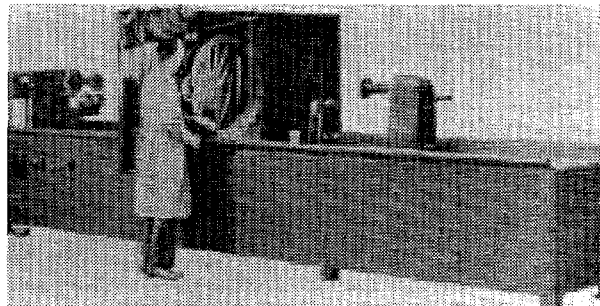

Figure 8.16: Largest bench-type magnetizing unit for large diesel crankshafts.

8.4.3. Automated equipment

Automatic magnetic particle units are special purpose machines designed for the inspection of items that are all of the same configuration. Some automatic units can be adjusted to handle similar items of different dimensions. One of the most important reasons for using an automatic machine is that it will provide the correct inspection in a reproducible fashion.

Before an automatic machine is ordered, the configuration of the part should be in a final design stage. The type of material and the critical high stress areas must be known and the manufacturing method determined. A prototype part will be needed for check-out of the machine.

The visual inspection for magnetic particle indications obtained with automatic machines is still principally accomplished by inspectors. There are some machines that have been developed for special applications that provide fully automated inspections, including analyses of the

detected indications. These systems used different lighting and viewing systems that incorporate photo-cells connected to scanning mirrors. Some scanners use a laser for illumination where very small discontinuities are to be detected.

Maintenance of automatic machines is an important consideration. The magnetizing units are quite rugged, but automatic mechanisms require specialized maintenance care. If at all possible, an in-house maintenance capability is desirable since the automatic system is usually a one-of-a kind machine. An automatic system is required upon to handle high production; when it is inoperative, total production capability can be lost.

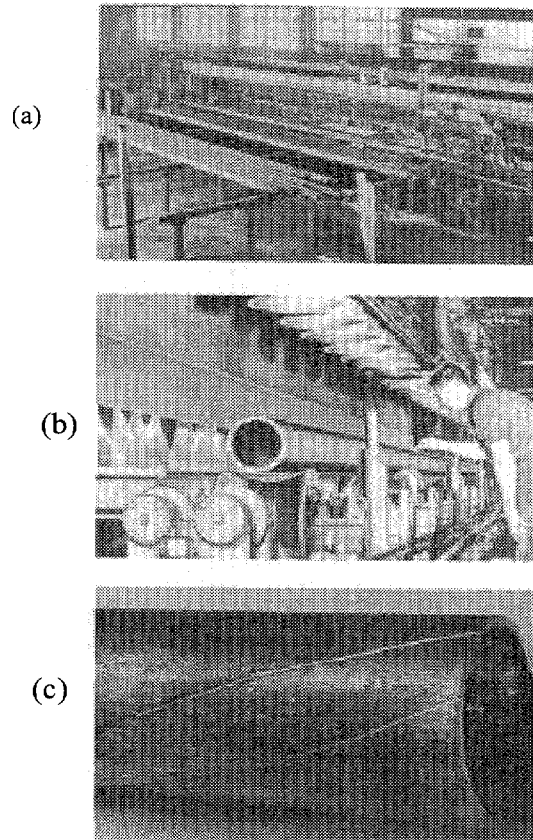

Figure 8.17: Automatic system for magnetic particle testing of seamless tubing: (a) loading side; (b) inspection station; and (c) example of fluorescent particle indication of spiral seams.

9. CODES, STANDARDS, SPECIFICATIONS AND PROCEDURES (MT)

9.1. Interpretation of procedures for the application of tests using various techniques

Magnetic particle testing is performed in accordance with a written procedure. Many large companies that make extensive use of magnetic particle testing have prepared their own versions of the procedures that are to be used in their operations. These are usually rather broad in their approach, except that they may be limited to those specific procedures applicable to their product. These procedures are normally peculiar to a particular technique and equipment. Similarly, many technical societies have prepared broad procedural guides for the use of their members who wish to learn about or use magnetic particle testing method. Some of the organizations such as American Society of the Mechanical Engineers (ASME), American Welding Society (AWS), American Society for Testing and Materials (ASTM), the Society of Automotive Engineers etc. have developed such procedures. These procedures, if referenced by some referencing code, become mandatory and all the stated requirements have to be met. The written procedure should include at least the following elements, either directly or indirectly or by reference to the applicable documents.

- The procedure should be on company letterhead so as to clearly demonstrate its origin.
- The procedure should have its own code number and the latest issue number.
- Identification of the test objects to which the procedure applies including material and alloy.
- Areas of the test object to be examined.
- Direction of magnetization to be used, the order in which they are applied and any demagnetization procedures used between shots.
- Methods of establishing magnetization (prods, yoke, cable wrap, multidirectional system).
- The type and level of magnetizing current (alternating current, half wave direct current or full wave direct current) and the equipment used.
- The current level or the number of ampere turns used and the duration of its application.
- Test object preparation before testing.
- Type of magnetic particle material (dry or wet, visible or fluorescent) and the method and equipment used for its application.
- Type of records and method of marking objects after testing.
- Acceptance criteria and disposition of objects after testing.
- Post test demagnetization and cleaning requirements.
- Sequence of magnetic particle testing as related to manufacturing process operations.

All valid indications formed by magnetic particle examination are the result of magnetic flux leakage fields. Indications may be relevant or non-relevant. Indications caused by particles being held by non-magnetic forces are false: examples include particles lying in the depression at the side of a weld, or particles wedged into rust or scale on the surface.

9.2. Composition of the procedures including instructions for various methods and techniques

9.2.1. *Various materials and shapes*

The magnetic particle examination method is applied to detect cracks and other discontinuities on or near the surface of ferromagnetic materials. The sensitivity is greatest for surface discontinuities and diminishes rapidly with increasing depth of surface discontinuities below the surface. Typical types of discontinuities that can be detected by this method are cracks, laps, seams, cold shuts, and laminations. In principle, this method involves magnetizing an area to be examined and applying ferromagnetic particles (the examination medium) to the surface. The particles will form patterns on the surface where cracks and other discontinuities cause distortions in the normal magnetic field. These patterns are usually characteristic of the type of discontinuity that is detected. Whichever technique is used to produce the magnetic flux in the part, maximum sensitivity will be to linear discontinuities oriented perpendicular to the lines of flux. For optimum effectiveness in detecting all types of discontinuities, each area should be examined at least twice, with the lines of flux during one examination approximately perpendicular to the lines of flux during the other. The shape and material of the test job has great influence on the choice of a particular technique. The method works best on steels and alloys that have high permeability. Discontinuities lying wholly below the surface are more likely to be located in soft steels having high permeability than hardened steels and alloys which in nearly all cases have low permeability. In case of grey or malleable iron castings, surface cracks are easily located. The method also works well on metallic nickel and cobalt. On the other hand, stainless steel and other alloys which are in austenitic state cannot be tested with magnetic particles at all, since iron in this state is non magnetic.

The use of any technique produces either a circular field, longitudinal or combination of both in quick successions. For creating circular field, use of either prods, direct contact passage of current into the job or by the conductor passed through the bore of circular job is made. The value of current required is calculated on the basis of the outer diameter of the jobs. But in case of jobs with shapes other than true symmetrically circular, this value is taken as the greatest cross-sectional diagonals in plane perpendicular to the current flow.

For longitudinal magnetization by coil of a bar with uniform cross section, flux density is approximately uniform over the cross section at any point except at each end of the bar. However, if there is an upset portion, along the length of the bar, the field tends to flow out into the upset portion but does not do so uniformly. When attempting to magnetize a part of irregular shape, the analysis of the probable path of field should be made. Sometimes separate coil magnetizations must be applied to various projections of the test part to ensure proper field direction at all locations. A satisfactory procedure can usually be worked out for the most complicated shapes after some experimentation.

9.2.2. *Selection of the equipment*

The decision on the selection of the equipment depends on size, shape, number and variety of parts to be tested. For production testing of numerous parts which are relatively small, use of horizontal bench type stationary units with clamping head contacts for circular magnetization and a built-in movable coil for longitudinal magnetization is commonly made. If the parts are large, portable units using prods or C-clamp contacts and hand wrapped coils may be a convenient choice.

9.2.3. Type of current

The choice is dictated by the location of defects, whether they are open to the surface of the part or located wholly below the surface. Choice of current lies between AC and some form of DC (Full wave rectified or half wave rectified (HWDC)). For surface open defects, AC is the first choice whereas for deeper penetration ability of straight DC or rectified half wave and full wave, the use of later is made. Thus the magnetizing equipment to be used should also have the ability to generate the type of current desired.

9.2.4. Selection of inspection media

The selection has to be decided between dry and wet method and secondarily among the various colours that are available, including fluorescent particles. This decision is principally influenced by the following considerations:

- Whether the defect sought is on the surface or wholly below the surface: For deep-lying defects dry powder is more sensitive.
- The size of the defect, if on the surface: The wet method is usually best for very fine and shallow defects.
- Convenience: Dry powder with a portable half wave rectified unit, for instance, is easy to use for occasionally large parts in the shop or foundry, or for field inspection work.

9.2.5. Field detection

It is very essential to ascertain during magnetic particle inspection the adequacy of field strength and direction. This is an essential requirement for producing a good indication of existing defects. It is thus very important for the operator to ensure that a field of sufficient intensity and of desired direction exists within the magnetized job. Flux meters help in determining experimentally the flux density within the part. Similarly other meters are available which measure the existing flux on a point just above the part. Use of Berthold field indicator is very conveniently made by placing them on the job at the site of interest during magnetization. The formation of the pattern on the face of the indicator shall ensure the adequacy of the existing field strength and direction.

9.2.6. Intensity

For achieving the desired level of magnetic field intensity during the use of different techniques, use of certain relationships is made. A brief picture of some such guidelines is as under.

- Electromagnetic yoke

The field intensity is dependent on the thickness of the job and the distance between its poles. It decreases with the increase of the pole separation and thickness of the job.

- Prod magnetization

The field intensity is dependent upon the separation of prod tips and thickness of job. Prod spacing of up to 8 inch (200 mm) and a minimum of 3 inch (75 mm) is recommended.

– Coil magnetization

The field generated is longitudinal and the value of direct or rectified current is based on the ratio of length to diameter of the job. For non-cylindrical jobs, diameter value is the maximum cross-sectional diagonal. Depending upon the values of L/D, different relationships are used for calculating the value of magnetizing current.

— Head shot

The current is passed directly into the jobs, the resultant field is circular in nature. The value of current is dependent on the outside diameter of the job. The value of current is the same as for central conductor or threading bar.

9.2.7. Sequence of testing

The sequence of operation in magnetic particle testing applies to the relationship of timing and application of particles and magnetizing current. Two basic techniques apply, continuous and residual, both of which are commonly employed in industry today.

Wet continuous magnetization

The technique is applied for most applications utilizing either dry or wet particles. The sequence of operation for the 'wet' and 'dry' continuous magnetization techniques are significantly different. The 'wet' continuous magnetization technique generally applies to those parts processed on a horizontal wet bench type unit. In practice it involves bathing the part with the inspection medium and terminating the bath application simultaneously with the initiation of the current. Thus there is no application of inspection medium while the current is flowing. Typically there may be a slight overlap relative to cessation of bath application and flow of the magnetizing current.

Dry continuous magnetization

In this method, the initiation of the current is done prior to the application of the dry powder, and terminated after the application of the powder has been completed and excess powder blown off.

Residual magnetization

In this case the examination medium is applied after the magnetizing force has been discontinued. The method has some usefulness for retentive materials.

9.2.8. Demagnetization

All ferromagnetic materials will retain some residual magnetism, the strength of which is dependent on the retentivity of the part. Residual magnetism does not affect the mechanical properties of the part. However, a residual field may permit chips to adhere to the surface affecting subsequent machining operations, as well as painting or plating. Additionally, if the part will be used in locations near sensitive instruments, high residual fields could affect the operation of these instruments. Furthermore, a strong residual magnetic field in a part to be arc welded could interfere with this operation. Residual fields may also interfere with subsequent magnetic particle examination. Demagnetization is required only if specified in the drawings, specification or purchase order. When required, an acceptable level of residual magnetization and the measuring method shall also be specified.

The ease of demagnetization is dependent on the coercive force of the metal. In general, demagnetization is accomplished by subjecting the part to a field equal to or greater than that used to magnetize the part, then continuously reversing the field direction while gradually decreasing it to zero.

Effectiveness of demagnetization

It can be indicated by the use of appropriate magnetic field indicators or field strength meters. However, a part may retain a strong residual field after having been circularly magnetized and exhibit little or no external evidence of this field. Therefore, the circular magnetization should be conducted before longitudinal magnetization if complete demagnetization is required.

9.2.9. Post inspection cleaning

Post-test cleaning is necessary where magnetic particle materials could interfere with subsequent processing or with service requirements.

Typical post cleaning techniques employed are: (1) the use of compressed air to blow off unwanted dry magnetic particles; (2) drying of wet particles and subsequent removal by brushing or compressed air; and (3) removal of wet particles by flushing with solvent. Other suitable post-test cleaning techniques may be used if they will not interfere with subsequent requirements.

9.2.10. Acceptance standards

The acceptability of parts examined is not specified herein. Acceptance standards are a matter of agreement between the manufacturer and the purchaser and should be stated in a referenced specification or code.

9.2.11. Instructions for level-1 operator (weld inspection by yoke magnetization)

Description

The yoke method of magnetic particle examination is applied to detect cracks and other discontinuities that are only open to or near sub-surface of the ferromagnetic materials.

Applicable documents:

- Inspection standards ASME Section-V, Article-7 (magnetic particle examination) and SE-709 (standard practice for magnetic particle examination).
- Acceptance standard, ASME Section-VIII, Division 1.

Equipment and accessories

- AC/DC yokes.
- Dry magnetic powder.
- Wet inks, if wet inks are in prepared forms they shall have the following particle concentrations.
 - (a) Black ink: Particles 1.2 to 2.4 mL in 100 mL of bath.
 - (b) Fluorescent: Particles 0.1 to 0.5 mL in 100 mL of bath.
- Berthold field indicator.

- Powder blower.
- Calibrated gaussmeter.
- Black light source of ultraviolet radiations to be used in case if examination with fluorescent method is to be done. The source intensity of light shall be a minimum of 800 $\mu\text{watt}/\text{cm}^2$ on the surface of the part to be done.

Extent of examinations

All weld areas and adjacent areas within one inch on both sides of weld edge shall be examined.

Sequence of operation

Continuous magnetization technique shall be applied i.e. magnetizing current will be initiated prior to the application of dry powder and simultaneously with the application of wet inks.

Surface preparation

Prior to yoke magnetization the surface to be examined and all adjacent areas within one inch on both sides of weld edge shall be dry and free of all dirt, grease, lint, scale, welding flux, spatter and other extraneous materials that could interfere with the examination.

Examination medium

The ferromagnetic particles to be used as an inspection media shall be wet or dry and may be either fluorescent or non-fluorescent. Use of powder dispenser bulb for dry magnetic powder and aerosols for wet inks may be made. For maximum sensitivity to surface defects, use of wet ink may be preferred.

Magnetization of the test plate and inspection

Put the electromagnetic yoke (alternating current or direct current) on the test piece (welded plate) and place it along and then across the weld surface to detect cracks and other discontinuities oriented perpendicular or nearly perpendicular to the lines of magnetic flux. Apply the inspection medium while the current in the electromagnetic yoke is flowing. Keep the legs of yoke 6 inch (approx.) or so apart.

Magnetizing field adequacy

The field strength is determined by the lifting power of the yokes (4.5 kg and 18 kg weights for alternating and direct current respectively), however if necessary verify the adequacy of the magnetic field by placing the magnetic field indicator of the type (Berthold) on the magnetized area between the poles of the magnet. Formation of the clearly defined lines due to accumulation of the magnetic particles over the copper face of the indicator will be indication of the desired adequacy of the field.

Examination coverage

Examination shall be conducted in succession with sufficient overlap to cover 100% area at required sensitivity.

Inspection

Discontinuities on the surface are indicated by retention of the examination medium. The maximum sensitivity is for those lying transverse or nearly so to the magnetic field lines. Observe them and record.

Recording and reporting

Record the size, number and location of all linear and round indications (with size above 1.6 mm). Give in sketch form their size, location and frequency. For permanent recording make use of transparent adhesive backed tape. Report the test results on the standard report form along with a sketch showing the location, size, number and orientation of the observed discontinuities.

Post examination cleaning

Post examination cleaning is necessary where magnetic particle materials could interfere with subsequent processing or with service requirements. Dry the wet particles and remove by brushing or with compressed air. Removal of wet particles with solvent may be used if required.

Demagnetization

Perform demagnetization using AC-coil. Check the level of demagnetization, it should not exceed 3G (240 A/m) anywhere in the test part when checked with calibrated gaussmeter.

9.3. Standards

9.3.1. *Qualification and certification of personnel*

For NDT to be economically effective, it must locate defects quickly and accurately. The accuracy and speed at which an operator can perform a non-destructive inspection is based not only on his training and experience but also on the quantity and reliability of the test equipment. Manufacturers of aerospace and nuclear products spend considerable time and money to train and certify an inspector for each non-destructive testing method. His effectiveness is directly related to training, available equipment and working conditions.

To avoid unreliable results of an NDT examination, besides using standardized equipment and test methods, the person carrying out the examination must also be properly educated, trained and certified in the method. Various standards are available to cater for this requirement. Lately, there is being started an effort to harmonize the education, training and certification. Some of the standards of this type are:

- ISO/FDIS 9712-99: Non-destructive testing — qualification and certification of personnel.
- MIL-STD-410: Qualification of inspection personnel (magnetic particle and liquid penetrant).
- DIN 54160: Requirements for non destructive testing personnel.
- SNT-TC-IA: Recommended practice for non-destructive testing personnel, qualification and certification.
- IIS/IIW-589-79: Recommendation relating to the training of non-destructive testing personnel.
- ASTM E-543: Recommended practice for determining the qualifications of non-destructive testing agencies.

9.3.2. Internal specifications and corresponding standards

Materials or product producers frequently have their products non-destructively inspected on their own or at an independent NDT facility prior to being shipped to the prime contractor. MIL-STD-410 and SNT-TC-IA presently specifies the procedures by which an NDT facility can qualify its own personnel; However, to qualify independent or vendor NDT facilities, the prime contractor must survey and certify each one separately. Each prime contractor therefore must establish procedures for performing this task. The NDT facilities, on the other hand, must comply with all the different requirements specified in order to remain certified.

9.3.3. Codes and standards

Codes and specifications

Codes and specifications are similar types of standards that use the verbs "shall" or "will" to indicate the mandatory use of certain materials or actions or both. Codes differ from specifications in that their use is mandated with the force of law by governmental jurisdiction. The use of specifications becomes mandatory only when they are referenced by codes or contractual documents. A prime example of codes is the ASME boiler and pressure vessel code which is a set of standards that assures the safe design, construction and testing of boilers and pressure vessels.

Standards

Standards are documents that govern and guide the various activities occurring during the production of an industrial product. Standards describe the technical requirements for a material, process, product, system or service. They also indicate, as appropriate, the procedures, methods, equipment or tests to determine that the requirements have been met.

There are different NDT standards available for respective methods issued by different international standard-issuing organizations. Some of these organizations and their standards on magnetic particle testing are given below:

American National Standards Institute (ANSI)

- (a) ANSI/ASTMA 275 Magnetic particle examination of steel forgings.
- (b) ANSI/ASTMA 456 Magnetic particle inspection of crankshaft forging.
- (c) ANSI/ASTME 125 Reference photographs for magnetic particle indications of ferrous castings.
- (d) ANSI/ASTME 269 Definition of terms relating to magnetic particle inspection.

American Society for Testing and Materials (ASTM)

- (a) A275 Magnetic particle examination of steel forging.
- (b) A456 Magnetic particle inspection of large crankshaft forgings.
- (c) E125 Standard reference photographs for magnetic particle indications on ferrous castings.
- (d) E269 Definition of terms relating to magnetic particle inspection.

- (e) E709 Standard recommended practice for magnetic particle examination.
- (f) D56 Test methods for flash point by tag closed test.
- (g) D93 Test methods for flash point by Pensky Martens closed tester.
- (h) D96 Test methods for water and sediment in crude oils.
- (i) D445 Test methods for kinematic viscosity of transparent and opaque liquids and the calculation of dynamic viscosity.
- (j) D808 Test methods for chlorine in new and used petroleum products (bomb method).
- (k) D2393 Test methods for viscosity of epoxy resin and related components.

Department of Defence, USA (DOD)

- (a) MIL-STD-271, ACN-1 Non-destructive testing requirements for metals.
- (b) MIL-STD-1949 Magnetic particle inspection.
 - Part a) Magnetic inspection units.
 - Part b) Magnetic particle inspection unit, light weight.
 - Part c) Magnetic rubber, inspection process.

American Welding Engineers (AWS)

- (a) D1-1 Structural welding code.
- (b) D14-6 Welding of rotating elements of equipment.

Society of Automotive Engineers (SAE)

- (a) AMS 2300F Premium aircraft quality steel (cleanliness, magnetic particle inspection procedure (also MAM 2300).
- (b) AMS 2301G Aircraft quality steel cleanliness, magnetic particle inspection procedure.
- (c) AMS 2640J Magnetic particle inspection.
- (d) AMS 3040 Magnetic particle inspection, material dry method.
- (e) AMS 3041A Magnetic particles, wet method, oil vehicle.
- (f) AMS 3042 A Magnetic particles, wet method, dry powder.
- (g) AMS3043 A Magnetic particles, wet method, oil vehicle, aerosol canned.
- (h) AMS 3044 B Magnetic particles, fluorescent wet method, dry powder.
- (i) AMS 3045 B Magnetic particles, fluorescent wet method, oil vehicle ready to use.
- (j) AMS 3046 B Magnetic particles, fluorescent wet method, oil vehicle, aerosol packaged.
- (k) AMS 3061 Inspection vehicle.

British Standards Institution (BS)

- (a) BS 6072 Methods for magnetic particle flaw detection.
- (b) BS 3683 Glossary of terms used in non destructive testing 'Part-2' Magnetic flaw detection.

- (c) BS 4069 Magnetic flaw detection inks and powders.
- (d) BS 4489 Method for assessing black light used in non-destructive testing.
- (e) BS 5044 Contrast paint used in magnetic particle flaw detection.
- (f) BS M35 Method for magnetic particle flaw detection of materials and components.

Standards Association of Australia (SAA)

- (a) As 2085 Australian standard specification for magnetic particle testing media.
- (b) As 1171 Methods for magnetic particle testing of ferromagnetic products and components.

Japanese Institute of Standards (JIS)

- (a) JIS G 0565 Methods for magnetic particle testing of ferromagnetic materials and classification of magnetic particle indications.

American Petroleum Institute (API)

- (a) API-5A Specification for casing, tubing and drill pipe.
- (b) API-5AC Specification for restricted yield strength casing and tubing.
- (c) API-5AX Specification for high strength casing, tubing and drill pipe.
- (d) API-5L Specification for line pipe.
- (e) API-5LU Specification for ultra high-test heat treated line pipe.
- (f) API-RP 5A5 Recommended practice for the field inspection of new casing, tubing and plain end drill pipe.

American Society of Mechanical Engineers (ASME)

- (a) Section III: Rules for construction of nuclear power plant components.

This section provides requirements for the materials design, fabrication, examination, testing, inspection, installation, certification stamping and over pressure protection of nuclear power plant items such as vessels, concrete reactor vessels and concrete containments, storage tanks, piping systems, pumps valves, core support structures and component supports for use in or containment of, portion of the nuclear power system of any power plant. This section contains the following two divisions:

- Division 1;
 - Subsection NB - Class 1 components.
 - Subsection NC - Class 2 components.
 - Subsection ND - Class 3 components.
 - Subsection NE - Class MC components.
 - Subsection NG - Core support structure.
 - Appendices.
- Division 2 - Code for concrete reactor vessels and containments.

- b) Section V: Non-destructive examination

This section contains requirements and methods for non-destructive examination which are referenced and required by other code sections. This section also includes manufacturer's examination responsibilities, duties of authorized inspectors and requirements for qualification of

personnel, inspection and examination. Examination methods included in this section are intended to detect surface and internal discontinuities in material, welds and fabricated parts, and components. The relevant article and standard in this section are: Article-6 (magnetic particle examination), and SE-709 (standard practice for magnetic particle examination).

c) Section VIII: Pressure vessels

This section is divided into two divisions. Division 1 covers the minimum safety requirements applicable to the construction, design and fabrication of pressure vessels under either internal or external pressure for operation at pressure exceeding 15 psig and to vessels having inside diameters exceeding six inches. Pressure vessels made according to the rules of Division 2 require closer inspection of the required fabrication details, material inspection, welding procedure and welding and more non-destructive examination, as the safety factor used for these vessels is less than the safety factor used for vessels fabricated according to the rules of Division 1.

d) Section XI: Rules for in-service inspection of nuclear power plant components

This section provides rules and requirements for in-service inspection of class 1 components, 2 and 3 pressure retaining components and their supports and in-service testing of pumps, valves and components in light water cooled nuclear power plants. It categorizes the areas subject to inspection and defines responsibilities, provisions for accessibility, examination method and procedures, personnel qualifications, frequency of inspection, record keeping and reporting requirements, procedures for evaluation of inspection results and subsequent disposition of results of evaluation and their requirements.

10. PRESENTATION AND RECORDING OF RESULTS (MT)

10.1. Preparation of report on the testing

10.1.1. Procedure

After magnetic particle examination in accordance with established procedure is done, a written report is to be prepared. This report shall include at least the following information:

- (1) Area to be examined (entire part or specific area).
- (2) Type of magnetic particle material (dry or wet, visible or fluorescent).
- (3) Magnetic particle equipment.
- (4) Part surface preparation requirements.
- (5) Magnetizing process (continuous, true-continuous, residual).
- (6) Magnetizing current (alternating, half-wave, direct).
- (7) Means of establishing part magnetization (prods, yoke, cable wrap, etc.).
- (8) Direction of magnetic field (circular or longitudinal).
- (9) Magnetic field strength (ampere turns, field density, magnetizing force, and number and duration of application of magnetizing current).
- (10) Application of examination media.
- (11) Interpretation and evaluation of indications.
- (12) Type of records.
- (13) Demagnetizing techniques, if required, and
- (14) Post-examination cleaning, if required.

In addition to the above mentioned procedure parameters, the test report should include the following information:

- (a) Work location.
- (b) Description & identification of the component tested.
- (c) Date of test.
- (d) Stage of test (e.g. before heat treatment, before or after final machining).
- (e) Reference to the written test procedure and the technique sheet used.
- (f) Name of the company.
- (g) Name and signature of the person performing the tests.

10.2. Preparation and completion of the report form

The results of all magnetic particle test shall be recorded. Records shall be identified, filed and made available to the procuring agency on request. Records shall provide traceability to the specific test object or the lot inspected and shall identify the testing facility and the procedure used in the testing. Each inspection or production organization normally develop a standard tests results report form in which all the desired procedural information and results are given. The results on discontinuities are normally quoted for their location & size and a final comment on their acceptance/rejection against the quoted specification or standard. A typical test form is as attached Figure 10.1.

10.3.1. To locate the indications within the component

Location and identification with reference to the test piece

To record size, number and location of all linear and round indications, use of sketches is made to show location, direction and frequency of indications. For the inspection of welds, any indication whose major dimension is greater than 1/16 inch (1.6 mm) is considered to be relevant. The following indications are unacceptable as per ASME code, Section VIII, Division-1.

- (1) All linear relevant indications.
- (2) All round indications if their dimension exceeds 3/16 inch (4.8 mm).
- (3) 4 or more round indications in line if the distance between indications is less than 1/16 inch (1.6 mm).
- (4) 10 or more indications in any 6 sq. inch of surface, with the major dimension of this area not to exceed 6 inch (150 mm) with the area taken in the most unfavourable location relative to the indication.

In the above paragraph, the word linear refers to an indication whose major dimension is more than three times the width and where it is equal or less than three times the width it is called round indication.

Location of defects

The location of defects is determined by two co-ordinates L and W. L is the distance from certain reference mark of the weld. W is measured from weld centre line. The different sides of the weld are identified by letters A and B. The location of the defect is measured from the centre of the defect. The orientation of the defect is reported in relation to the weld. A defect is longitudinal if it is parallel to the weld and transverse if it is perpendicular to the weld as indicated in Figure 10.2.

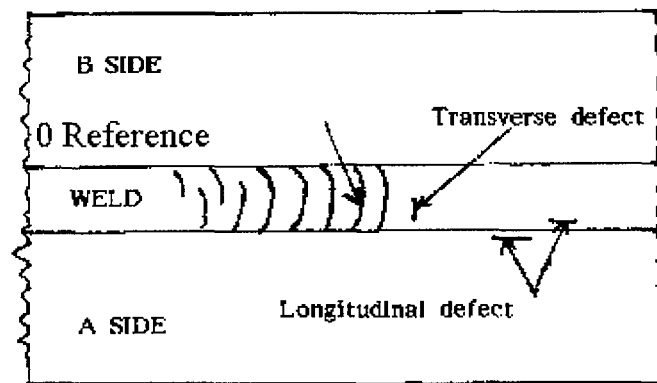

Figure 10.2: Location of defects in welded job.

10.3.2. Preservation of indications by photography

Photographic technique (non-fluorescent)

Direct photography makes excellent record of non-fluorescent powder pattern for future record and reference.

Photographic technique (fluorescent)

When photographing fluorescent indications, a K2 or G filter over the lens of the camera is essential to filter out black light. Test specimens require thorough cleaning of random fluorescent smears. Another requirement is a darkened room with two 100-watt black lights placed to bring out the brilliance of the fluorescent indications with as little reflective highlighting of the article as possible Figure 10.3. A light-coloured, non-fluorescent background is desirable so that the black outline of the article shows in silhouette.

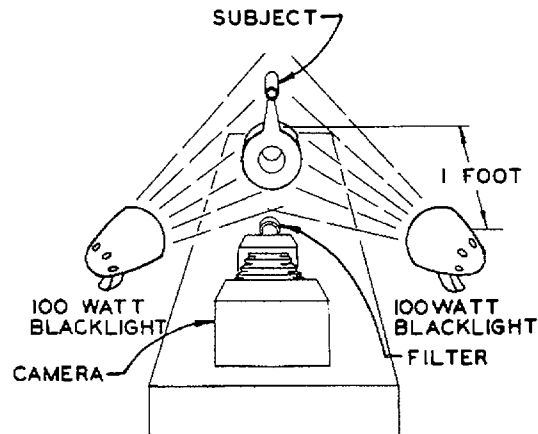

Figure 10.3: Photographing the fluorescent indications.

Panchromatic film exposure time

Exposure time varies greatly with the brilliance of the indications. With a G filter, exposures may vary widely depending on the brilliance of the indications. If the thinner K2 filter is used, the exposure time is cut about half but undesirable highlights from black light may come through stronger. A white light may be used to illuminate the background. The white light is to be placed so that the indication areas are not illuminated, either directly or by the highlight from the white light.

Negative quality

Since there is no scientific means for calculating black light exposure, a test negative is made for each set-up. The negative, after normal development, should show the indications in solid black with the article clearly defined. The negative should be checked especially for highlights interfering with, or resembling, the indications. Such highlights can often be moved, weakened or diffused, or eliminated by repositioning the lights.

Printing

Printing can be handled normally; usually using a medium grade paper. The objective is to get a very dark impression of the article as it is seen visually under black light, with clear white indications in the picture where fluorescent indications appear on the article.

10.3.3. Using transfer techniques

Lacquer transfer technique

If it is desired to retain the indication in place on the test specimen, a transparent lacquer is sprayed over the indication. Spraying or dipping is more effective than brushing because the latter, no matter how carefully done, tends to disturb and mar the pattern. Stock lacquers are thinned at least three-to-one before being used for this purpose. When the wet method has been used, the surface is allowed to dry before the lacquer is applied.

Lacquer mixtures

There is another method using lacquer that employs a coloured lacquer as a suspension for a ferromagnetic powder of a different colour. The lacquer-particle mixture is applied, the magnetic field is induced before the lacquer sets, and the pattern becomes permanently fixed after the lacquer dries. A white lacquer with black ferromagnetic powder in suspension gives a black pattern on a white background and can be applied on practically any surface, or the lacquer can be applied first, allowed to dry, and the ferromagnetic powder applied afterwards. The resultant patterns are then photographed.

Transparent tape transfer technique

Probably the most convenient and, by far, the most widely used method of preserving indications and patterns is the transparent tape method. If the dry magnetic particle method is used, excess powder is carefully blown away or otherwise removed. If the wet method is employed, sufficient time is allowed for the liquid vehicle to evaporate from the particles composing the indication. Then a strip of transparent tape is carefully laid over the indication and gently pressed down with the fingers or a rounded stick. When the tape is peeled off, it brings the indication with it. The strip is then laid on white paper for photographing, on tracing paper for blueprinting, or on a page of a permanent record book. With care, the transferred pattern remains well-defined and accurate in every detail, and may serve as well as the original pattern as a basis for judging and studying the indication.

10.3.4. Knowledge of documentation system

Permanent records of the appearance of indications can be of great value for a number of purposes. Records showing the typical appearance of acceptable or rejectable indications of discontinuities are useful for the guidance of inspectors in the testing of large number of similar parts. A record of indications of discontinuities which are subsequently investigated by sectioning or other means is an essential part of such report. Some times a part is put back into service containing a known discontinuity which experience has shown to grow slowly. Comparison of the indications obtained at next inspection with the records of the previous ones is a positive means for checking such growth rate. The documents supporting such inspection records should incorporate parameters such as:

(1) wet particle concentration; (2) dry particle bulk permeability; (3) dry particle visual contrast with inspected surface; (4) dry particle filler content; (5) verification of saturation for circular magnetism; (6) intensity of ultraviolet light at the test surface; (7) time intervals between ultraviolet intensity checks; (8) relation between field strength at the centre of a coil and the current through the coil; and (9) time intervals between magnetizing coil current calibration.

In case of magnetic particle testing the recording of indications is done by methods such as sketching, photography, use of cellulose transparent tape and fixing by lacquer spray.

10.3.5. Management and control of complete documentation

Users of non-destructive testing need to have the capability to call up easily the results of previous and other method inspection in order to better interpret NDT data and results. In addition, they must also be alert to the possible deterioration of such records under storage and to the accuracy and completeness of any reproductions (such as microfilms, for example) that have been made.

At present it is recognized that the rapid increase in the use of computerized inspection equipment makes it feasible to maintain NDT results as digital records on magnetic or optical media. The new capability to call up previous inspection data obtained in manufacture or in a previous maintenance inspection offers great promise for improvement in interpretation and reliability of inspection.

11. INTERPRETATION OF RESULTS, LIMITATIONS (MT)

11.1. Presentation of results

The indications developed due to magnetic leakage fields are interpreted first to be relevant or non-relevant. The final decision after having determined the indications to be a relevant discontinuity, is to assess whether it will have an effect on the intended role of the part. One must consider parameters such as cost, life, failure probability, and the tolerance of the material to this type of defect, as guidelines for making a judgement to tolerate, to rework or to scrap the part. For cases where working documents do not specify, it is of worth to discuss some considerations that will assist in the evaluation.

11.2. Threshold of detection

11.2.1. Evaluation of results according to the criteria of the procedure and specifications

The decision on evaluation, however, becomes very simple in the presence of applicable documents such as procedure and acceptance standards. Normally the indications are characterized as linear or round. Linear being those with lengths greater than three times width whereas round are those with lengths equal to or less than three times the width. The parts are thus automatically accepted or rejected on the basis of mere presence of a certain type of oblique discontinuity. Normally the criteria of acceptance/rejection is the length or size for linear, diameter for round and separation between them in different situations. There are usually given recommendations on the fate of jobs found with un-acceptable defects such as to be repaired/rechecked, cut out of complete welds or scrap in the extreme case for very critical parts.

11.2.2. Additional possibilities for making the results more conclusive

The absolute identification of a given discontinuity involves the use of supplemental tests and these tests often require the actual cutting up of a specimen, or otherwise probing into it to see what the discontinuity really is that lies at or below surface to produce the indication. This effort shall make results more conclusive and reliable. Many of these tests are simple and can be performed with a minimum amount of laboratory or testing equipment. Others require specialized equipment and experience involving the use of testing laboratories and methods of metallurgical investigation.

To wipe off the magnetic particles forming an indication is almost instinctive and some times the defect, if a surface crack, is quite readily seen, once the exact location has been revealed by the indication. A low power hand glass is a most convenient pocket tool to aid the eye in such a first check. If the surface is rough, or is covered with a light film of rust, polishing the area where the indication appeared with fine emery cloth usually renders the defect more visible for study.

Another simple check is to wipe off the indication and again apply the powder or liquid suspension of particles, to see whether the indication will be reproduced by the residual field in the specimen. Since the residual method is always less sensitive than the continuous, it is obvious that if the original indication was produced by the continuous method, the manner in which it reappears by the residual method gives at once some indication of its severity and extent.

Often times it is worth while, in order to confirm the indication, to demagnetize the part and repeat the test from the start to make sure that the indication really does come back in the same form as originally.

11.2.3. Relation of discontinuities to potential failure

Surface or sub-surface

Surface discontinuities are more significant than similar sub-surface discontinuities. Sub-surface defects pose more potential hazards as they near the surface.

Length

Length is a valid measure of discontinuity significance. However, in a highly-stressed area even a micro-discontinuity is a potential hazard.

Depth

Surface discontinuities become more potentially dangerous as their depth increases.

Distribution

Discontinuities grouped or strung together will act as a single large discontinuity and are more serious than the scattered variety.

Location

Discontinuities situated in areas of high stress are more of a hazard than those in sections of low stress. If a discontinuity is found in a keyway, fillet, flange, hole or similar area of stress concentration, rework or rejection of the part should be suggested. When the discontinuity is situated so that the applied loadings do not open or affect the discontinuity, the defect is less significant and can sometimes be tolerated.

Function of the part

If a discontinuity is found in a part subjected to repeated loadings, it will fail much in advance of a part required to do very little work; therefore the work role of the part is a necessary consideration when determining acceptance standards.

11.3. Interpretation of findings with reference to the manufacturing process

The procedural steps discussed so far will result in the presentation for analysis or interpretation of a magnetic particle pattern caused by a defect, flaw or discontinuity. This section will deal with interpretation of the discontinuity and comment on the effect of the flaw when the part is placed in service.

In non-destructive testing terms such as indication, defect, discontinuity and flaw are often wrongly interchanged. Formally, an indication is a response requiring an interpretation to determine its significance. In magnetic particle inspection, this could be any magnetically held magnetic particle pattern on the surface of a part being tested. A defect is a discontinuity whose size, shape, orientation or location makes it detrimental to the useful service of the part. A flaw is an imperfection in an item or material, which may not be harmful.

When viewing a magnetic particle indication it is necessary to know something of the part's history and intended use. This will simplify interpretation and may also assist in determining whether an indication is surface or sub-surface. The trained technician can assess from codes, standards or engineering guidelines whether the discontinuity or flaw is likely to be harmful to the part's intended service.

11.3.1. Discontinuity position

Surface indications

Discontinuities open to the surface usually produce sharp, distinct, tightly held indication patterns. This is especially true of very fine tight cracks, etc., which are difficult to see but are especially harmful.

Sub-surface indications

Discontinuities below the surface tend to produce less distinct indications. They have a more diffused or fuzzy pattern than surface indications.

11.3.2. Processing discontinuities

These discontinuities are related to occur during various manufacturing processes such as forming, extruding, rolling, machining, welding, heat treatment and plating etc.

11.3.3. Processing discontinuities and magnetic particle indications

Seams

Indications from a seam are usually straight, sharp and fine. They are often intermittent when the seam is partially sub-surface and may present very little indication.

Laps

Since in most cases a lap is not normal to the surface, the indications will be heavy and irregular due to the defect being present in the metal at an angle. If scale is included in the lap, small fern like indications will stem from the main indication.

Burst

Magnetic particle inspection is an effective method to inspect ferrous materials for surface or near surface bursts. They give indications similar to heat treatment cracks except that the lines are less jagged or broken. Another difference is that bursts will not be related to design features.

Machining tears

This type of discontinuity will be typified by short, irregular lines which show up at right angles to the direction of machining.

Heat treatment cracks

Heat treatment cracks form a distinct well defined thin sharp magnetic particle pattern, characteristically a group of short, jagged lines grouped together and quite often in a curved series.

Grinding cracks

Grinding cracks, characteristically form a fine shallow network. The defect root is very sharp and would provide a notch for the initiation of a fatigue failure. Because of their limited depth, grinding cracks will seldom provide a heavy build up of indicating medium. The orientation of the discontinuity will vary from the single line indication to groups with varying orientation.

11.3.4. Welding discontinuities and magnetic particle indications

Magnetic particle inspection is used extensively on welds particularly in irregular sections where the contour of the part or the configuration of the surface at the welded junction makes both radiography and ultrasound inapplicable. The following is a listing of the more prominent types of welding discontinuities.

Lack of penetration

Lack of penetration is, by its nature, the deepest of the weld defects and should be inspected for by using dry powder DC magnetizing current. The indication will be broad and fuzzy which is typical of a sub surface discontinuity. Magnetic particle inspection is a surface or near surface inspection and should not be regarded as capable of inspecting for this condition to a depth exceeding 6 mm.

Inclusions

Inclusions found in elements may be of any shape, and may be metallic or non-metallic (i.e. oxides, sulphides, slag). Elongated slag inclusions are usually found at the fusion zone, but isolated irregularly shaped inclusions may be found at any area in the weld. The magnetic particle (MP) testing method is confined to machine weldments where the discontinuities are surface or near surface and even then would in most cases provide an unpronounced indication, jagged and irregularly shaped.

Porosity

Gas pockets occurring in the weld metal appear as voids. Magnetic particle testing can locate only near surface pores.

Shrinkage cracks

An uneven cooling rate or contraction of the weld may result in sharp discontinuities called shrinkage cracks. These are common in welding and are adequately located by magnetic particle inspection.

Incomplete fusion

Failure of the weld metal to fuse to the base metal will cause the discontinuity known as lack of fusion. The indication that results is of weak pattern denoting either a surface or subsurface defect which follows the weld edge.

Cracks

Cracks in the weld metal, crater cracks and cracks in the heat affected zone are easily detected by magnetic particle inspection. Cracks may occur in any direction with respect to the axial direction of the weldment.

Other indications

Near surface conditions such as slag inclusions, gas pockets, and other voids may be detected if they are of the size and shape to create a sufficient disturbance of the magnetic lines of force.

11.3.5. Service discontinuities responding to magnetic particle testing

The defect types covered in this series are those which occur from the operational loadings and the environment to which the component may be subjected in operation.

Overload

The exposure of a part to loading much in excess of the design performance constitutes an overload. The potential damage, which will occur at notches or fillets, will, if incipient, be apparent as a sharp distinct indication and easily distinguishable by magnetic particle inspection.

Fatigue cracks

When a part is subjected to cyclic applications of stress, microscopic cracks develop in or adjacent to areas of stress concentration and will grow with repeated stress applications until fatigue cracks develop and component failure occurs. This would occur at oil holes, fillets, keyways, splines and threads, generally where design was faulty or the material has been damaged. Since fatigue cracks originate at a surface they are readily indicated in ferromagnetic materials by magnetic particle examination. They give a sharp clear pattern which is generally uniform and unbroken throughout its length.

Corrosion

The occurrence of corrosion is significant in that stress-raisers may develop from corrosion pits, plus the material structure may be weakened by reduction of the cross section. The indication which results during the magnetic particle examination should be analysed for two effects: the extent of surface damage and the possibility of further underlying defects.

Stress corrosion

Defect types vary from very shallow to very deep cracks, usually following the grain flow of the material. This defect type is most prevalent in nonmagnetic materials. However, when a ferromagnetic material is being inspected for stress corrosion, magnetic particle inspection can apply.

11.3.6. Non-relevant magnetic particle indications

Design features or material properties can lead to leakage fields which will result in real magnetic particle inspection (MPI) indications. These indications are termed non-relevant and the operator must have the ability to recognize these indications as being not significant.

Structural changes

A magnetized part with an abrupt change in section will have an increase in internal flux density at the change. When this flux leaves the material, external poles will be formed and can cause an indication. Because of its proximity to a change in section, and the different quality of the indication, it is usually possible to distinguish such an indication from a structural change. The most damaging feature of this type of non-relevant indication is that it might mask an actual defect.

Magnetic writing

When two ferromagnetic materials come in contact with one another and when one or both are magnetized, external poles will be formed at the points of contact, these will attract the

indicating medium and form an indication. The most common occurrence is when parts come into contact with each other during inspection. While magnetic writing usually presents vague diffused indications, under certain inspection circumstances it can be distinct and clear enough to look like a defect. If suspected a part may be easily checked for the magnetic writing effect by demagnetizing and re-inspecting.

Brazing

When the MPI method is used on ferromagnetic materials joined by brazing, the result will be a particle pattern outlining the joint. This indication is not related to harmful discontinuity, but to the flux fields encountering a nonmagnetic interface. Magnetic particle inspection is not feasible here and another inspection method would be required to investigate more fully.

Magnetically dissimilar materials

The inadvertent joining of hard steel to soft steel by welding will result in sharp change in permeability. The welded joint will act as a concentrated leakage field and a magnetic particle pattern will be formed which will be indicative of the serviceability of the welded joint.

Cold working

When metal is plastically deformed at a temperature below that of recrystallization, this cold working hardens the steel, with a consequent change in permeability. The difference in permeability between the affected area and the remainder of the part is quite often sufficient to provide an indication. The indication from cold working will re-appear under repeated magnetization and can thus be distinguished from the similar indications of magnetic writing.

Longitudinal magnetization

When a part is longitudinally magnetized using a coil or a magnetic yoke, poles are formed at the ends of the part and where the yoke arms contact the surface. The indicating medium will be attracted to and concentrate in these areas, forming an indication.

False indications

False indications are those in which the indication has no relation to the magnetic disturbances associated with the inspection method. The indications thus found are caused by poor inspection practices such as poor cleaning, poor drainage, or the entrapment of the medium by a coarse surface. These problems can be eliminated by proper inspection technique.

11.4. Applications of magnetic particle testing and other methods of testing for surface and subsurface flaws

11.4.1. Burst

NDT methods application and limitations

Ultrasonic testing method

- Normally used for the detection of internal bursts.
- Bursts are definite breaks in the material and resemble a crack, producing a very sharp reflection on the scope.

- Ultrasonic testing is capable of detecting varying degrees of burst, a condition not detectable by other NDT methods.
- Nicks, gouges, raised areas, tool tears, foreign material, or gas bubbles on the article may produce adverse ultrasonic test results.

Eddy current testing method

- Not normally used. Testing is restricted to wire, rod, and other articles under 1/4 inch (6.35 mm) diameter.

Magnetic particle testing method

- Usually used on wrought ferromagnetic material in which the burst is open to the surface or has been exposed to the surface.
- Results are limited to surface and near surface evaluation.

Liquid penetrant testing method

- Not normally used. When fluorescent penetrant is to be applied to an article previously dye penetrant tested, all traces of dye penetrant should first be removed by prolonged cleaning in applicable solvent.

Radiographic testing method

- Not normally used. Such variables as the direction of the burst, close interfaces, wrought material, discontinuity size, and material thickness restrict the capability of radiography.

11.4.2. Cold shuts

NDT methods application and limitations

Liquid penetrant testing method

- Normally used to evaluate surface cold shuts in both ferrous and non-ferrous materials.
- Indications appear as a smooth, regular continuous or intermittent line.
- Certain castings may have surfaces that are blind and from which removal of excess penetrant may be difficult.
- The geometric configuration (recesses, orifices, and flanges) of a casting may permit build-up of wet developer thereby masking any detection of a discontinuity.

Magnetic particle testing method

- Normally used for the evaluation of ferromagnetic materials.
- The metallurgical nature of 431 corrosion-resistant steel is such that, in some cases, magnetic particle testing indications are obtained which do not result from a crack or other harmful discontinuities. These indications arise from a duplex structure within the material, wherein one portion exhibits strong magnetic retentivity and the other does not.

Radiographic testing method

- Cold shuts are normally detectable by radiography while testing for other casting discontinuities.
- Cold shuts appear as a distinct dark line, or band, of variable length and width, and definite smooth outline.
- The casting configuration may have inaccessible areas that can only be tested by radiography.

Ultrasonic testing method

- Not recommended. Cast structure and article configuration do not, as a general rule, lend themselves to ultrasonic testing.

Eddy current testing method

- Not recommended. Article configuration and inherent variables restrict the use of this method.

11.4.3. Grinding cracks

NDT methods application and limitations

Liquid penetrant testing method

- Normally used on both ferrous and non-ferrous materials for the detection of grinding cracks.
- Liquid penetrant indication will appear as irregular, checked, or scattered pattern of fine lines.
- Grinding cracks are the most difficult discontinuity to indicate and require the longest penetration time.
- Articles that have been degreased may still have solvent entrapped in the discontinuity and should be allowed sufficient time for evaporation prior to the application of the penetrant.

Magnetic particle testing method

- Restricted to ferromagnetic materials.
- Grinding cracks generally occur at right angles to grinding direction, although in extreme cases a complete network of cracks may appear, in which case they may be parallel to the magnetic field.
- Magnetic sensitivity decreases as the size of grinding cracks decreases.

Eddy current testing method

- Not normally used for detection of grinding cracks. Eddy current equipment has the capability and can be developed for a specific non-ferrous application.

Ultrasonic testing method

- Not normally used for detection of grinding cracks. Other forms of NDT are more economical, faster, and better adapted to this type of discontinuity than ultrasonics.

Radiographic testing method

- Not recommended for detection of grinding cracks. Grinding cracks are too tight and small. Other NDT methods are more suitable for detection of grinding cracks.

11.4.4. Heat-affected zone cracking

NDT methods application and limitations

Magnetic particle testing method

- Normally used for ferromagnetic weldments.
- Prod burns are very detrimental, especially on highly heat-treated articles. Burns may contribute to structural failure of article.
- Demagnetization of highly heat-treated articles can be very difficult due to metallurgical structure.

Liquid penetrant testing method

- Normally used for non-ferrous weldments
- Material that has had its surface obliterated, blurred, or blended due to manufacturing processes should not be penetrant tested until the smeared surface has been removed.
- Liquid penetrant testing after the application of certain types of chemical film coatings may be invalid due to the covering or filling of the discontinuities.

Radiographic testing method

- Not normally used for the detection of heat-affected zone cracking. Discontinuity orientation and surface origin make other NDT methods more suitable.

Ultrasonic testing method

- Used where specialized applications have been developed.
- Rigid standards and procedures are required to develop valid tests.
- The configuration of the surface roughness (i.e. sharp versus rounded root radii and the slope condition) are major factors in deflecting the sound beam.

Eddy current testing method

- Although not normally used for the detection of heat-affected zone cracking, eddy current testing equipment has the capability of detecting non-ferrous surface discontinuities.

11.4.5. Laps and seams

NDT methods application and limitations

Liquid penetrant testing method

- Compatibility with both ferrous and non-ferrous materials makes fluorescent liquid penetrant the first choice.
- Liquid penetrant indications will be circumferential, slightly curved, intermittent or continuous indication. Laps and seams may occur individually or in clusters.
- Foreign material may not only interfere with the penetration of the penetrant into the discontinuity but may cause an accumulation of penetrant in a non-defective area.
- Surface of threads may be smeared due to rolling operation, thereby sealing off laps and seams.
- Fluorescent and dye penetrants are not compatible. Dye penetrants tend to kill the fluorescent qualities in fluorescent penetrants.

Magnetic particle testing method

- Magnetic particle indications of laps and seams generally appear the same as liquid penetrant indications.
- Non-relevant magnetic indications may result from threads.
- Questionable magnetic particle indications can be verified by liquid penetrant testing.

Eddy current testing method

- Not normally used for detecting laps and seams. Article configuration is the restricting factor.

Ultrasonic testing method

- Not recommended for detecting laps and seams. Thread configurations restrict ultrasonic capability.

Radiographic testing method

- Not recommended for detecting laps and seams. Size and orientation of discontinuities restricts the capability of radiographic testing.

11.4.6. Gas porosity

NDT methods application and limitations

Radiographic testing method

- Radiography is the most universally used NDT method for the detection of gas porosity in weldments.

- The radiographic image of a “round” porosity will appear as oval shaped spots with smooth edges, while “elongated” porosity will appear as oval shaped spots with the major axis sometimes several times longer than the minor axis.
- Foreign material such as loose scale, flux, or splatter will affect validity of test results.

Ultrasonic testing method

- Ultrasonic testing equipment is highly sensitive, capable of detecting microseparations. Established standards should be used if valid test results are to be obtained.
- Surface finish and grain size will affect the validity of the test results.

Eddy current testing method

- Normally confined to thin-wall welded pipe and tube.
- Penetration restricts testing to a depth of not more than one quarter inch.

Liquid penetrant testing method

- Normally confined to in-process control of ferrous and non-ferrous weldments.
- Liquid penetrant testing, like magnetic particle testing, is restricted to surface evaluation.
- Extreme caution must be exercised to prevent any cleaning material, magnetic (iron oxide), and liquid penetrant materials from becoming entrapped and contaminating the rewelding operation.

Magnetic particle testing method

- Not normally used to detect gas porosity. Only surface porosity would be evident. Near surface porosity would not be clearly defined since indications are neither strong nor pronounced.

11.5. Safety

The expendable materials used in magnetic particle tests consist of iron powders, mineral pigments, magnetic oxides, fluorescent organic pigments, petroleum distillate carriers, wetting agents, corrosion inhibitors and a variety of cleaning compounds and solvents. As a group they are not highly dangerous chemicals but they must be used with care.

In the course of operation, magnetic particle test materials can have direct, unsafe effects on human operators (typical exposure to chemical solvents) or they can affect the environment in ways that are potentially hazardous (oil vehicle spills, for example).

Chemical substances should not be allowed prolonged contact with the skin. Wetting agents and solvents extract natural oils from the skin, causing inflammation and irritation. These chemicals should not be allowed to enter the mouth or eyes. Almost any compound other than water can irritate the eyes and many materials react with the tissues of mouth, throat and stomach. Solvent vapours, spray mists and dusts must not be inhaled. Vapours can irritate breathing passages and many kinds of vapours react immediately with the human nervous system. The flammability of carrier vehicles and cleaning solvents must always be considered.

11.5.1. Implementations of industrial safety standards in facilities and equipment and in their operation

There are three important safety considerations for magnetic particle testing personnel: (1) the inherent risks of the test site; (2) the potential dangers from an interaction between the test system and the testing environment; and (3) the hazard possible from a magnetic particle testing system itself.

Magnetic particle tests are conducted in a variety of potentially dangerous sites: high on the superstructure of sky scrapers under construction, under water, and in tightly confined pressure vessels. The testing personnel must first be made aware of the environment's particular safety requirements and must learn to operate within the site's own safety limits.

Secondly, it must be recognized that magnetic particle test systems can react adversely with certain environmental conditions. Test systems using prods, for example, can be sources of electrical arcing. In the presence of explosive vapours or flammable gases, electrical hazards become doubly dangerous as the cause of ignition.

Finally, there are the safety considerations needed for the test system itself. Primary among these are (1) the cautions associated with the electrical and mechanical systems; and (2) the care needed when using petroleum distillates and other particle vehicles.

Use of material safety data sheet

In the past, it was often difficult to know the hazards involved in the use of a chemical product. If the product was highly flammable or toxic, a label was required to carry certain warnings. However, as product liability cases began to award large settlements to users injured by products carrying insufficient warnings, some suppliers began to provide relatively detailed hazard information about their products.

In November 1985, it became easier to assess the hazards of chemical products such as magnetic particle testing materials and to determine their safest use. At that time, a ruling by the Occupational Safety and Health Administration, OSHA Hazard Communication Rule (29 CFR 1910.1200), became compulsory and mandated the use of material safety data sheets (MSDS) for all chemicals that are hazardous or contain hazardous ingredients. The MSDS must be supplied to a customer with the initial shipment of any applicable chemical and must be updated whenever significant new information is discovered. Material safety data sheets must be available to the user of the product in the work area.

The format for the MSDS may be taken from the US Department of Labour's non-mandatory form or it may be a supplier's individualized form (alternate versions must meet OSHA requirements and must present all the required information).

The different sections of the (MSDS) form are as under:

Section I

Section I of the form identifies the product and the party responsible for the product. This section includes the product name as found on the container label and the name, address and telephone number of the manufacturer, importer or distributor (a responsible party able to provide additional information about the product).

Section II

Section II lists all the hazardous materials in the product as well as an indication of their breathing hazards. The permissible exposure limit mandated by OSHA (OSHA PEL) is the maximum concentration that any user is permitted to breathe during eight hours in twenty-four.

The American Conference of Governmental Industrial Hygienists is an advisory group that recommends the threshold limit value (ACGIH TLV). This is the concentration of a material that an individual can be exposed to without harm, eight hours a day, indefinitely. These concentrations are usually expressed as parts per million (ppm) in the air, by weight, or as milligrams per cubic metre of air.

Section III

Section III lists relevant physical properties such as volatility, vapour pressure, flammability, etc. of the product. These are important because they can aggravate or sometimes diminish the effects of the hazards, listed in Section II. The need for knowing them is very essential.

For instance, a volatile solvent (one having a low boiling point, high vapour pressure or high evaporation rate) is doubly hazardous because much of it will enter the breathing air during use. This may then require special ventilation or respiratory protection for users. Any solvent with a boiling point lower than water at 100°C (212°F) can be considered a low boiling point solvent.

The vapour density of a liquid is another important characteristic noted in Section III. Vapours with high density tend to sink, accumulate and spread. Users standing in the testing area may be unaware that a hazardous concentration of vapour exists at floor level. Most solvent vapours are denser than air and tend to settle. Chlorinated solvent vapours are much denser than air and their tendency to settle is pronounced.

Section IV

More detailed fire and exposure hazards are listed in MSDS Section IV.

Many magnetic particle testing materials are incombustible solids and many of the liquid vehicles are actually treated water. However, some combustible liquid vehicles are in common use. Flash point is the accepted means for measuring the fire hazard of these vehicles.

The safest oil vehicles have flash points over 90°C (200°F). The lower explosive limit (LEL) indicates the concentrations of vapour in air that are ignitable and potentially explosive. Concentrations below the LEL are too lean to be fire hazards. Above the LEL, are concentrations too rich to burn. The material safety data sheet must list recommended extinguishing media and special fire fighting procedures for hazardous or explosive materials.

Section V

Section V lists materials that may be dangerously reactive. The intent of this listing is to provide warnings about material compatibilities, as a guide for storage or use of the substances in mutual contact.

Section VI

Section VI specifies the types of exposure to guard against (route of entry) and the acute and chronic health conditions that can accompany the over exposure to hazardous materials.

A number of organizations are involved in testing chemical substances for carcinogenicity and chief among these organizations are the National Toxicology Programme (NTP) and the International Association for Research on Cancer (IARC), an affiliate of the World Health Organization. The Occupational Safety and Health Administration also publishes a list of carcinogens. If any of these groups consider a product or its ingredients carcinogenic, that fact must be noted on the MSDS.

Section VII & VIII

Earlier sections of the MSDS point out safety hazards and discuss how to deal with them when they arise. Sections VII and VIII discuss preventive measures — the means of avoiding hazards in the first place.

Handling and storage precautions are generally based on simple good house keeping. Flammable, combustible or pressurized products should not be stored near heat sources.

Chemical substances that are usually hard to ignite can burn vigorously if exposed to high temperatures such as those in a hot fire. Careless exposures should be avoided. Breathing dusts, vapours or spray mists, leaving them on the skin, or using the products around open flames are all basic but vitally important considerations.

Section VIII provides detailed instructions on avoiding hazards during the normal use of the specific chemical substances. This is the most difficult section of the MSDS to prepare because the supplier usually is not familiar with the testing environment or the level of exposure at each testing site. The organization that buys the material and receives the MSDS must add its own knowledge of in-house procedures to provide successful safety control measures.

Electrical equipment safety

Magnetic particle tests are performed in different environments with different electrical and mechanical safety considerations. In the controlled conditions of a testing facility, relatively simple operating and safety procedures may be adopted. For sites where explosive gases are always below a prescribed minimum concentration the electrical safety procedures can be much like those for a controlled testing facility. But in test environment where explosive gas concentrations are known to be high, stringent safety procedures are adopted.

In refineries and chemical plants, there is often the danger of explosion caused by electrical components. In the case of off shore oil rigs, magnetic particle testing is performed underwater and special attention may be paid to the design and operation of the magnetizing circuits.

Before designing equipment that might be subject to any form of electrical hazard, consult relevant codes. Using the creation of sparks as an example, several techniques have been developed for safe use of electrical equipment in potentially explosive atmospheres. The philosophy of such design first presents a basic choice: (1) completely eliminate the possibility of sparking; or (2) permit sparking but control the environment so that an explosion cannot occur.

Safety conditions required for the use of UV light

When an operator is making use of black light source for inspection purposes, he should be sure of the following:

- The filter glass is in place and is not cracked or damaged such that white light is emitted.
- After prolonged running of the lamp, its housing gets very hot and can cause burning. Do not touch this lamp housing with unprotected flesh.

- Do not, under any circumstances, shine the ultraviolet light onto eyes.
- Direct viewing of the lamp may, with certain people, cause an irritation of the eyes known as "fluorescence of the retina". This is a temporary condition and can be overcome by wearing sodium glasses.

11.5.2. Hazards of using toxic and inflammable materials

Hazardous materials are those that are toxic, corrosive, combustible or otherwise potentially hazardous to personnel or property, or which involve liquid or solid residuals that cannot be disposed of without prior treatment for compatibility to Federal, state or local environmental requirements, or as otherwise defined as hazardous by the specified documents. Equipment using hazardous materials should be classified as a hazardous installation.

Prior consultation with the buyer, including disclosure of complete engineering details of the hazardous materials, assigned hazardous installation classification, and other pertinent details must be provided.

The system should comply with the applicable requirements of the assigned hazardous installation classification. Prior to shipment, the manufacturer must obtain validated approval of the Factory Mutual Engineering Division, certifying design compliance with such requirements.

There are few unusual fire hazards associated with the magnetic particle testing media. Oil based wet method vehicles are hard to ignite at room temperature but can catch fire if sprayed or atomized near ignition sources such as high energy arcs or red hot surfaces. As a mist in air, the concentration of oil droplets may be high enough to sustain combustion in the same way that a dust such as flour may explode if a hot ignition source is present. Aerosol cans heated above 55°C (130°F) can burst and add their contents to an existing fire. Even dry magnetic powders can burn if finely distributed over a red hot surface. They do not burn with the vigour of an oil spray but an alarming and dangerous shower of sparks often occurs. In addition, some chlorinated solvents break down under heat, producing very toxic substances such as carbon monoxide and phosgene gases.

11.5.3. Materials, equipment and accessories for the protection of persons and facilities

General housekeeping

Good housekeeping is essential to avoid accidents. A good housekeeping means that every one knows his duties as well as the safety devices available with the factory. Following points have considerations:

- Good working layout.
- Emergency escape routes.
- Proper storage/handling facilities.

Protection

- Either a mobile fume extraction fan unit, or breathing apparatus should be used by the operator.
- To conclude, hazards of fumes and dusts can be minimized by improving general ventilation of the place where magnetic particle testing is carried out.

- Using local exhaust units.
- Wearing individual respiratory protective equipment.
- Use gloves to protect hands.
- Wear safety boots to protect the feet if the work is to be carried out at site.
- Use helmet to protect head injury while working at site.
- Observe all other site safety precautions while working at site.

BIBLIOGRAPHY

MCKELVEY, E.W., Level-3 Study Guide for Liquid Penetrant Method, American Society for Non-destructive Testing (1980).

McMASTER, R.C., Non-destructive Testing Handbook, 2nd Edition, Liquid Penetrant Test, American Society for Non-destructive Testing (1989).

GENERAL DYNAMICS, Non-destructive Testing, Liquid Penetrant Testing: Classroom Training Handbook, 4th Edition, American Society for Non-destructive Testing(1977).

MCKELVEY, E.W., Study Guide for Magnetic Particle Method, American Society for Non-destructive Testing (1980).

ABEL ETAL, L.A., Non-destructive Evaluation and Quality Control Handbook, 9th Edition, ASM International (1989).

SCHMIDT, J.T., Non-destructive Testing Handbook 2nd Edition, American Society for Non-destructive Testing (1989).

GENERAL DYNAMICS, Non-destructive Testing, Magnetic Particle Testing: Classroom Training Handbook, 4th Edition, American Society for Non-destructive Testing (1977).

AMERICAN SOCIETY FOR NON-DESTRUCTIVE TESTING, NDT-Specifications and Standards Commonly Used: Listing of Issuing Organization, ASNT (1988).

AMERICAN SOCIETY FOR MECHANICAL ENGINEERS, Boiler & Pressure Vessel Code Section V, ASME (1995).

BETZ, C.E., Principles of Magnetic Particle Testing, Magnaflux Corporation, American Society for Non-destructive Testing (1988).

BERGER, H., Non-destruction Testing Standards, American Society for Testing Materials (1977).

BOLTAN, W., Electrical & Magnetic Properties of Materials, Longman Scientific & Technical Group, UK (1992).

CANADIAN GENERAL STANDARDS BOARD, Manual on Magnetic Particles Inspection, Ministry of Supply and Services No. 48-GP-11M, Ottawa, Canada, KIA 1G6 (1981).

CANADIAN GOVERNMENT SPECIFICATION BOARD, Manual on Liquid Penetrant Inspection, Ministry of Supply and Services No. 48-GP-12M, HU, Quebec. KIA 0S5 (1977).

MOORE, H.D., Materials and Processes for NDT Technology, American Society for Non-destructive Testing (1981).

DIETER, G.E., Mechanical Metallurgy 2nd Edition, McGraw-Hill (1976).

KRAR, S.F., OSWALT J.W, AMAND J.E.S.T., Technology of Machine Tools, 2nd Edition, McGraw-Hill Ryerson Limited, Canada (1976).

LINNERT, G.E., Welding Metallurgy, 3rd Edition, American Welding Society (1965).

WENK S.A., Choosing NDT: Benefits of NDT in your Quality Assurance Programme, American Society for Non-destructive Testing (1987).

YOUNG J.G., NDT Aspects of the Significance of Weld Defects: The Proceeding of a SANDT, Seminar, School of Applied Non-destructive Testing, Cambridge (1988).

INTERNATIONAL ATOMIC ENERGY AGENCY, Non-destructive Testing: A Guidebook for Industrial Management and Quality Control Personnel, Training Course Series No. 9, IAEA, Vienna.

INTERNATIONAL ATOMIC ENERGY AGENCY, International Basic Safety Standards for Protection Against Ionizing Radiation and for the Safety of Radiation Sources, Safety Series No. 115, IAEA, Vienna (1996).

RELATED IAEA PUBLICATIONS

Training Guidelines in Non-Destructive Testing Techniques, IAEA-TECDOC-407 (1987).

Ultrasonic Testing of Materials at Level-2: Training Manual for Non-destructive Testing Techniques, IAEA-TECDOC-462 (1988).

Training Guidelines in Non-Destructive Testing Techniques, 1991 Edition, IAEA-TECDOC-628 (1991).

Industrial Radiography: Manual for the Syllabi Contained in IAEA-TECDOC-628, Training Course Series No. 3 (1992).

Non-Destructive Testing: A Guidebook for Industrial Management and Quality Control Personnel, Training Course Series No. 9 (1999).

Ultrasonic Testing of Materials at Level 2: Manual for the Syllabi contained in IAEA-TECDOC-628, Training Course Series No. 10 (1999).

CONTRIBUTORS TO DRAFTING AND REVIEW

Afzal, M.	Pakistan Atomic Energy Commission, Pakistan
Arif, Ali	Pakistan Atomic Energy Commission, Pakistan
Awan, A.M.	Pakistan Atomic Energy Commission, Pakistan
Berg, H.W.	BERG GmbH, Germany
Dobrowolski, M.	International Atomic Energy Agency
Harding, N.G.	Namron & Associates Inc., Canada
Jamaludin	Pakistan Atomic Energy Commission, Pakistan
Khan, A.A.	International Atomic Energy Agency
Kulkarni, P.G.	Bhabha Atomic Research Centre, India
Rodriguez, J.A.	TECNATOM, S.A., Spain
Shabbir, A.	Pakistan Atomic Energy Commission, Pakistan
Vladu, M.L.	F.E.C.N.E. - S.A., Romania
Zaheer, A.	Pakistan Atomic Energy Commission, Pakistan

